

# Adjustments

## ⚠ Warning!

Before riding, always make sure that the basic settings made by Öhlins are according to recommended Set-up Data. Read about adjustments and setting up in the Öhlins Owner's Manual before you make any adjustments. Contact an Öhlins dealer if you have any questions about setting up the shock absorber.

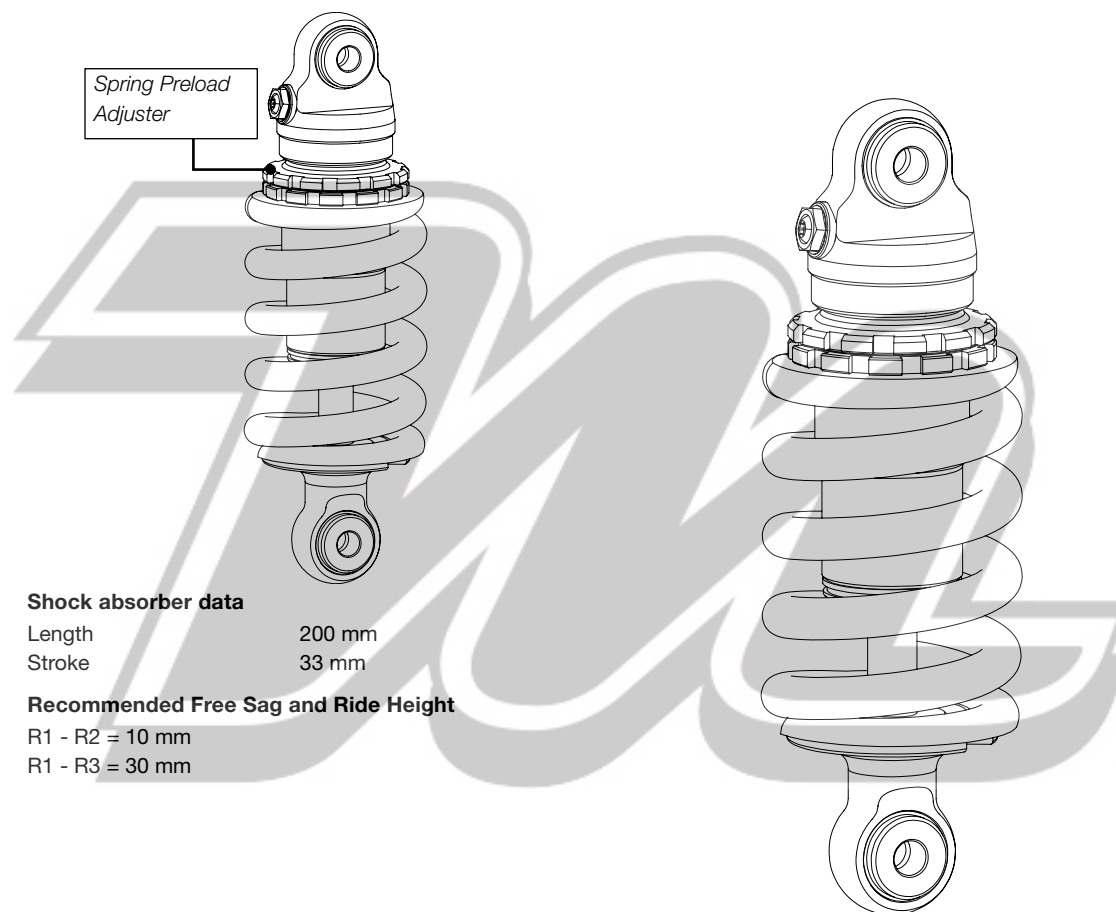

# Set-up Data

## Recommended set-up

|                     |          |
|---------------------|----------|
| Spring Preload      | 4 mm     |
| <b>Spring</b>       |          |
| Part No.            | Rate     |
| 00181-08            | 300 N/mm |
| Spring, free length | 110 mm   |

## Shock absorber data

|        |        |
|--------|--------|
| Length | 200 mm |
| Stroke | 33 mm  |

## Recommended Free Sag and Ride Height

|           |       |
|-----------|-------|
| R1 - R2 = | 10 mm |
| R1 - R3 = | 30 mm |

Before installing this product, check the contents of the kit. If anything is missing, please contact an Öhlins dealer.

## Kit Contents

|                 | Part No. | Pcs. |
|-----------------|----------|------|
| Shock absorber  | YA 941   | 1    |
| Öhlins Sticker  | 00192-01 | 2    |
| C-spanner, twin | 00710-01 | 1    |
| Owner's Manual  | 07241-02 | 1    |

Please note that during storage and transportation, especially at high ambient temperature, some of the oil and grease used for assembling may leak and stain the packaging. This is in no way detrimental to the product, wipe off the excessive oil/grease with a cloth.

## ⚠ Warning!

Before installing this product, read the Öhlins Owner's Manual. The shock absorber is an important part of your vehicle and will affect the stability.

Öhlins products are subject to continuous improvement and development, therefore, although these instructions include the most up-to-date information available at the time of printing, minor updates may occur.

To find the latest information contact your Öhlins distributor. Please consult your Öhlins dealer if you have any questions regarding the contents in this document.

Part no. YA941\_0  
Issued 2009-11-17



# Shock Absorber for Yamaha LC4V Crypton X YA 941

## Mounting Instructions

© Öhlins Racing AB. All rights reserved. Any reprinting or unauthorized use without the written permission of Öhlins Racing AB is prohibited.

Öhlins Racing AB  
Box 722  
S-194 27 Upplands Väsby, Sweden  
Phone +46 8 590 025 00  
fax +46 8 590 025 80



[www.ohlins.com](http://www.ohlins.com)



**⚠ Warning!**

*It is advisable to have an Öhlins dealer install the shock absorber.*

*When installing, consult your Vehicle Service Manual.*

- 1**  
Open the seat.
- 2**  
Remove the plastic cover in front of the seat.
- 3**  
Remove the plastic cover under the seat.
- 4**  
Remove the side covers, start with the small centre section above the tail light.
- 5**  
Remove the original shock absorber by removing the lower and upper mounting bolts.

**👁 Note!**

*Before installing the Öhlins shock absorber clean the vehicle thoroughly.*

- 6**  
Install the Öhlins Shock absorber in reverse order with the gas valve and spring adjustment nuts at the top.

**👁 Note!**

*Lower the motorcycle so that the shock absorber is slightly compressed, before tightening the screws.*

- 8**  
Make sure that all removed parts are reinstalled in the same way as they were before the installation of the Öhlins Shock Absorber.

**👁 Caution!**

*Make sure that all screws are tightened to the correct torque and that nothing fouls or restricts movement of the shock absorber when the suspension is fully compressed or extended.*

