

ADJUSTMENTS

Always ensure that the basic settings made by Öhlins are intact.

1 Spring Preload

Use the C-spanner provided in this kit. Turn the spring platform nut (A) clockwise to increase the spring preload, turn counter clockwise to decrease it. Lock the setting with the lock nut (B).

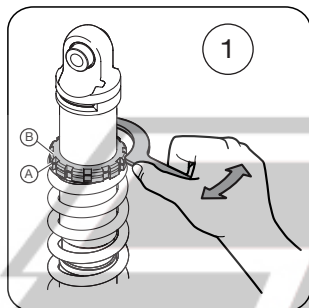

2 Rebound

Turn the wheel on the piston shaft above the end eye/bracket. Turn clockwise to increase damping, turn counter clockwise to decrease.

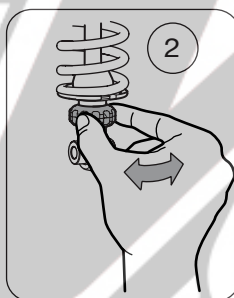

NOTE!

When delivered the Öhlins shock absorber is dialed to the recommended settings for the specific vehicle model. If you have changed the setting, reset according to the following:

The adjuster has a right hand thread. Turn the adjuster clockwise to fully closed (pos. zero [0]). Turn counter clockwise to open and count the clicks until you reach the recommended number (see Set-up Data).

CAUTION!

Do not use force, delicate sealing surfaces can be damaged. Handtighten only.

3 Length

We recommend you to adjust the length before installing the shock absorber to the vehicle. Use two wrenches.

Hold the upper nut with one hand and at the same time loosen the lock nut (lower nut). Turn the end eye/ bracket to the desired length. Lock the lock nut.

Tightening torque: 40 Nm

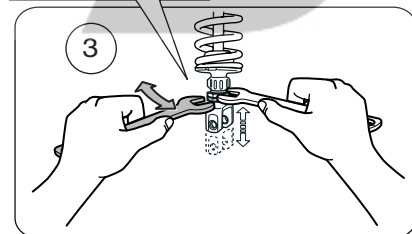
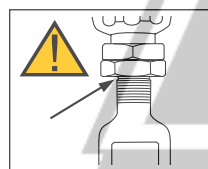

WARNING!

The adjustable end eye/bracket must not be threaded out more than that the groove is fully visible beneath the lock nut. This is maximum length. After adjusting, make sure that the lock nut is tightened.

Mounting Instructions

WITH SET-UP DATA

SHOCK ABSORBER YA746 for Yamaha XVS 1100 Drag Star

Before installing this shock absorber, check the contents of the kit listed below. If anything is missing, please contact your nearest Öhlins dealer.

Kit Contents:

	Part no.	Pcs.
Shock absorber	YA746	1
C-spanner	00710-02	1
Öhlins Sticker black	00191-13	2
Öhlins Sticker white	00191-20	2
Memo Notes Sticker	01180-01	1
Owner's Manual	07241-02	1

During storage and transportation, especially at high ambient temperature, some of the oil and grease used for assembling may leak and stain the packaging. This is in no way detrimental to the product, wipe off the excessive oil/grease with a cloth.



Set-up Data

Spring preload	18 mm
Rebound damping	14 clicks

Shock absorber length	299,5 ⁰ ₋₁₂ mm
Stroke	42,5 mm
Spring	21014-49
Free spring length	140 ⁺⁰ ₋₃

Before installing this product, read the Öhlins Owner's Manual!



HOW TO INSTALL

⚠ WARNING!

It is advisable to have an Öhlins dealer install the shock absorber.

1

Put the motorcycle on a workstand so that the rear wheel barely touches the ground.

⚠ WARNING!

Make sure the vehicle is securely supported so that it will not tip.

2

Remove the seat.

3

Remove the CDI box (A) and detach the socket (B). Remove the rivets and the cover (C).

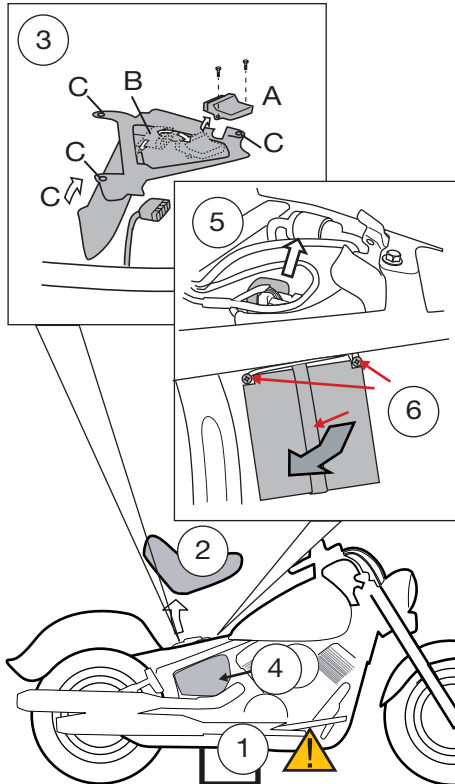

4

Remove both side covers.

5

Remove the starter solenoid from the battery box.

6

Disconnect the battery and remove it by detaching the rubber strap. Detach the battery box from the frame, without removing it.

7

Remove the engine cover from the left side of the vehicle.

8

Without detaching its hoses, gently lift the fuel filter from its fixing points.

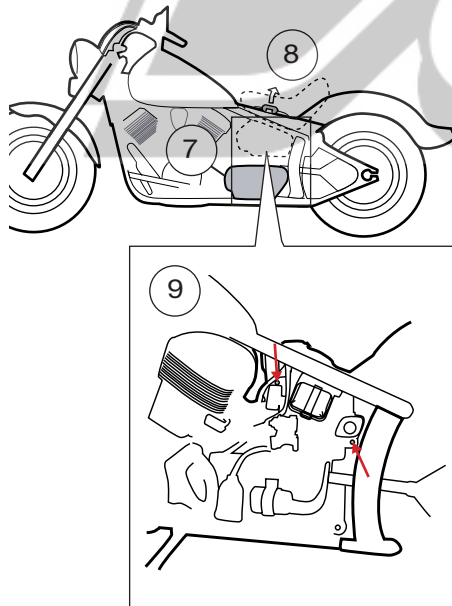

9

Remove the two screws indicated in the figure above so that the lid can be slightly folded out from the frame.

10

Loosen the screws on the triangle link and push rods. Remove them in the given order in the figure.

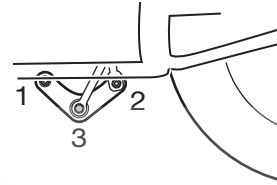

11

Gently fold out the lid on the left side so that the upper screw of the original shock absorber can be loosened. To remove the screw, gently fold out the battery box on the right side.

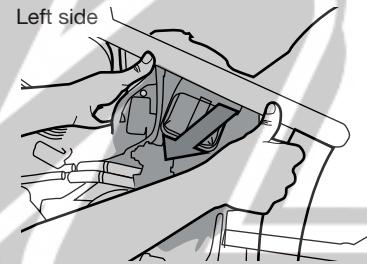

12

Remove the original shock absorber.

NOTE!

Recommendation! Before installing the Öhlins shock absorber:

- clean the vehicle thoroughly
- adjust the length of the shock absorber (check the headlight angle after adjusting the length!)

13

Install the Öhlins shock absorber from underneath the vehicle. Make sure the oil filling screw on the shock absorber is pointing to the rear.

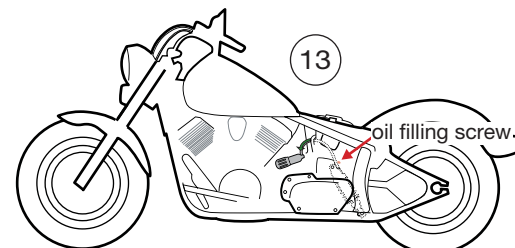

14

Attach the upper screw of the Öhlins shock absorber, reinstall the triangle link and push rods, without tightening yet.

NOTE!

Lower the motorcycle so that the shock absorber is slightly compressed, before tightening the screws.

15

Tighten the screws of the upper and lower attachments, triangle link and push rods.

16

Reattach the lid and the fuel filter (See step 8-9). Reattach the engine cover.

17

Reattach the left side cover.

19

(Right side) Reattach the starter solenoid to the battery box and attach the unit to the vehicle. Reconnect the battery and the right side cover.

20

Reinstall the cover. Reconnect the CDI box and attach it with the screws.

21

Reattach the seat. Make sure that all removed parts are installed in the same way as they were before the installation.

Make sure that all screws are tightened to the correct torque and that nothing fouls or restricts movement of the shock absorber when the suspension is fully compressed or extended.