

ADJUSTMENTS

Always ensure that the basic settings made by Öhlins are intact.

1 Spring Preload

Use the C-spanner provided in this kit. Turn the spring platform nut (A) clockwise to increase the spring preload, turn counter clockwise to decrease it. Lock the setting with the lock nut (B).

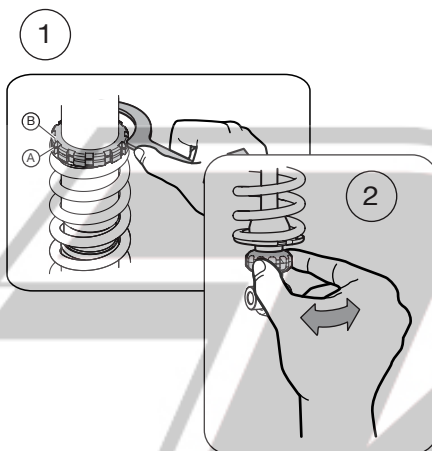

2 Rebound

Turn the wheel on the piston shaft above the end eye/bracket. Turn clockwise to increase damping, turn counter clockwise to decrease.

NOTE!

When delivered the Öhlins shock absorber is dialed to the recommended settings for the specific vehicle model. If you have changed the setting, reset according to the following:

The adjuster has a right hand thread. Turn the adjuster clockwise to fully closed (pos. zero [0]). Turn counter clockwise to open and count the clicks until you reach the recommended number (see Set-up Data).

CAUTION!

Do not use force, delicate sealing surfaces can be damaged. Handtighten only.

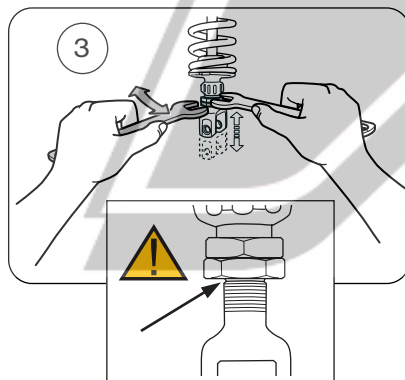

⚠ WARNING!

The adjustable end eye/bracket must not be threaded out more than that the groove is fully visible beneath the lock nut. This is maximum length. After adjusting, make sure that the lock nut is tightened.

3 Length

We recommend you to adjust the length before installing the shock absorber to the vehicle. Use two wrenches. Hold the upper nut with one hand and at the same time loosen the lock nut (lower nut). Turn the end eye/ bracket to the desired length. Lock the lock nut. Tightening torque: 40 Nm

Mounting Instructions

WITH SET-UP DATA

SHOCK ABSORBER YA717 for Yamaha XV 1900 Midnight Star

Before installing this shock absorber, check the contents of the kit listed below. If anything is missing, please contact your nearest Öhlins dealer.

Kit Contents:

	Part no.	Pcs.
Shock absorber	YA717	1
C-spanner	00710-02	1
Öhlins Sticker black	00191-13	2
Öhlins Sticker white	00191-20	2
Memo Notes Sticker	01180-01	1
Owner's Manual	07241-02	1

During storage and transportation, especially at high ambient temperature, some of the oil and grease used for assembling may leak and stain the packaging. This is in no way detrimental to the product, wipe off the excessive oil/grease with a cloth.

Set-up Data

Spring preload	13 mm
Rebound damping	14 clicks

Shock absorber length	311,5 \pm 0,2 mm
Stroke	42,5 mm

Spring	21115-69
Free spring length	150 \pm 0,3 mm

Before installing this product, read the Öhlins Owner's Manual!



HOW TO INSTALL

⚠ WARNING!

It is advisable to have an Öhlins dealer install the shock absorber.

1

Put the motorcycle on a workstand so that the rear wheel barely touches the ground.

⚠ WARNING!

Make sure the vehicle is securely supported so that it will not tip.

2

Loosen the screws on the exhaust system as indicated with the red arrows in the figure.

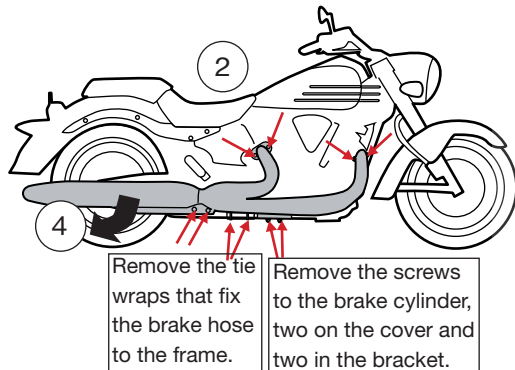

3

On the left side of the vehicle, loosen the engine fixing screw, without removing it.

4

Remove the front attachment of the original shock absorber by loosening the nut. Gently fold out the exhaust system and pull out the screw from the right side. Finally, push the collar from the left side, so that the front attachment can be removed.

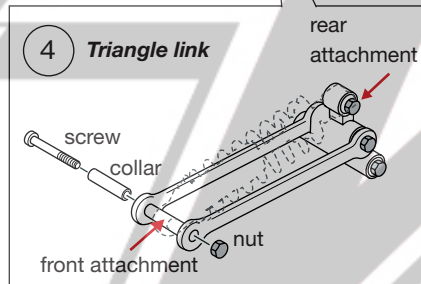
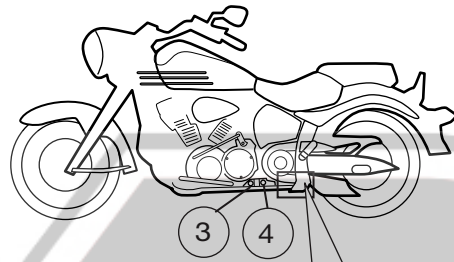

5

At this point, we recommend you to remove the rear wheel. Consult your vehicle service manual for correct procedure.

6

Remove the rear attachment of the original shock absorber. Remove the original shock absorber downwards.

NOTE!

Recommendation! Before installing the Öhlins shock absorber:

- clean the vehicle thoroughly
- adjust the length of the shock absorber (check the headlight angle after adjusting the length!)

7

Install the Öhlins shock absorber.

8

Fasten the front and the rear attachments and the pull rods, but do not tighten yet.

9

Reinstall the rear wheel.

NOTE!

Lower the motorcycle so that the shock absorber is slightly compressed, before tightening the screws.

10

Tighten the screws of the front and rear attachment and the triangle link.

11

Attach the exhaust system, the brake cylinder and the brake hose. Make sure that all removed parts are installed in the same way as they were before the installation.

NOTE!

Make sure that all screws are tightened to the correct torque and that nothing fouls or restricts movement of the shock absorber when the suspension is being fully compressed or extended.