

ADJUSTMENTS

Always ensure that the basic settings made by Öhlins are intact.

1 Spring Preload

Turn the knob on the hydraulic preload adjuster to set the spring preload. Turn clockwise to increase the preload, turn counter clockwise to decrease it.

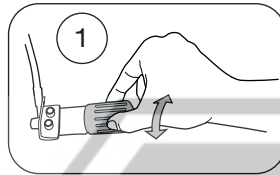

2 Rebound

Turn the wheel on the piston shaft above the end eye/bracket. Turn clockwise to increase damping, turn counter clockwise to decrease.

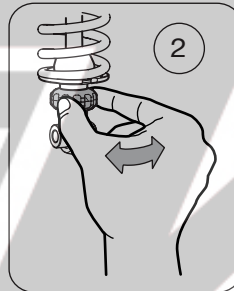

NOTE!

When delivered the Öhlins shock absorber is dialed to the recommended settings for the specific vehicle model. If you have changed the setting, reset according to the following:

The adjuster has a right hand thread. Turn the adjuster clockwise to fully closed (pos. zero [0]). Turn counter clockwise to open and count the clicks until you reach the recommended number (see Set-up Data).

CAUTION!

Do not use force, delicate sealing surfaces can be damaged. Handtighten only.

3 Length

We recommend you to adjust the length before installing the shock absorber to the vehicle. Use two wrenches. Hold the upper nut with one hand and at the same time loosen the lock nut (lower nut). Turn the end eye/ bracket to the desired length. Lock the lock nut.

Tightening torque: 40 Nm

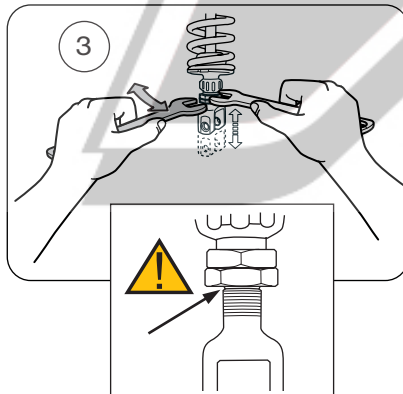

⚠ WARNING!

The adjustable end eye/bracket must not be threaded out more than that the groove is fully visible beneath the lock nut. This is maximum length. After adjusting, make sure that the lock nut is tightened.

Mounting Instructions

WITH SET-UP DATA

SHOCK ABSORBER YA709
for Yamaha XVS650A DragStar Classic

Before installing this shock absorber, check the contents of the kit listed below. If anything is missing, please contact your nearest Öhlins dealer.

Kit Contents:

	Part no.	Pcs.
Shock absorber	YA709	1
Bracket	20030-01	1
Spacer	20047-01	1
Screw K6S M6x12	05404-01	2
Screw K6S M6x40	05404-08	1
Öhlins Sticker black	00191-13	2
Öhlins Sticker white	00191-20	2
Memo Notes Sticker	01180-01	1
Owner's Manual	07241-02	1

During storage and transportation, especially at high ambient temperature, some of the oil and grease used for assembling may leak and stain the packaging. This is in no way detrimental to the product, wipe off the excessive oil/grease with a cloth.

Set-up Data

Spring preload	10 mm	Shock absorber length	276,5 $^{+0}_{-12}$ mm
Rebound damping	16 clicks	Stroke	34,5 mm
		Spring	21012-54
		Free spring length	120 $^{+0}_{-3}$ mm

Before installing this product, read the Öhlins Owner's Manual!



HOW TO INSTALL

⚠ WARNING!

It is advisable to have an Öhlins dealer install the shock absorber.

1

Put the motorcycle on a workstand so that the rear wheel barely touches the ground.

⚠ WARNING!

Make sure the vehicle is securely supported so that it will not tip.

2

Remove the seats. Consult your vehicle service manual.

3

Remove the right side cover.

4

Remove the left side cover and the engine cover.

5

Remove the tool box and the mud flap.

6

Remove the front and the rear attachments of the original shock absorber and remove it.

NOTE!

Recommendation! Before installing the Öhlins shock absorber:

- clean the vehicle thoroughly
- adjust the length of the shock absorber (check the headlight angle after adjusting the length!)

7

Install the Öhlins shock absorber. Make sure that the shock absorber fill screw is at the top and pointing towards the rear. Lead the hydraulic preload adjuster hose above the shock absorber out to the left side of the vehicle. See figure. Temporarily leave it while attaching the shock absorber.

8

Fasten the front and the rear shock absorber attachments, do not tighten yet.

NOTE!

Lower the motorcycle so that the shock absorber is slightly compressed, before tightening the screws.

9

Tighten the front and rear shock absorber attachments.

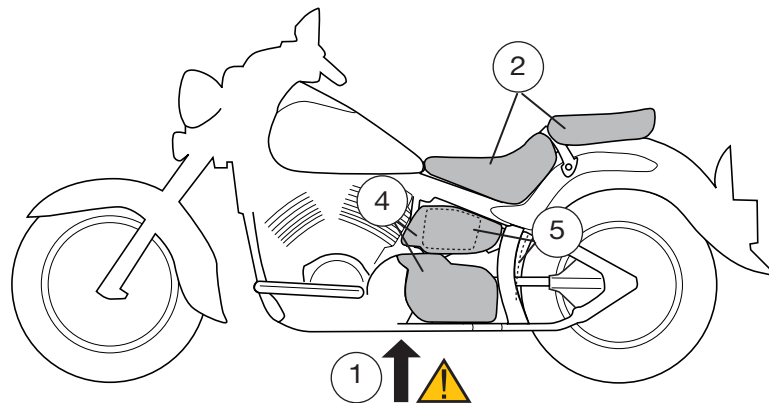

10

Reinstall the mud flap and the tool box.

NOTE!

The hydraulic preload adjuster hose should be lead through the cavity of the tool box as indicated in the figure.

11

Replace the upper left screw of the engine cover with the bracket, spacer and screw provided in this kit. Reinstall the engine cover with the original three screws.

12

Attach the hydraulic preload adjuster to the bracket on the engine cover. Make sure that it is horizontal (See figure 11).

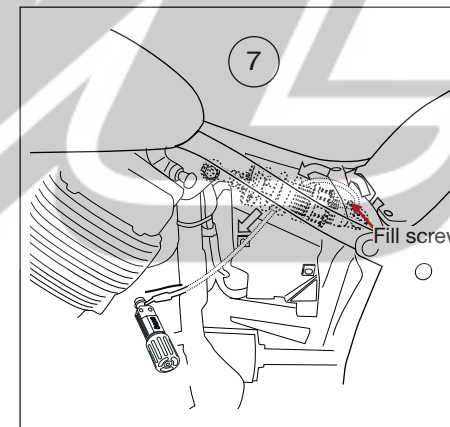

⚠ WARNING!

Make sure that the hydraulic preload adjuster hose runs in soft bends. Also check that it does not come in contact with the exhaust pipe or any sharp edges.

13

Reinstall the side covers and the seats. Make sure that all removed parts are installed in the same way as they were before the installation.

NOTE!

Make sure that all screws are tightened to the correct torque and that nothing fouls or restricts movement of the shock absorber when the suspension is being fully compressed or extended.

