

SPRING GUIDE



Brand	Rider's weight Kg/pounds	Spring	Spring rate N/mm	Titanium Spring
Yamaha YZ 125	55/121	596-03	38	
	60/132	596-04	40	
	65/143	596-05	42	06350-05
	70/154	596-06	44	06350-06
	75/165	596-07	46	06350-07
	80/176	596-08	48	06350-08
	85/187	596-09	50	06350-09
Yamaha YZ 250	65/143	596-07	46	06350-07
	70/154	596-08	48	06350-08
	75/165	596-09	50	06350-09
	80/176	596-10	52	06350-10
	85/187	596-11	54	06350-11
	90/198	596-12	56	06350-12
	95/209	596-13	58	06350-13
Yamaha YZ 250F	70/154	596-06	44	06350-06
	75/165	596-07	46	06350-07
	80/176	596-08	48	06350-08
	85/187	596-09	50	06350-09
	90/198	596-10	52	06350-10
	95/209	596-11	54	06350-11
Yamaha YZ 450F	70/154	596-08	48	06350-08
	75/165	596-09	50	06350-09
	80/176	596-10	52	06350-10
	85/187	596-11	54	06350-11
	90/198	596-12	56	06350-12
	95/209	596-13	58	06350-13

YA 694 - Issued 2006 04 13

Mounting Instructions

Öhlins Shock Absorber YA 694 for Yamaha YZ 450 F 2006

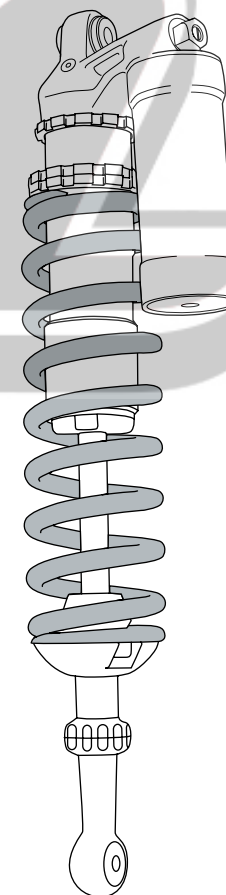

Kit Contents

Before installing this shock absorber, please check the contents of the kit listed below. If any part is missing, please contact your Öhlins dealer.

shock absorber 46PRXW	YA 694 (1)
spring clip	00629-21 (1)
spring adapter (57/ 61)	00543-05 (1)
spring adapter (57/ 63)	00543-06 (1)
c-spanner	00710-02 (1)
Öhlins stickers	00197-01 (2)
Sticker Memo notes	01180-01 (1)
Öhlins Owner's manual	(1)

NOTE!

Spring not included. See the spring guide in this manual.

Please read before installing

Öhlins Racing AB cannot be held responsible for any damage to the shock absorber, vehicle or injury to persons, if the instructions for fitting and maintenance are not followed exactly. Similarly, the warranty will become null and void if the instructions are not adhered to.

In this manual

Safety precautions
Mounting instructions
Changing the spring
Before riding
Set-up data
Adjustments
Spring guide



Öhlins Racing AB, Box 722, S-194 27 Upplands Väsby, Sweden.
Phone +46 8 590 025 00. Fax +46 8 590 025 80.

www.ohlins.com

© Öhlins Racing AB. All rights reserved. Any reprinting or unauthorized use without the written permission of Öhlins Racing AB is prohibited. Printed in Sweden.

SAFETY PRECAUTIONS

Read this manual carefully!

Pay special attention to statements preceded by the following notations:



The Safety alert symbol means: Attention! Your safety is involved!

WARNING

Failure to follow these warning instructions may result in **severe or fatal injury** to anyone working with, inspecting or using this shock absorber, or to bystanders.

CAUTION!

Caution indicates that special precautions must be taken to avoid damage to the shock absorber.

NOTE!

Indicates information that is of importance regarding mounting procedures.

NOTE!

Öhlins products are subject to continuous improvement and development. Therefore, although these instructions include the most up-to-date information available at the time of printing, there may be minor differences between your shock absorber and this manual. Please consult your Öhlins dealer if you have any questions regarding the contents of this manual.

NOTE!

During storage and transportation, especially at high ambient temperature, the oil and grease used for assembling may run out inside the packing and damage the expanded polystyrene packing material. This is not unusual and is in no way detrimental to the shock absorber.

WARNING!

1. **Installing a shock absorber, that is not approved by the vehicle manufacturer, may affect the vehicle's stability.** Öhlins Racing AB cannot be held responsible for any personal injury or damage that may occur after fitting the shock absorber.

2. The **vehicle service manual must be referred to** when installing this shock absorber.

3. Please study and make certain you fully understand the mounting instructions and the owner's manual before handling this shock absorber. If you have any questions regarding proper installation procedures, contact an Öhlins dealer.



ADJUSTMENTS

The Öhlins shock absorber YA 694 features the following adjusters:

Spring preload adjustment

Turn the rings on the shock absorber body using the C-spanner provided in this kit. Turn clockwise for harder adjustment, turn counter-clockwise to release the preload.

Compression damping adjustment

Adjustments are made on top of the reservoir. Low speed adjustment: Slotted centre screw. High speed adjustment: Hexagon screw.

Rebound damping adjustment

Adjust by turning the wheel below the spring clip.

NOTE!

When delivered, the Öhlins shock absorber is dialed to recommended settings for the specific brand and make of the motorcycle. If you have changed the setting, reset according to the following description:

Turn adjusters have a normal right hand thread. Turn the damping adjusters clockwise to fully closed (position zero [0]). Turn counter clockwise to open and count the clicks until you reach the recommended number of clicks. See setup data in this manual.

CAUTION!

Do not use too much force, delicate sealing surfaces can be damaged.

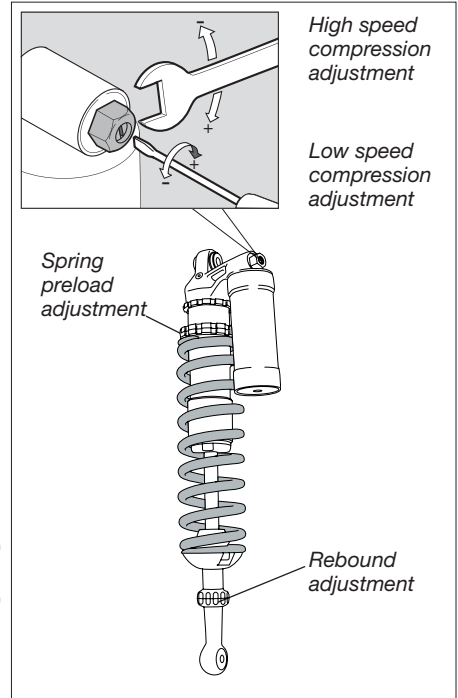

NOTE!

Read more about compression, rebound and spring pre-load in your Öhlins Owner's manual.

BEFORE RIDING

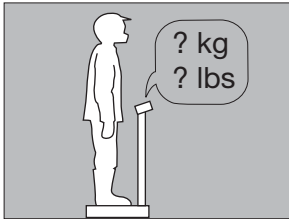
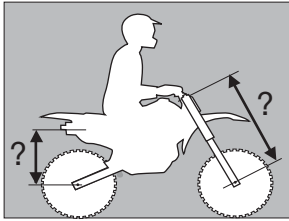

IMPORTANT NOTICE!

Before riding your bike, check sag and ride height according to your Öhlins Owner's manual.

To get the most out of your suspension component it is of great importance to make proper settings and to use the correct spring for your weight - **full riding equipment on!**

We recommend you to read your Öhlins Owner's manual carefully to understand the different effects of the different settings.

SET-UP DATA

Rebound adjustment	25 clicks
Low speed compression	15 clicks
High speed compression	1.5 turns

Free sag, rear	30 ± 5 mm
Free sag, front	30 ± 5 mm
Ride height, rear	102 - 107 mm
Ride height, front	80 ± 5 mm

Shock absorber length	489,5 mm
Stroke	135 mm

NOTE!

Read more about compression and rebound in your Öhlins Owner's manual.

NOTE!

If your measured sag and ride height differ from this set-up data, change the preload according to the section "Adjustments" in this manual.

If, after changing the preload, ride height is still higher than recommended, softer spring/springs must be used. If ride height is lower than recommended, harder spring/springs must be used. Contact your Öhlins dealer for advice.

MOUNTING INSTRUCTIONS

Step 1 - Assembly of Öhlins Shock Absorber with spring

⚠ WARNING!

1. It is advisable to have an Öhlins dealer install the shock absorber.
2. Follow the instructions in the vehicle service manual when changing the shock absorber.
3. When working on a raised vehicle, make sure that it is securely supported to prevent it from tipping over.

1

Measure the free length of the spring (A).

NOTE!

The spring adapter should only be used for the original titanium spring, or an Öhlins titanium spring. Contact your Öhlins dealer for more information.

2

Place the spring adapter 00543-06 (with the largest diameter) where the spring inner diameter is largest. Place the other spring adapter on the other end. See figure. The adapters reduce the freeplay between the spring and the shock absorber cylinder.

3

Fit the spring clip and turn the shock absorber so the spring rests against the spring platform. Turn the lock nut and spring platform so they touch the upper surface of the spring.

4 - Setting the spring pre-load

With a C-spanner, turn the upper spring platform approximately 6 turns (9 mm) clockwise to preload the spring before fitting the shock absorber to the motorcycle.

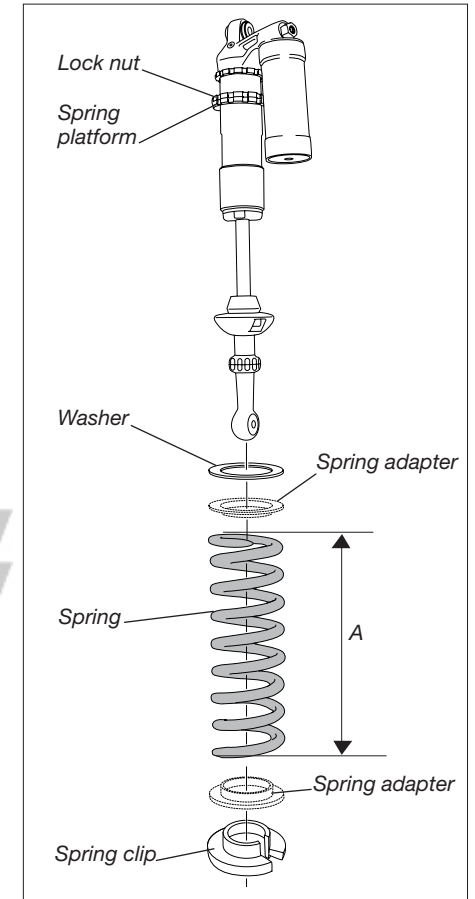

A - B = Pre-load

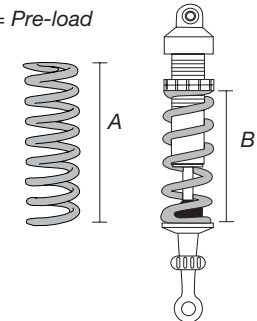

MOUNTING INSTRUCTIONS

Step 2 - Installing the shock absorber

▲ WARNING!

1. It is advisable to have an Öhlins dealer install the shock absorber.
2. Follow the instructions in the vehicle service manual when changing the shock absorber.
3. When working on a raised vehicle, make sure that it is securely supported to prevent it from tipping over.

1

Put the motorcycle on a workstand to raise the rear wheel off the ground.

2

Remove the seat by loosening the two rear attachment screws.

3

Remove the number plate by loosening the lower screw. Remove the silencer by removing the two screws (3b).

4

Remove the two lower screws (one from each side) holding the sub frame (4a). Loosen the upper screw holding the sub frame (4b).

5

Loosen the hose clamp and remove the sub frame and the air box from the carburetor.

6

Loosen the upper and the lower screws of the original shock absorber and remove it.

7

Fit the Öhlins shock absorber in the same way as the original unit. Fasten it with the two original bolts.

8

Place the air box, sub frame and seat back in position and fasten them.

NOTE!

Put the motorcycle back on the floor before tightening the bolts. Make sure the vehicle is secure and will not fall over. You may need an assistant for this.

NOTE!

Make sure that all bolts are tightened to the correct torque and that nothing fouls or restricts movement of the shock absorber when the suspension is being fully compressed or extended.

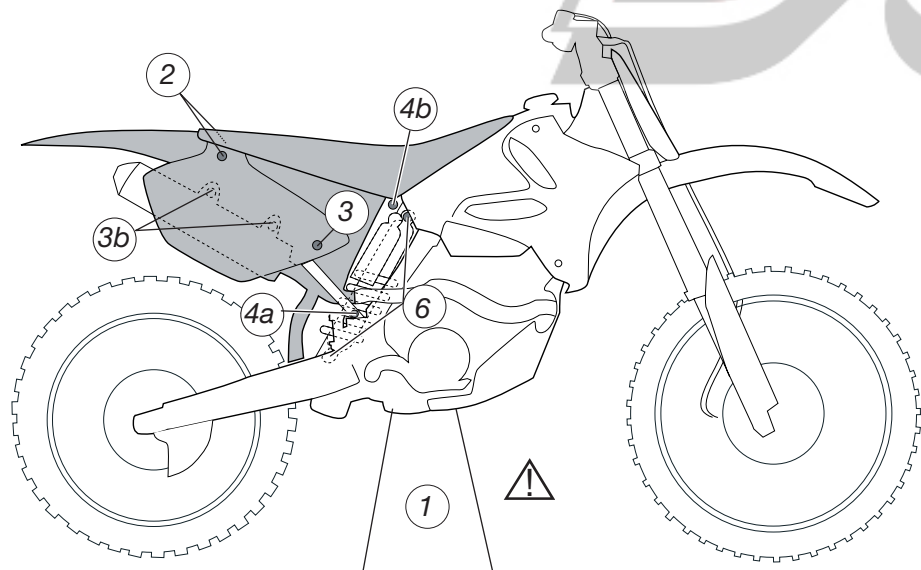

CHANGING THE SPRING

1

To remove the original spring you must first loosen the spring pre-load by turning the upper spring platform counter clockwise with a C-spanner.

2

Remove the spring clip (and adapter if used) and then the original spring.

3

Change the spring and set the new spring pre-load according to page 2.