

Mounting Instructions

Öhlins shock absorber kit YA 593
for Yamaha YZ 250F 2005

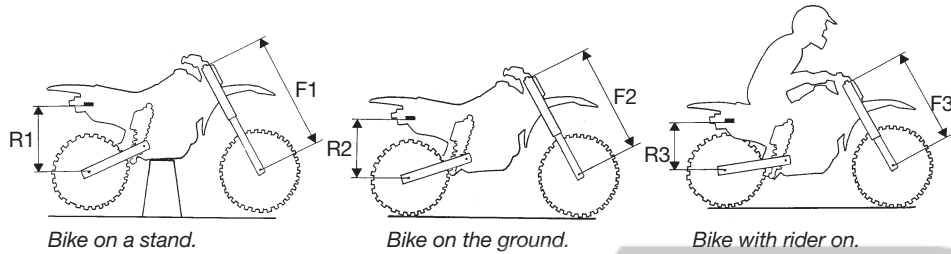

Setup data

Lenght	492 mm
Stroke	132 mm
Rebound adjustment	25 clicks
Compression adjustment	15 clicks
High speed comp. adj	1.5 turn
Free sag, rear	30±5 mm
Free sag, front	30±5 mm
Ride height, rear	100±5 mm
Ride height, front	80±5 mm
Front fork adjustment	std.
Recommended fork springs	std.

Checking sag and ride height

Front suspension

F1. Bike on a stand with the suspension fully extended =

F2. Bike on the ground without rider =

F3. Bike on the ground with rider =

Free sag F1 - F2 =

Ride height F1 - F3 =

Rear suspension

R1. Bike on a stand with the suspension fully extended =

R2. Bike on the ground without rider =

R3. Bike on the ground with rider =

Free sag R1 - R2 =

Ride height R1 - R3 =

NOTE!

*If ride height is higher than recommended, softer spring/springs must be used.
If ride height is lower than recommended, harder spring/springs must be used.
Contact your Öhlins dealer for advice.*

NOTE!

Make notes when the correct spring is mounted and sag and ride height is adjusted.

Spring pre-load _____ mm

Notes

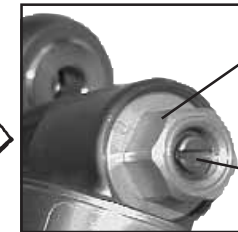
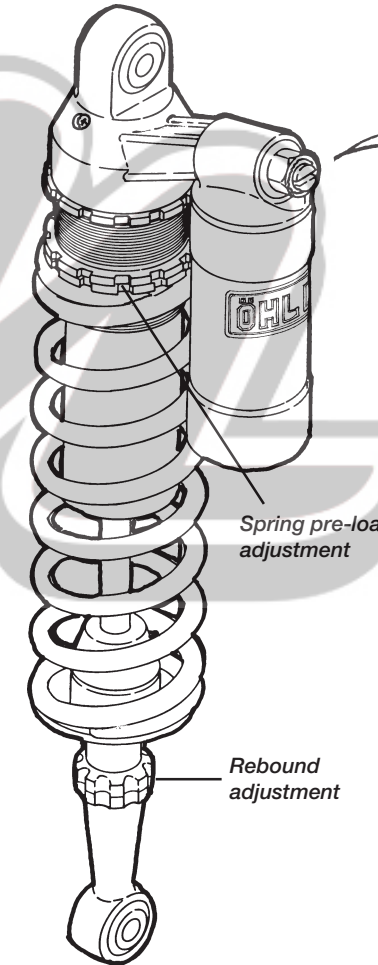

Öhlins shock absorber 46 PRXW

Your Öhlins shock absorber type 46 PRXW features the following adjusters:

Compression damping adjuster

Adjustments are made on top of the reservoir.
Low speed adjustments: Slotted centre screw.
High speed adjustments: Hexagon screw.

Rebound damping adjuster

Adjuster whell on the piston shaft above the end bracket.

Spring pre-load adjuster

Adjustment made by rings on cylinder house.
Use C-spanner.

NOTE!

When delivered the Öhlins shock absorber is dialed to recommended settings for the specific brand and make of the motorcycle. If you have changed the settings, check like this:

The adjusters have a normal right hand thread. Turn the damping adjusters clockwise to fully closed (pos. zero [0]). Turn counter clockwise to open and count the clicks until you reach the recommended number of clicks. See Setup data at last page.

CAUTION!

Do not use too much force, delicate sealing surfaces can be damaged.



Öhlins Racing AB, Box 722, S-194 27 Upplands Väsby, Sweden.
Phone +46 8 590 025 00. Fax +46 8 590 025 80.
www.ohlins.com

YA 593, issued 05 04 05

© Öhlins Racing AB. All rights reserved. Any reprinting or unauthorized use without the written permission of Öhlins Racing AB is prohibited. Printed in Sweden.



Safety signals

Important information concerning safety is distinguished in this manual by the following notations:



*The Safety alert symbol means:
Caution! Your safety is involved.*

⚠ WARNING!

*Failure to follow warning instructions could result in **severe or fatal injury** to anyone working with, inspecting or using the suspension, or to bystanders.*

CAUTION!

Caution indicates that special precautions must be taken to avoid damage to the suspension.

NOTE!

This indicates information that is of importance with regard to procedures.

Before installation

Öhlins Racing AB can not be held responsible for any damage whatsoever to shock absorber or vehicle, or injury to persons, if the instructions for fitting and maintenance are not followed exactly.

Similarly, the warranty will become null and void if the instructions are not adhered to.

⚠ WARNING!

1. Installing a shock absorber, that is not approved by the vehicle manufacturer, may affect the stability of your vehicle. Öhlins Racing AB cannot be held responsible for any personal injury or damage whatsoever that may occur after fitting the shock absorber. Contact an Öhlins dealer or other qualified person for advice.

2. Please study and make certain that you fully understand all the mounting instructions and the owners manuals before handling this shock absorber kit. If you have any questions regarding proper installation procedures, contact an Öhlins dealer or other qualified person.

3. The vehicle service manual must be referred to when installing the Öhlins shock absorber

Öhlins products are subject to continual improvement and development. Consequently, although these instructions include the most up-to-date information available at the time of printing, there may be minor differences between your suspension and this manual. Please consult your Öhlins dealer if you have any questions with regard to the contents of the manual.

NOTE!

During storage and transportation, especially at high ambient temperature, the oil and grease used for assembling may run out inside the packing and damage the expanded polystyrene packing material. This is not unusual and is in no way detrimental to the shock absorber.

Kit contents

Before installing the shock absorber, please check the contents of the kit, listed on the front page of this instruction. If anything is missing, contact your Öhlins dealer.

Description	Pcs.	Part No.
Shock absorber	1	YA 593
Spring clip	1	00629-01
C-spanner	1	00710-02
Sticker Öhlins	2	00197-01
Sticker memo notes	1	01180-01
Owners manual	1	

Notes

Lined area for notes.

Notes

Assembly of Öhlins Shock Absorber with spring separately supplied

1

Make sure that all components are included; spring, spring clip and washer. Measure the free length of the spring.

2

Place the washer between the upper spring platform and the spring. The text on the spring should be facing upward.

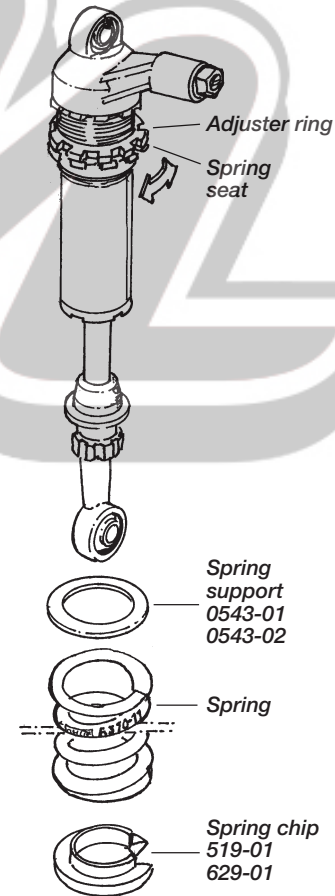

3

Fit the spring clip, turn the shock absorber so the spring rests against the spring seat and turn the rings (upper spring platform and locking nut) so they touch the upper surface of the spring.

4

Turn the upper spring platform approximately 8 laps (10 mm) clockwise to pre-load the spring before fitting the shock absorber to the motorcycle.

5

Fit the shock absorber and measure the free sag with the motorcycle off the ground. (See page 4 for procedures)

6

Let the motorcycle stand on the ground without rider. Fine adjust the pre-load by turning the spring platform until recommended sag is achieved (see Setup data). Measure the spring again and make a note of the pre-load (= free spring length with the length of the compressed spring subtracted).

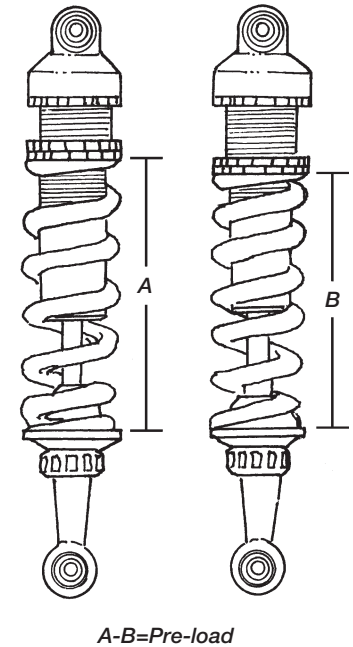

Mounting instructions

1

Put the motorcycle on a stand so the rear wheel has ground clearance. Make sure it's steadily positioned and will not fall over.

⚠ WARNING!

1. It's advisable to have an Öhlins dealer or other qualified person to fit your shock absorber.
2. Instructions in the vehicle service manual are to be followed when changing the shock absorber.
3. When working on a lifted vehicle it must be securely supported to prevent it from falling.

2

Remove the seat by loosening the rear attachment screws.

3

Loosen the rear frame and the hose clamp from the air filter. Disconnect electrical wires. Remove the whole unit with air filter and muffler.

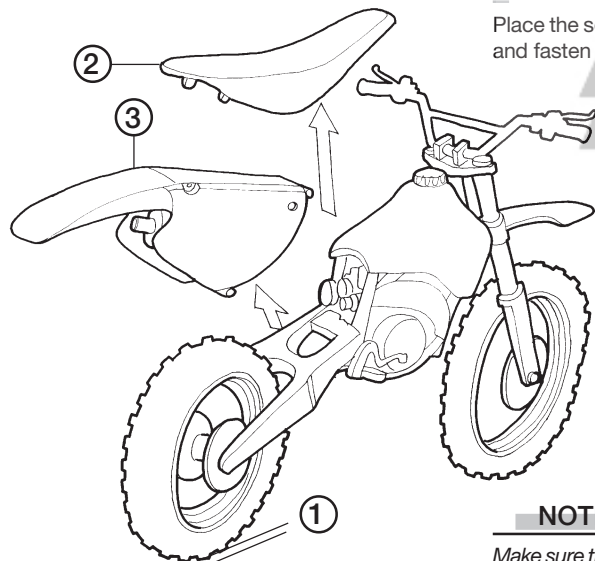

4

Loosen the lower and the upper attachment of the original shock absorber and remove it.

5

Fit the Öhlins shock absorber in the same way as the original unit. Fasten it by using the two original bolts.

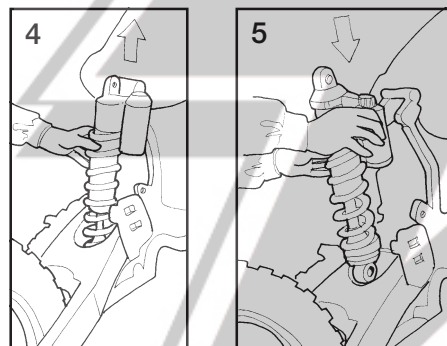

6

Place the seat support and seat back in position and fasten them.

NOTE!

Make sure that all bolts are tightened to the correct torque and that nothing fouls or restricts movement of the shock absorber when the suspension is being fully compressed or extended.

7

Continue your work according to the Owners Manual, section Adjustments.

Spring guideline Moto-X 2005

Brand	Riders weight Kg/pounds	Shock Absorber		Rear	Rear	Front	Front
		Spring Part.No.	Spring rate N/mm	Recom. Static sag	Recom. Ride height	Recom. Static sag	Recom. Ride height
Yamaha YZ 85	35/77	698-05	42	25±5 mm	70±5 mm	25±5mm	60±5 mm
	40/88	698-06	44				
	45/99	698-07	46				
	50/110	698-08	48				
	55/121	698-09	50				
Yamaha YZ 125	55/121	596-04	40	30±5 mm	100±5 mm	30±5 mm	80±5 mm
	60/132	596-05	42				
	65/143	596-06	44				
	70/154	596-07	46				
	75/165	596-08	48				
	80/176	596-09	50				
	85/187	596-10	52				
Yamaha YZ 250	65/143	596-07	46	30±5 mm	100±5 mm	30±5 mm	80±5 mm
	70/154	596-08	48				
	75/165	596-09	50				
	80/176	596-10	52				
	85/187	596-11	54				
	90/198	596-12	56				
	95/209	596-13	58				
Yamaha YZ 250F	65/143	596-06	44	30±5 mm	100±5 mm	30±5 mm	80±5 mm
	70/154	596-07	46				
	75/165	596-08	48				
	80/176	596-09	50				
	85/187	596-10	52				
	90/198	596-11	54				
Yamaha YZ 450F	65/143	596-06	44	30±5 mm	100±5 mm	30±5 mm	80±5 mm
	70/154	596-07	46				
	75/165	596-08	48				
	80/176	596-09	50				
	85/187	596-10	52				
	90/198	596-11	54				
	95/209	596-12	56				
50 mm Shock Absorber							
Yamaha YZ 450F 16 mm pre-load	70/154	6310-08	48	30±5 mm	100±5 mm	30±5 mm	80±5 mm
	75/165	6310-09	50				
	80/176	6310-10	52				
	85/187	6310-11	54				
	90/198	6310-12	56				
	95/209	6310-13	58				