

## Adjustments

### Spring pre-load

Adjust the spring pre-load by turning the rings on the cylinder house. Use the C-spanner provided in this kit.

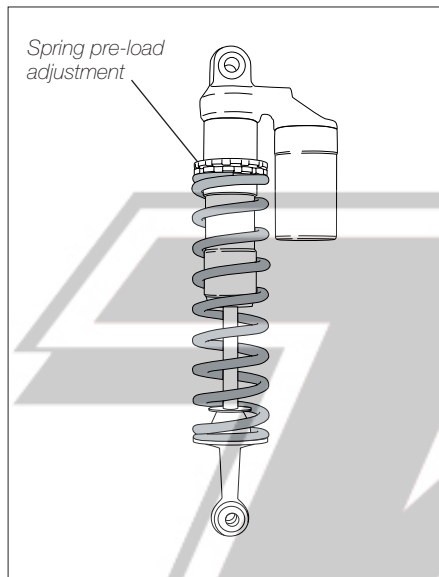

# Mounting Instructions

Öhlins shock absorber kit YA 587  
for Yamaha TT-R 90

## Kit Contents

Before installing the shock absorber, please check the contents of the kit. If anything is missing, please contact your Öhlins dealer.

Description	Part number
Shock absorber	YA 587 (1)
Spring clip	00116-01 (1)
Washer	00153-06 (2)
Screw	00439-07 (2)
Lock nut	05390-01 (2)
C-spanner twin	00710-01 (1)
Sticker Öhlins	00197-01 (2)
Owner's manual	1

## Before Installing

Öhlins Racing AB cannot be held responsible for any damage to shock absorber or vehicle, or injury to persons, if the instructions for fitting and maintenance are not followed exactly.

Similarly, the warranty will become null and void if the instructions are not adhered to.

Öhlins products are subject to continuous improvement and development. Therefore, although these instructions include the most up-to-date information available at the time of printing, there may be minor differences between your suspension and this manual. Please consult your Öhlins dealer if you have any questions regarding the contents of this manual.

## Spring guideline

Rider's weight kg/ lbs	Spring part nr	Spring rate N/mm	Rear rec. static sag
-28 / 62	281-23	35	15 ± 5
28-35/ 62-78	281-12	40	15 ± 5
35+ / 78+	281-07	45	15 ± 5

YA 587, issued 2005 10 13



Öhlins Racing AB, Box 722, S-194 27 Upplands Väsby, Sweden.  
Phone +46 8 590 025 00. Fax +46 8 590 025 80.

[www.ohlins.com](http://www.ohlins.com)

© Öhlins Racing AB. All rights reserved. Any reprinting or unauthorized use without the written permission of Öhlins Racing AB is prohibited. Printed in Sweden.



## Safety Signals

Important information concerning safety is distinguished in this manual by the following notations:



The Safety alert symbol means: Attention! Your safety is involved.

### WARNING!

Failure to follow warning instructions could result in **severe or fatal injury** to anyone working with, inspecting or using the suspension, or to bystanders.

### CAUTION!

Caution indicates that special precautions must be taken to avoid damage to the suspension.

### NOTE!

This indicates information that is of importance with regard to procedures.

### WARNING!

1. Installing a shock absorber, that is not approved by the vehicle manufacturer, may affect the stability of your vehicle. Öhlins Racing AB cannot be held responsible for any personal injury or damage that may occur after fitting the shock absorber. Contact an Öhlins dealer or other qualified person for advice.

2. Please study and make certain that you fully understand all the mounting instructions and the owner's manual before handling this shock absorber kit. If you have any questions regarding proper installation procedures, contact an Öhlins dealer or other qualified person.

3. The vehicle service manual must be referred to when installing the Öhlins shock absorber

### NOTE!

During storage and transportation, especially at high ambient temperature, the oil and grease used for assembling may run out inside the packing and damage the expanded polystyrene packing material. This is not unusual and is in no way detrimental to the shock absorber.

## Mounting Instructions

### WARNING!

1. It is advisable to have an Öhlins dealer or other qualified person to fit the shock absorber.
2. Follow the instructions in the vehicle service manual when changing the shock absorber.
3. When working on a lifted vehicle make sure it is securely supported to prevent it from falling.

### 1

Put the motorcycle on a workstand to raise the rear wheel off the ground. Make sure the vehicle is secure and will not fall over.

### 2

Remove the seat by loosening the two nuts from underneath the rear fender.

### 3

Remove the front screw that holds the rear and side cover. Also remove the clamps from inside the side cover.

### 4

Loosen the rubber band holding the tank, lift up the tank slightly to be able to reach the upper shock absorber attachment.

### 5

Remove the original shock absorber by removing the split pins and bolts that hold the shock absorber.

### 6

Install the Öhlins Shock absorber. Make sure the reservoir is toward the rear of the vehicle and below the shock absorber. **Use the screws, washers and lock nuts included in this kit.**

### 7

Put back the rear and side cover and the seat.

### NOTE!

Make sure that all bolts are tightened to the correct torque and that nothing fouls or restricts movement of the shock absorber when the suspension is being fully compressed or extended.

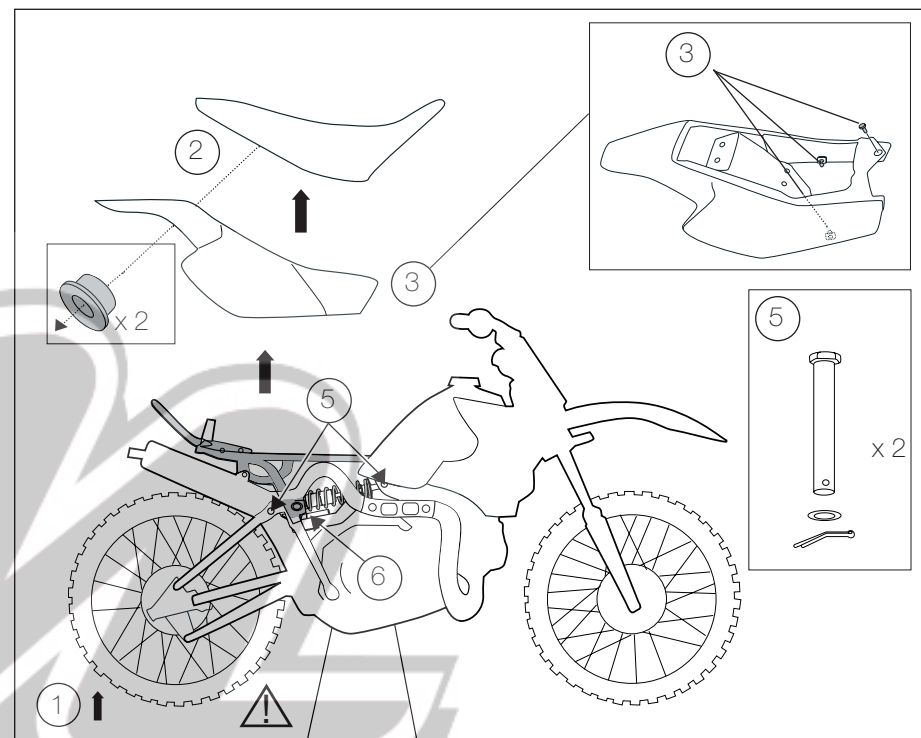

## Checking sag and ride height

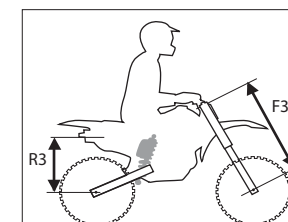
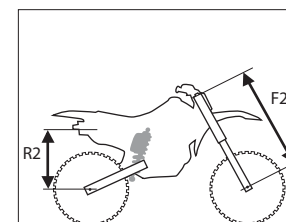
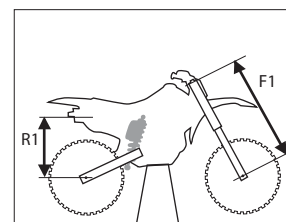

### Setup data

Shock absorber length	275 mm
Shock absorber stroke	60 mm

### NOTE!

Recommended ride height is not specified for this shock absorber because the rider weights differ too much. The values for ride height in your Owner's manual cannot be used, since the stroke for the shock absorber (YA 587) is too short.