

## ADJUSTMENTS

Always ensure that the basic setting made by Öhlins is correct.

### 1 Spring Preload

Use the C-spanner provided in this kit. Turn the spring platform nut (A) clockwise to increase the spring preload, turn counter clockwise to decrease it. Lock the setting with the lock nut (B).

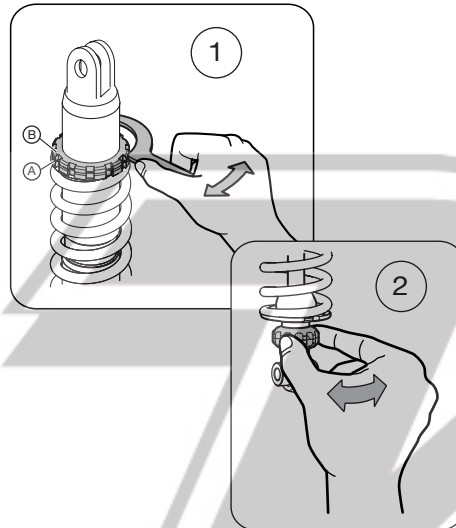

### 2 Rebound

Turn the wheel on the piston shaft above the end eye/bracket. Turn clockwise to increase damping, turn counter clockwise to decrease.

#### NOTE!

When delivered the Öhlins shock absorber is dialed to the recommended settings for the specific vehicle model. If you have changed the setting, reset according to the following:

The adjuster has a right hand thread. Turn the adjuster clockwise to fully closed (pos. zero [0]). Turn counter clockwise to open and count the clicks until you reach the recommended number (see Set-up Data).

#### CAUTION!

Do not use force, delicate sealing surfaces can be damaged. Handtighten only.

### 3 Length

We recommend you to adjust the length before installing the shock absorber to the vehicle. Use two wrenches. Hold the upper nut with one hand and at the same time loosen the lock nut (lower nut). Turn the end eye/ bracket to the desired length. Lock the lock nut. Tightening torque: 40 Nm

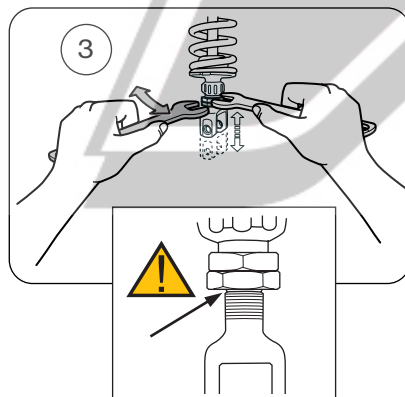

#### ⚠ WARNING!

The adjustable end eye/bracket must not be threaded out more than that the groove is fully visible beneath the lock nut. This is maximum length. After adjusting, make sure that the lock nut is tightened.

# Mounting Instructions

WITH SET-UP DATA

## SHOCK ABSORBER YA549 for Yamaha XV1600 Wild Star

Before installing this shock absorber, check the contents of the kit listed below. If anything is missing, please contact your nearest Öhlins dealer.

#### Kit Contents:

	Art. No.	Pcs.
Shock absorber	YA549	1
C-spanner	00710-02	1
Öhlins Sticker black	00191-13	2
Öhlins Sticker white	00191-20	2
Memo Notes Sticker	01180-01	1
Owner's Manual	07241-02	1

During storage and transportation, especially at high ambient temperature, some of the oil and grease used for assembling may leak and stain the packaging. This is in no way detrimental to the product, wipe off the excessive oil/grease with a cloth.



#### Set-up Data

Spring preload	21 mm	Shock absorber length	311 <sup>+0</sup> <sub>-12</sub> mm
Rebound damping	16 clicks	Stroke	41,5 mm
		Spring	21115-49
		Free spring length	150 <sup>+3</sup> mm

Before installing this product, read the Öhlins Owner's Manual!

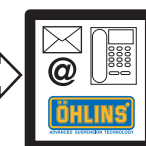

## HOW TO INSTALL

### ⚠ WARNING!

It is advisable to have an Öhlins dealer install the shock absorber.

1

Put the motorcycle on a workstand so that the rear wheel barely touches the ground.

### ⚠ WARNING!

Make sure the vehicle is securely supported so that it will not tip.

2

Loosen the front and the rear attachments of the original shock absorber.

3

Remove the screw, as indicated in the figure and remove the whole unit; pull rod, collar and shock absorber.

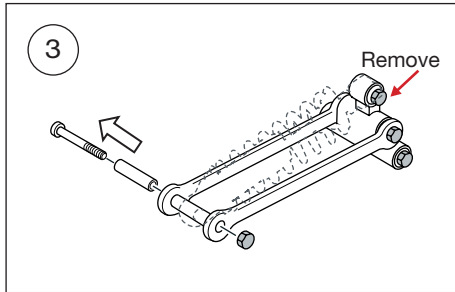

### NOTE!

Recommendation! Before installing the Öhlins shock absorber:

- clean the vehicle thoroughly
- adjust the length of the shock absorber (check the headlight angle after adjusting the length!)

4

Install the Öhlins shock absorber. Put some grease on the collar, make sure not to damage the o-rings. Fasten the front and the rear attachments, but do not tighten yet.

### NOTE!

Lower the motorcycle so that the shock absorber is slightly compressed, before tightening the screws.

5

Tighten the front and rear shock absorber attachments.

6

Make sure that all removed parts are installed in the same way as they were before the installation.

### NOTE!

Make sure that all screws are tightened to the correct torque and that nothing fouls or restricts movement of the shock absorber when the suspension is being fully compressed or extended.

