

Kit Contents

Description	Part No	Pcs
Shock absorber	YA1390	1
Spring clip for springs 57	00629-01	1
O-ring	00576-04	1
Sticker Öhlins	00197-01	2
Owner's manual	07251-02	1

Note!

Please note that this image is a general representation of the product and may differ slightly from your product.

Note!

Please note that during storage and transportation, especially at high ambient temperature, some of the oil and grease used for assembling may leak and stain the packaging. This is in no way detrimental to the product, wipe off the excessive oil/grease with a cloth.

Note!

Before installing this product, check the contents of the kit. If anything is missing, please contact an Öhlins dealer.

Warning!

Before installing this product, read the Öhlins Owner's Manual. The shock absorber/front fork/steering damper is an important part of your vehicle and will affect the stability.

Shock absorber for Yamaha YZ85

YA 1390

Mounting Instructions

MOUNTING INSTRUCTIONS

⚠ Warning!

It is advisable to have an Öhlins dealer install the shock absorber/front fork/steering damper.

⚠ Warning!

If working on a raised vehicle, ensure it is securely supported so that it will not tip.

👁 Note!

Before mounting this product clean the vehicle thoroughly.

👁 Note!

When working on this product, always see the Vehicle Service Manual for vehicle specific procedures and important data.

Spring Guide

Rider's weight* (kg/lbs)	Spring Part no.	Spring rate (N/mm)
< 35/77	00698-06	44
45/99	00698-08	48
50/110	00698-10	52
55/121	00698-11	54
> 60/132	00698-12	56

👁 Note!

Install the spring to the shock absorber before installing the shock absorber on the vehicle.

1

Measure the free length of the spring (A).

2

Loosen the screw on the spring platform clamp so that you can move the spring platform as far up as needed to install the spring.

3

Put the shock absorber up-side-down in a vice so that you can install the spring and the spring clip.

👁 Note!

The spring platform and spring are press fitted. Push hard to install the spring.

4

Measure the spring length. Adjust the spring preload to the recommended setting, see section *Adjustments* and *Set-up data* in this folder.

5

Install the shock absorber to the vehicle according to the procedure in this folder.

Check sag and ride height (see the Owner's Manual) and adjust the spring preload again if necessary.

👁 Note!

Tighten the screw on the spring platform clamp before riding the motorcycle.

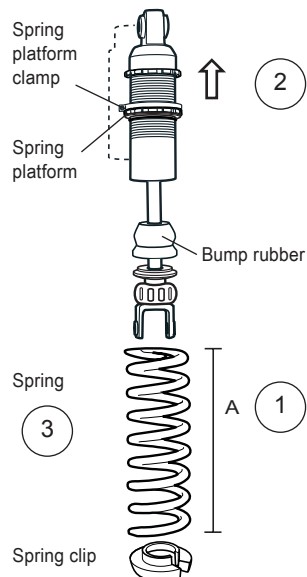

MOUNTING INSTRUCTIONS

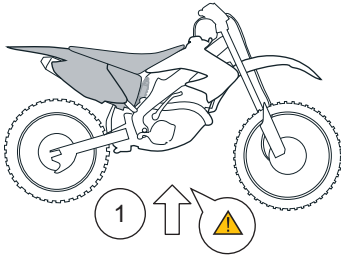

Note!

Install the spring to the shock absorber before installing the shock absorber on the vehicle.

1

Install the Öhlins shock absorber according to the vehicle manual. Use original attachment screws.

2

Make sure that all removed parts are reinstalled in the same way as they were before the installation of the Öhlins shock absorber.

Caution!

Ensure that all screws are tightened to the correct torque and that nothing fouls or restricts movement of the shock absorber/front fork/steering damper when the suspension is fully compressed or extended.

Caution!

After installing this product, take a test ride at low speed to make sure that your vehicle has maintained its stability.

Warning!

If the suspension makes an abnormal noise, or the function is irregular, or if you notice any leakage from the product, please stop the vehicle immediately and return the product to an Öhlins Service Centre.

ADJUSTMENTS

⚠ Warning!

Before riding, always make sure that the basic settings made by Öhlins are according to recommended Set-up Data. Read about adjustments and setting up in the Öhlins Owner's Manual before you make any adjustments. Contact an Öhlins dealer if you have any questions about setting up.

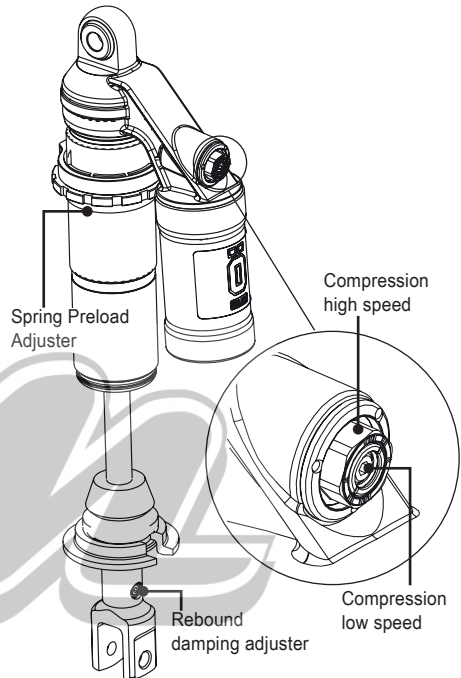

SET-UP DATA

Length	403	mm
Stroke	104	mm
Rebound	18	clicks
Compression		
low	12	clicks
high	11	
Sag and Ride Height		
R1-R2	25±5	mm
R1-R3	70±5	mm

👁 Öhlins products are subject to continuous improvement and development, therefore, although these instructions include the most up-to-date information available at the time of printing, minor updates may occur.

To find the latest information contact an Öhlins distributor. Please contact Öhlins if you have any questions regarding the contents in this document.

Part no. MI_YA1390_0
Issued 2013-04-26



© Öhlins Racing AB. All rights reserved. Any reprinting or unauthorized use without the written permission of Öhlins Racing AB is prohibited.

Öhlins Racing AB
Box 722
S-194 27 Upplands Väsby, Sweden
Phone +46 8 590 025 00
fax +46 8 590 025 80



www.ohlins.com