

# Adjustments

## ⚠ Warning!

Before riding, always make sure that the basic settings made by Öhlins are according to recommended Set-up Data. Read about adjustments and setting up in the Öhlins Owner's Manual before you make any adjustments. Contact an Öhlins dealer if you have any questions about setting up the shock absorber.

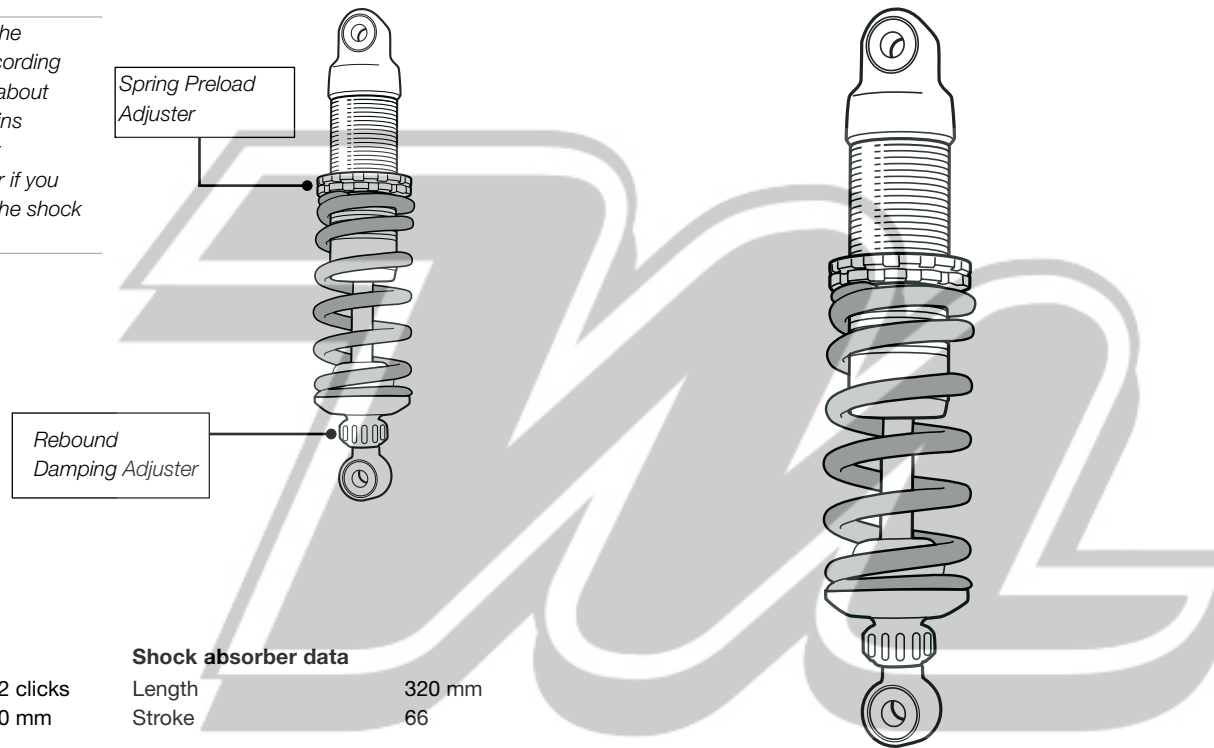

Before installing this product, check the contents of the kit. If anything is missing, please contact an Öhlins dealer.

### Kit Contents

	Part No.	Pcs.
Shock Abs. S46DR1	YA 009	1
C-Spanner	00710-02	1
Öhlins Sticker	00192-01	2
Memo Notes Sticker	01180-01	1
Owner's Manual	07241-02	1

# Set-up Data

### Recommended set-up

Rebound	12 clicks
Spring Preload	10 mm

### Shock absorber data

Length	320 mm
Stroke	66

### Spring

Part No.	Rate
01095-44	120 N/mm

### Free Sag and Ride Height

R1 - R2	= 12 mm
R1 - R3	= 30 mm

Please note that during storage and transportation, especially at high ambient temperature, some of the oil and grease used for assembling may leak and stain the packaging. This is in no way detrimental to the product, wipe off the excessive oil/grease with a cloth.

## ⚠ Warning!

Before installing this product, read the Öhlins Owner's Manual. The shock absorber is an important part of your vehicle and will affect the stability.

Öhlins products are subject to continuous improvement and development, therefore, although these instructions include the most up-to-date information available at the time of printing, minor updates may occur.

To find the latest information contact your Öhlins distributor. Please consult your Öhlins dealer if you have any questions regarding the contents in this document.

Part no. YA009\_0  
Issued 2010-02-23



# Shock Absorber for Yamaha FZ1 YA 009

## Mounting Instructions

© Öhlins Racing AB. All rights reserved. Any reprinting or unauthorized use without the written permission of Öhlins Racing AB is prohibited.

Öhlins Racing AB  
Box 722  
S-194 27 Upplands Väsby, Sweden  
Phone +46 8 590 025 00  
fax +46 8 590 025 80



[www.ohlins.com](http://www.ohlins.com)



**⚠ Warning!**

*It is advisable to have an Öhlins dealer install the shock absorber.*

*When installing, consult your Vehicle Service Manual.*

**1**  
Put the motorcycle on a workstand so that the rear wheel barely touches the ground.

**⚠ Warning!**

*Make sure the vehicle is securely supported so that it will not tip.*

**2**  
Remove the covers on the right and left side of the vehicle.

**3**  
Loosen the ABS unit (two screws - see figure) to reach the upper attachment of the original shock absorber.

**4**  
Loosen the upper (A) and the lower (B) attachment of the original shock absorber and remove it. Also remove the lower attachment for the triangle link (C).

**👁 Note!**

*Before installing the Öhlins shock absorber clean the vehicle thoroughly.*

**5**  
Install the Öhlins Shock absorber from below.

**👁 Note!**

*Lower the motorcycle so that the shock absorber is slightly compressed, before tightening the screws.*

**6**  
Tighten the upper and lower attachment screws, then tighten the lower attachment of the triangle link.

**7**  
Make sure that all removed parts are reinstalled in the same way as they were before the installation of the Öhlins Shock Absorber.

**👁 Caution!**

*Make sure that all screws are tightened to the correct torque and that nothing fouls or restricts movement of the shock absorber when the suspension is fully compressed or extended.*

