

ADJUSTMENTS

4 Length

We advise to remove the shock absorber before adjusting the length. Use two wrenches. Hold the upper nut with one hand and at the same time loosen the lock nut (lower nut). Turn the end eye/bracket to the desired length. 1 turn = 1 mm length adjustment. Lock the lock nut. Tightening torque: 40 Nm

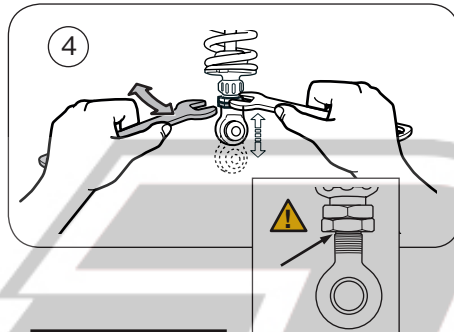

⚠ WARNING!

The adjustable end eye/bracket must not be threaded out more than that the groove is fully visible beneath the lock nut. This is maximum length. After adjusting, make sure that the lock nut is tightened.

Mounting Instructions

WITH SET-UP DATA

SHOCK ABSORBER TR 807 for Triumph 1050 Speed Triple

Before installing this shock absorber, check the contents of the kit listed below. If anything is missing, please contact your nearest Öhlins dealer.

Kit Contents:

	Part no.	Pcs.
Shock absorber	TR 807	1
Öhlins Sticker	00192-01	2
Memo Notes Sticker	01180-01	1
Owner's Manual	07241-02	1

During storage and transportation, especially at high ambient temperature, some of the oil and grease used for assembling may leak and stain the packaging. This is in no way detrimental to the product, wipe off the excessive oil/grease with a cloth.

Set-up Data

Shock absorber length	371.5 mm
Stroke	61.5 mm
Spring preload	12 mm
Compression damping	14 clicks
Rebound damping	16 clicks
Spring	01095-54
Free spring length	180 mm (140N/mm)

Before installing this product, read the Öhlins Owner's Manual!



Öhlins Racing AB, Box 722, S-194 27 Upplands Väsby, Sweden.
Phone +46 8 590 025 00 Fax +46 8 590 025 80
www.ohlins.com

© Öhlins Racing AB. All rights reserved.
Any reprinting or unauthorized use without the
written permission of Öhlins Racing AB
is prohibited. Printed in Sweden.



Mounting Instruction TR 807_0 Issued 2008-06-09
This instruction and other documents
can be downloaded from
www.ohlins.com

HOW TO INSTALL

⚠ WARNING!

It is advisable to have an Öhlins dealer install the shock absorber.

1

Put the motorcycle on a workstand so that the rear wheel barely touches the ground.

⚠ WARNING!

Make sure the vehicle is securely supported so that it will not tip.

2

Remove the seat and the side fairings.

3

Remove the silencers and the rear part of the exhaust system. Consult your Vehicle Service Manual.

4

Loosen the screw to the brake fluid cup. Loosen the fuel tank (one screw), lift and pull the tank towards the rear.

5

Loosen the hose clamp holding the external reservoir of the original shock absorber.

6

Loosen and remove the two lower bolts that hold the rear sub frame. Loosen the upper bolts so that the rear frame can be raised and the gas reservoir removed.

7

Loosen the lower and then the upper attachment bolts, remove the original shock absorber.

NOTE!

Recommendation: Before installing the Öhlins shock absorber clean the vehicle thoroughly.

8

Install the Öhlins shock absorber above the rear wheel. Slightly raise the rear sub frame so that the shock absorber can be installed. Do not tighten the attachment bolts yet.

NOTE!

Lower the motorcycle so that the shock absorber is slightly compressed, before tightening the screws.

8 Correct position of the Öhlins Shock Absorber. The compression adjuster pointing to the right side of the vehicle.

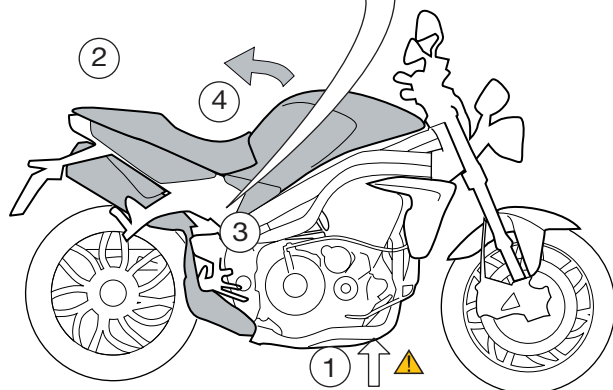

9

Tighten the attachment bolts to the correct torque according to the Triumph specs.

10

Reinstall the sub frame, fuel tank, brake fluid cup, exhaust, side fairings and seat.

NOTE!

Make sure that all screws are tightened to the correct torque and that nothing fouls or restricts movement of the shock absorber when the suspension is fully compressed or extended.

ADJUSTMENTS

Before riding, always ensure that the basic settings made by Öhlins are intact.

1 Spring preload

Turn the hexagon screw on the hydraulic adjuster to set the spring preload. Turn clockwise to increase, turn counter clockwise to decrease.

2 Compression

Adjust by turning the knob on top of the reservoir. Turn clockwise to increase damping, turn counter clockwise to decrease.

3 Rebound

Turn the wheel on the piston shaft above the end eye/ bracket. Turn clockwise to increase damping, turn counter clockwise to decrease.

NOTE!

When delivered the Öhlins shock absorber is dialed to recommended settings for the specific brand and make of the vehicle. If you have changed the setting, reset according to the set-up data in the Mounting Instruction.

To reset: The adjuster has a right hand thread. Turn the adjuster clockwise to fully closed (pos. zero [0]). Turn counter clockwise to open and count the clicks until you reach the recommended number in the Set-up data.

CAUTION!

Do not use force, delicate sealing surfaces can be damaged. Handtighten only.

