

7

Fit the left bracket plate with the long spacers and original bolts and tighten.

8

Fit the Öhlin shock absorber with the long bolt and spacers supplied to the upper bracket and with the supplied to the lower bracket on the swing. The fluid reservoir is to be faced the left side of the motorcycle. The Öhlins shock absorber will replace both the original spring and the rotation shock absorber.

9

Reassemble the pedal support, the foot rest plate and the rear tank bracket. Finally fit the seat with the two bolts.

NOTE!

Make sure that all bolts are tightened to the correct torque and that nothing fouls the shock absorber when the suspension is being compressed. See: Motorcycle workshop manual.

WARNING

Certain modifications are necessary to install the Öhlins shock absorber. It is vital that the mounting instructions are carefully followed.

10

Continue your work according to Owners Manual, section Adjustments

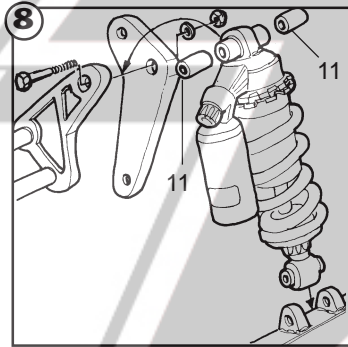
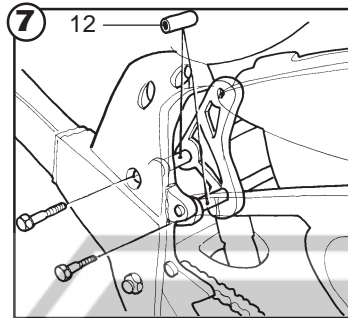

Notes:

Mounting Instructions

SU806 - SUZUKI TL 1000 R

Kit contents

1. Shock absorber, Type 46PRC	SU 806	
2. Sticker Öhlins	00192-01	2
3. Nut M12 DIN 985	00430-06	2
4. Washer PS 12/18/1 FZB	00578-02	4
5. Washer PS 10/16/1	00578-03	1
6. Bolt MC6S 12x70	01046-28	1
7. Bolt MC6S 12x130	01046-29	1
8. Bracket TL 1000R left	03106-02	1
9. Bracket TL 1000R right	03106-03	1
10. Spacer 10/20/17	03171-01	1
11. Spacer 12/20/22	03171-02	3
12. Spacer 10/20/38	03171-03	2
13. C-spanner single	00710-02	1
14. Owners manual		1
15. Sticker Memo Notes	01180-01	1

Set-up data

Lenght	253 mm
Stroke	49 mm
Preload spring	12 mm
Compression adjustment	10
Rebound adjustment	13

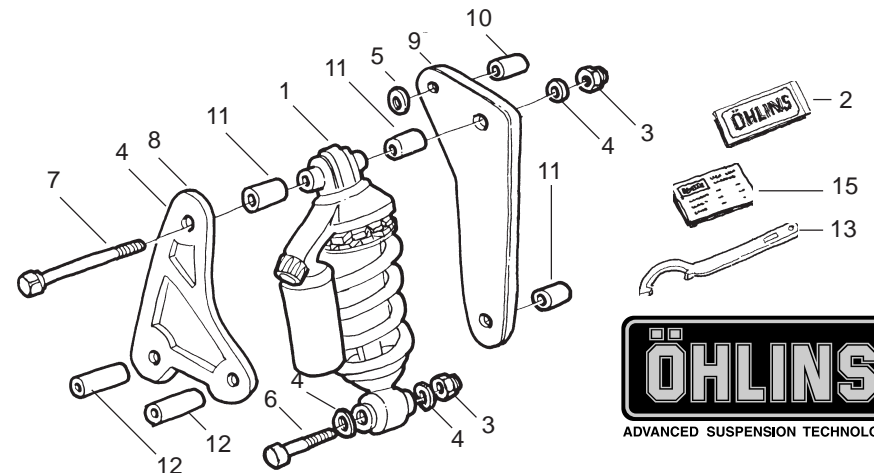

Traction, handling,
comfort and safety



ADVANCED SUSPENSION TECHNOLOGY

Öhlins Racing AB, Box 722, S-194 27 Upplands Väsby, Sweden.
Phone +46 8 590 025 00, fax +46 8 590 025 80.

SU 806, ISSUED 99 02 16



ADVANCED SUSPENSION TECHNOLOGY

Safety signals

Important information concerning safety is distinguished in this manual by the following notations



The Beware sign means:
Pay attention!
Your safety is at risk.

⚠ WARNING!

Failure to follow Warning text could result in **serious or fatal injury** to anyone working with, inspecting or using the suspension, or to bystanders.

CAUTION!

Caution indicates special precautions that must be taken to avoid damage to the suspension.

NOTE!

This indicates information that is of importance with regard to procedures

Kit contents

Before installing the shock absorber kit, please check the contents, listed on the front page of this instruction. If anything is missing, contact your Öhlins dealer.

NOTE!

During storage and transportation, especially at high ambient temperature, the oil and grease used for assembling may run out inside the packing and damage the expanded polystyrene packing material. This is not unusual and is in no way detrimental to the shock absorber.

Before you start

⚠ WARNING!

Installing a shock absorber, that is not approved by the motorcycle manufacturer, may affect the stability of your motorcycle. Öhlins Racing AB can't be held responsible for any personal injury or damage whatsoever which may occur after fitting the shock absorber.

Öhlins Racing AB can not be held responsible for any damage whatsoever to spare parts, or injury to persons, if the instructions for servicing and maintenance are not followed exactly. Similarly, the guarantees relating to performance and reliability will become null and void if the instructions are not adhered to.

⚠ WARNING!

Please study the mounting instructions and the owner's and workshop manuals thoroughly before handling this shock absorber kit.

⚠ WARNING!

When installing the Öhlins shock absorber the motorcycle workshop manual must be at hand.

NOTE!

Öhlins products are subject to continual improvement and development in design and quality. Consequently, although these instructions include the most up-to-date information available at the time of printing, there may be minor differences between your suspension and this manual. Please consult your Öhlins dealer if you have any questions concerning the manual.

Mounting instructions

1

Put the motorcycle on a stand so that the rear wheel is clear of the ground. Make sure it is fixed so it will not fall over.

⚠ WARNING!

1. It's advisable to have an Öhlins dealer or other qualified person to fit your shock absorber.

2. Instructions in the motorcycle workshop manual are to be followed when changing the shock absorber.

3. When working on the motorcycle it must be securely supported to prevent it from falling over.

2

Remove the two bolts holding the front seat and lift it off. Loosen the rear tank bracket, so the rear end of the tank can be raised. Remove the plate at the left foot rest.

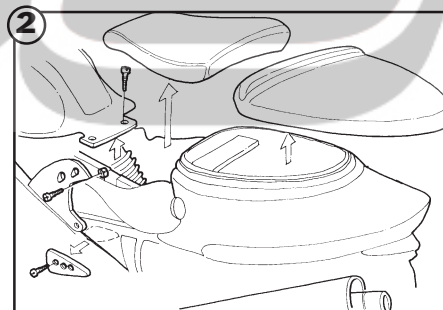

3

Remove the foot rest support on the right side by loosening the three bolts.

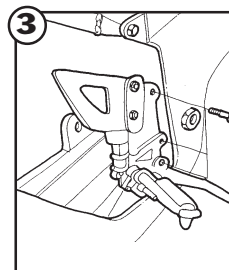

4

Loosen the linkage from the frame and from the swinging arm rear fork. Loosen the upper mount of the original spring unit.

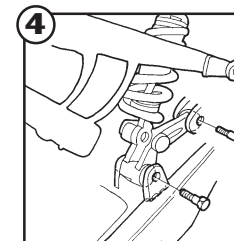

5

Loosen the three bolts of the original shock absorber and the bracket on the inside and take the whole unit, including linkage, out by turning it carefully and pulling. Then pull out the original spring unit together with the triangle link the same way.

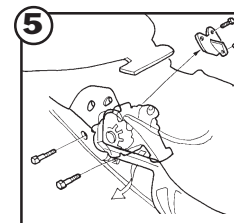

6

Fit the right bracket plate with the spacer (10, 11) and original bolts and tighten.

NOTE!

The spacing washer is to be positioned between the plate and the inside of the left upper.

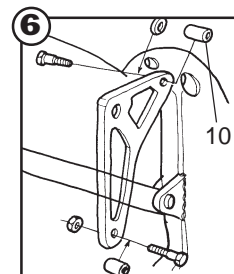

© Öhlins Racing AB.
All rights reserved.

Any reprinting or unauthorized use without the written permission of Öhlins Racing AB is prohibited.
Printed in Sweden.