

# Adjustments

## ⚠ Warning!

Before riding, always make sure that the basic settings made by Öhlins are according to recommended Set-up Data. Read about adjustments and setting up in the Öhlins Owner's Manual before you make any adjustments. Contact an Öhlins dealer if you have any questions about setting up the shock absorber.

## Öhlins Shock Absorber S46PR1C2LS SU 718

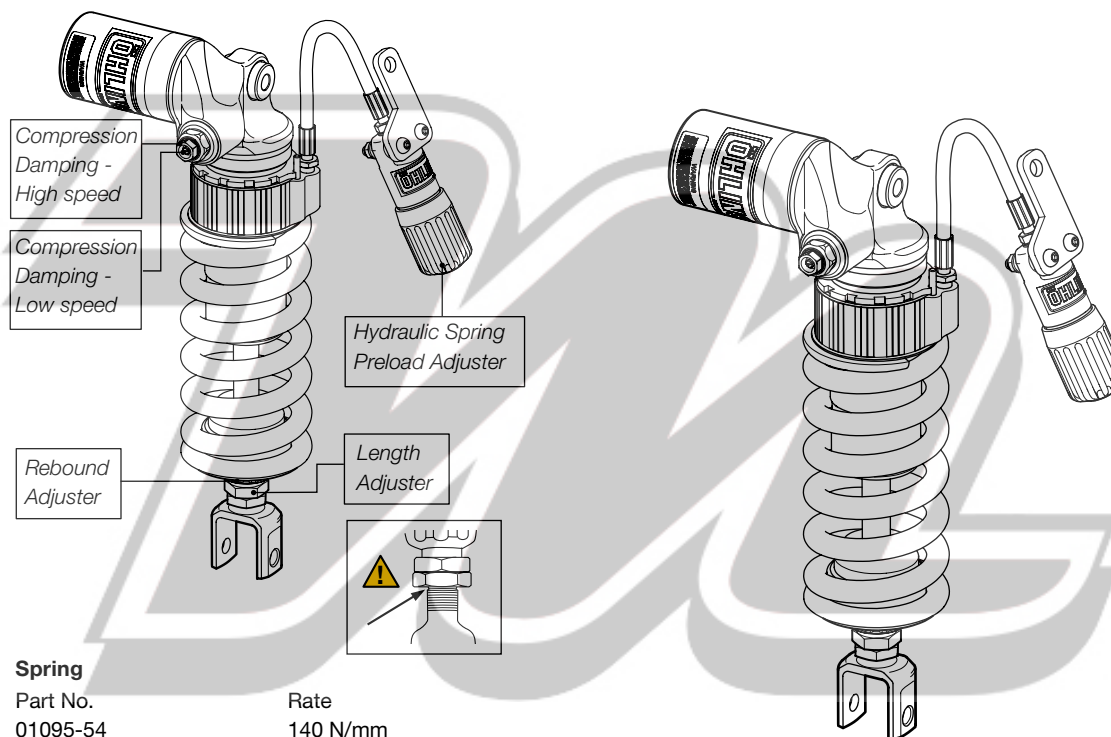

Before installing this product, check the contents of the kit. If anything is missing, please contact your nearest Öhlins dealer.

### Kit Contents

|                    | Part No.   | Pcs. |
|--------------------|------------|------|
| Shock abs.         | S46PR1C2LS | 1    |
| Tie wrap           | 00231-01   | 2    |
| Screw M10          | 00439-02   | 1    |
| Screw MC6S         | 01046-25   | 1    |
| Öhlins Sticker     | 00192-01   | 2    |
| Memo Notes Sticker | 01180-01   | 1    |
| Owner's Manual     | 07241-02   | 1    |

Please note that during storage and transportation, especially at high ambient temperature, some of the oil and grease used for assembling may leak and stain the packaging. This is in no way detrimental to the product, wipe off the excessive oil/grease with a cloth.

## ⚠ Warning!

Before installing this product, read the Öhlins Owner's Manual. The shock absorber is an important part of your vehicle and may affect the stability of your vehicle.

# Set-up Data

## Recommended set-up

|                |           |
|----------------|-----------|
| Rebound        | 14 clicks |
| Compression    |           |
| Low speed      | 12 clicks |
| High speed     | 30 clicks |
| Spring Preload | 15 mm     |

## Spring

|          |          |
|----------|----------|
| Part No. | Rate     |
| 01095-54 | 140 N/mm |

Öhlins products are subject to continuous improvement and development, therefore, although these instructions include the most up-to-date information available at the time of printing, minor updates may occur.

To find the latest information contact your Öhlins distributor. Please consult your Öhlins dealer if you have any questions regarding the contents in this document.

Part no. SU\_718\_0  
Issued 2008-11-10



# Shock Absorber for Suzuki Hayabusa SU 718

## Mounting Instructions

© Öhlins Racing AB. All rights reserved. Any reprinting or unauthorized use without the written permission of Öhlins Racing AB is prohibited.

Öhlins Racing AB  
Box 722  
S-194 27 Upplands Väsby, Sweden  
Phone +46 8 590 025 00  
fax +46 8 590 025 80



[www.ohlins.com](http://www.ohlins.com)



# How to install

## ⚠ Warning!

It is advisable to have an Öhlins dealer install the shock absorber.

When installing, consult your Vehicle Service Manual.

**1**  
Put the motorcycle on a workstand so that the rear wheel barely touches the ground.

## ⚠ Warning!

Make sure the vehicle is securely supported so that it will not tip.

**2**  
Open the rear seat lock and remove the seat.

**3**  
Loosen the two bolts holding the front seat, remove it.

**4**  
Remove the four bolts and loosen the passenger handle bar.

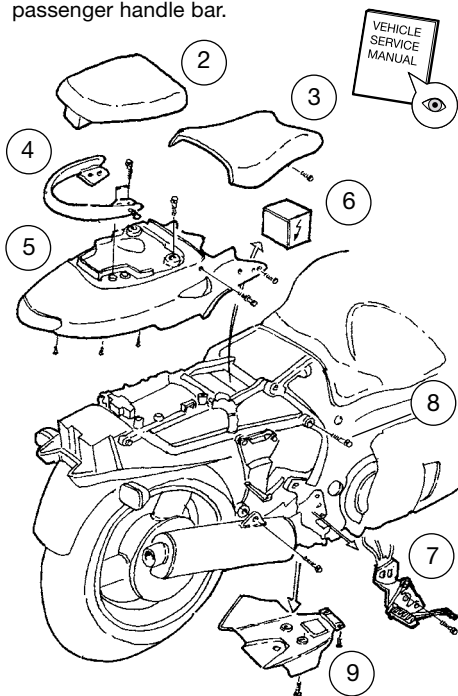

**5**  
Loosen and remove the rear end cover by removing the six attachment bolts and the six plastic fasteners.

**6**  
Remove the battery. Remove the bolt and attachment holding the electrical wires on the left side.

**7**  
Loosen the right side foot rest bracket by removing the three bolts. Leave it hanging by the brake hose.

**8**  
Loosen the rear frame bolts. Remove the lower bolts and raise the rear frame as far up as possible.

**9**  
Loosen the lower cover plate under the swing.

## 👁 Note!

Make sure that the brake reservoir or electrical wires do not restrict raising the rear frame.

**10**  
Loosen the triangle link from the rear swing attachment. Loosen the lower shock absorber bracket. Let the triangle link remain attached to the frame.

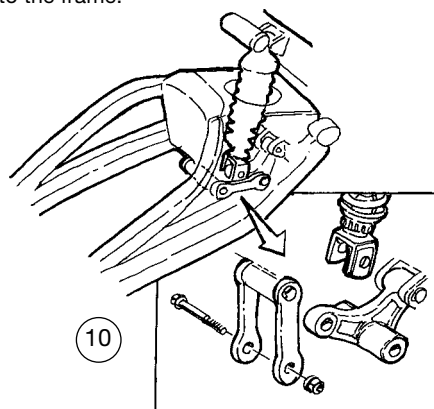

**11**  
Loosen the upper shock absorber attachment and remove it from the top and out to the left side of the motorcycle.

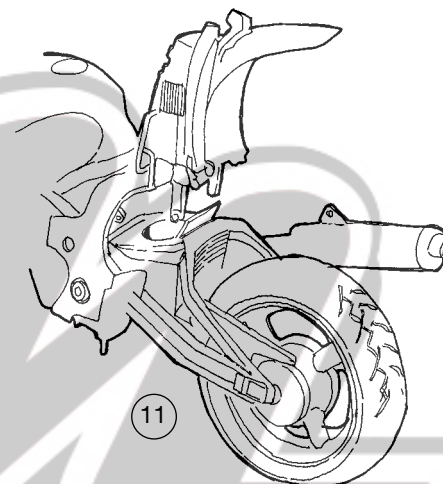

## 👁 Note!

Before installing the Öhlins shock absorber clean the vehicle thoroughly.

**12**  
Install the Öhlins shock absorber from the left side, down into the rear swing. First, install the upper bracket, then attach it to the triangle link. Fasten the triangle link to the pull rods. Do not tighten yet.

**13**  
Install the hydraulic preload adjuster to the silencer bracket with the screw (01046-25) provided. Fasten the hose with the tie wraps provided.

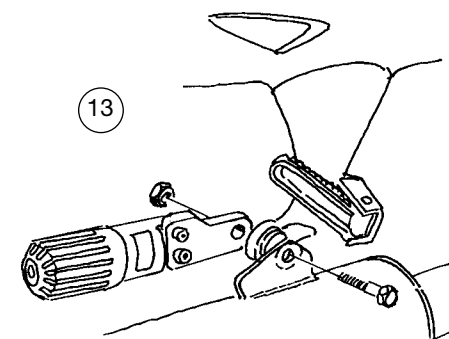

## 👁 Note!

Lower the motorcycle so that the shock absorber is slightly compressed, before tightening the screws.

**14**  
Tighten the upper and the lower attachments of the shock absorber and the upper pull link attachment.

**15**  
Reinstall all removed parts to the motorcycle. Make sure that all removed parts are reinstalled in the same way as they were before the installation of the Öhlins shock absorber.

## 👁 Caution!

Make sure that nothing interferes with the hose and the adjuster when the rear wheel suspension is fully extended/compressed.

## 👁 Caution!

Make sure that all screws are tightened to the correct torque and that nothing fouls or restricts movement of the shock absorber when the suspension is fully compressed or extended.