

Mounting Instructions

Öhlins shock absorber kit SU 591
for Suzuki RM 125 2005

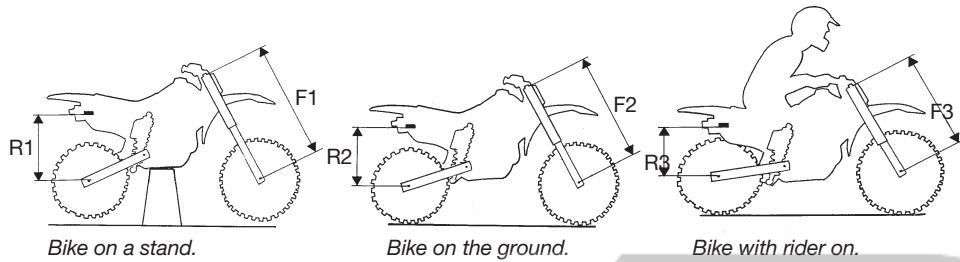

Setup data

Length	480.5 mm
Stroke	128.5 mm
Rebound adjustment	25 clicks
Compression adjustment	15 clicks
High speed comp. adj	1.5 turns
Free sag, rear	30±5 mm
Free sag, front	30±5 mm
Ride height, rear	100±5 mm
Ride height, front	80±5 mm
Front fork adjustment	std.
Recommended fork springs	std.

Checking sag and ride height

Front suspension

F1. Bike on a stand with the suspension fully extended	=
F2. Bike on the ground <u>without</u> rider	=
F3. Bike on the ground <u>with</u> rider	=
Free sag	F1 - F2 =
Ride height	F1 - F3 =

Rear suspension

R1. Bike on a stand with the suspension fully extended	=
R2. Bike on the ground <u>without</u> rider	=
R3. Bike on the ground <u>with</u> rider	=
Free sag	R1 - R2 =
Ride height	R1 - R3 =

NOTE!

*If ride height is higher than recommended, softer spring/springs must be used.
If ride height is lower than recommended, harder spring/springs must be used.
Contact your Öhlins dealer for advice.*

NOTE!

Make notes when the correct spring is mounted and sag and ride height is adjusted.

Spring pre-load _____ mm

Notes

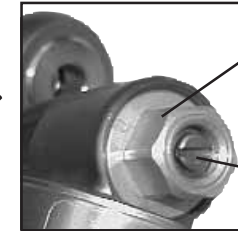
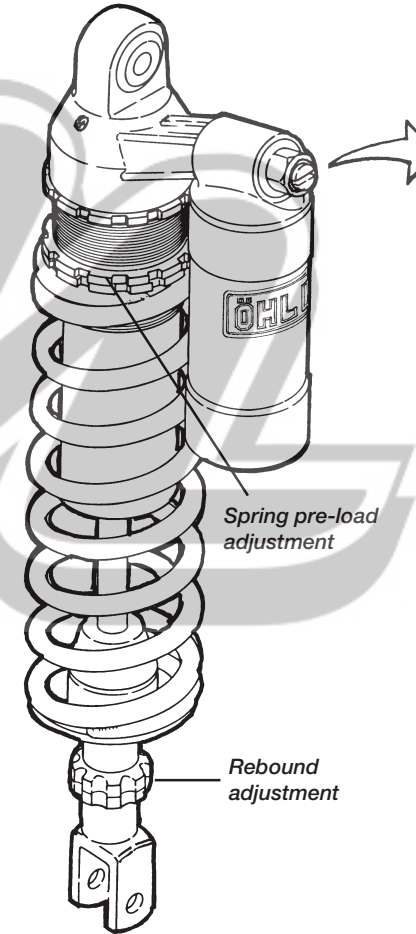

High speed compression adjustment

Low speed compression adjustment

Spring pre-load adjustment

Rebound adjustment

Öhlins shock absorber 46 PRX

Your Öhlins shock absorber type 46 PRX features the following adjusters:

Compression damping:

Adjustments are made on top of the reservoir.
Low speed adjustments: Slotted centre screw.
High speed adjustments: Hexagon screw.

Rebound damping

Adjuster wheel on the piston shaft above the end bracket.

Spring preload

Adjustment made by rings on cylinder house.
Use C-spanner.

NOTE!

When delivered the Öhlins shock absorber is dialed to recommended settings for the specific brand and make of the motorcycle. If you have changed the settings, check like this:

The adjusters have a normal right hand tread. Turn clockwise to fully closed. Turn counter clockwise to open and count the clicks until you reach the recommended number of clicks.

CAUTION!

Do not use too much force, delicate sealing surfaces can be damaged. Do use fingers only.



Öhlins Racing AB, Box 722, S-194 27 Upplands Väsby, Sweden.
Phone +46 8 590 025 00. Fax +46 8 590 025 80.
www.ohlins.com

SU 591, issued 05 04 05

© Öhlins Racing AB. All rights reserved. Any reprinting or unauthorized use without the written permission of Öhlins Racing AB is prohibited. Printed in Sweden.



Notes

Assembly of Öhlins Shock Absorber with spring separately supplied

1

Make sure that all components are included; spring, spring clip and washer. Measure the free length of the spring.

2

Place the washer between the upper spring platform and the spring. The text on the spring should be facing upward.

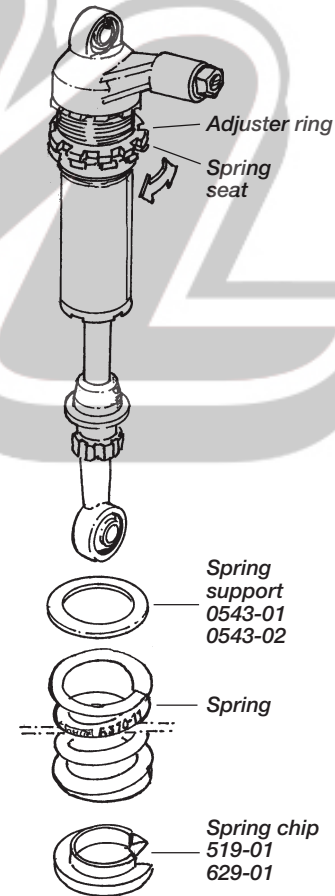

3

Fit the spring clip, turn the shock absorber so the spring rests against the spring seat and turn the rings (upper spring platform and locking nut) so they touch the upper surface of the spring.

4

Turn the upper spring platform approximately 8 laps (10 mm) clockwise to pre-load the spring before fitting the shock absorber to the motorcycle.

5

Fit the shock absorber and measure the free sag with the motorcycle off the ground. (See page 4 for procedures)

6

Let the motorcycle stand on the ground without rider. Fine adjust the pre-load by turning the spring platform until recommended sag is achieved (see Setup data). Measure the spring again and make a note of the pre-load (= free spring length with the length of the compressed spring subtracted).

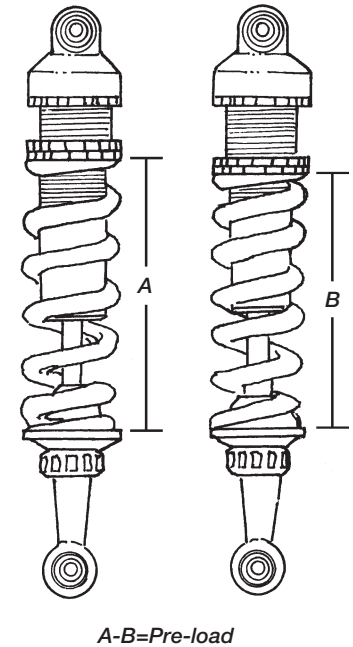

Mounting instructions

1

Put the motorcycle on a stand so the rear wheel has ground clearance. Make sure it's steadily positioned and will not fall over.

⚠ WARNING!

1. It's advisable to have an Öhlins dealer or other qualified person to fit your shock absorber.

2. Instructions in the vehicle service manual are to be followed when changing the shock absorber.

3. When working on a lifted vehicle it must be securely supported to prevent it from falling.

2

Remove the seat by loosening the rear attachment screws.

3

Loosen the rear frame and the hose clamp from the air filter. Disconnect electrical wires. Remove the whole unit with air filter and muffler.

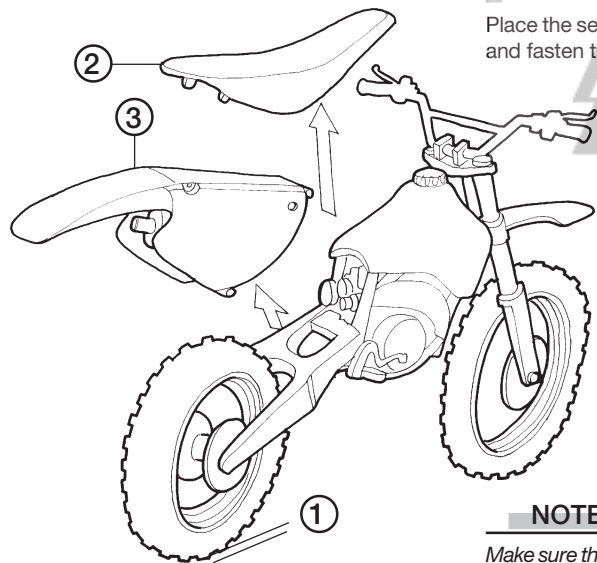

4

Loosen the lower and the upper attachment of the original shock absorber and remove it.

5

Fit the Öhlins shock absorber in the same way as the original unit. Fasten it by using the two original bolts.

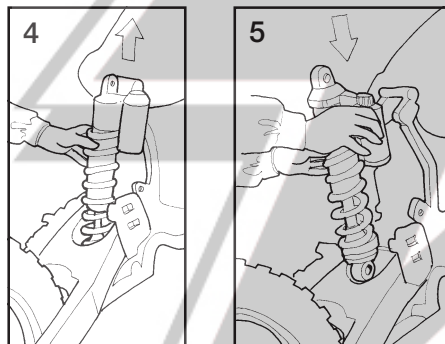

6

Place the seat support and seat back in position and fasten them.

NOTE!

Make sure that all bolts are tightened to the correct torque and that nothing fouls or restricts movement of the shock absorber when the suspension is being fully compressed or extended.

7

Continue your work according to the Owners Manual, section Adjustments.

Spring guideline Moto-X 2005

Brand	Riders weight Kg/pounds	Shock Absorber		Rear	Rear	Front	Front
		Spring Part.No.	Spring rate N/mm	Recom. Static sag	Recom. Ride height	Recom. Static sag	Recom. Ride height
Suzuki RM 125	65/143	596-07	46	30±5 mm	100±5 mm	30±5 mm	80±5 mm
	70/154	596-08	48				
	75/165	596-09	50				
	80/176	596-10	52				
	85/187	596-11	54				
Suzuki RM-Z 250	65/143	596-07	46	30±5 mm	100±5 mm	30±5 mm	80±5 mm
	70/154	596-08	48				
	75/165	596-09	50				
	80/176	596-10	52				
	85/187	596-11	54				
	90/198	596-12	56				
Suzuki RM 250	65/143	596-06	44	30±5 mm	100±5 mm	30±5 mm	80±5 mm
	70/154	596-07	46				
	75/165	596-08	48				
	80/176	596-09	50				
	85/187	596-10	52				
	90/198	596-11	54				