

Adjustments

⚠ Warning!

Before riding, always make sure that the basic settings made by Öhlins are according to recommended Set-up Data. Read about adjustments and setting up in the Öhlins Owner's Manual before you make any adjustments. Contact an Öhlins dealer if you have any questions about setting up the shock absorber.

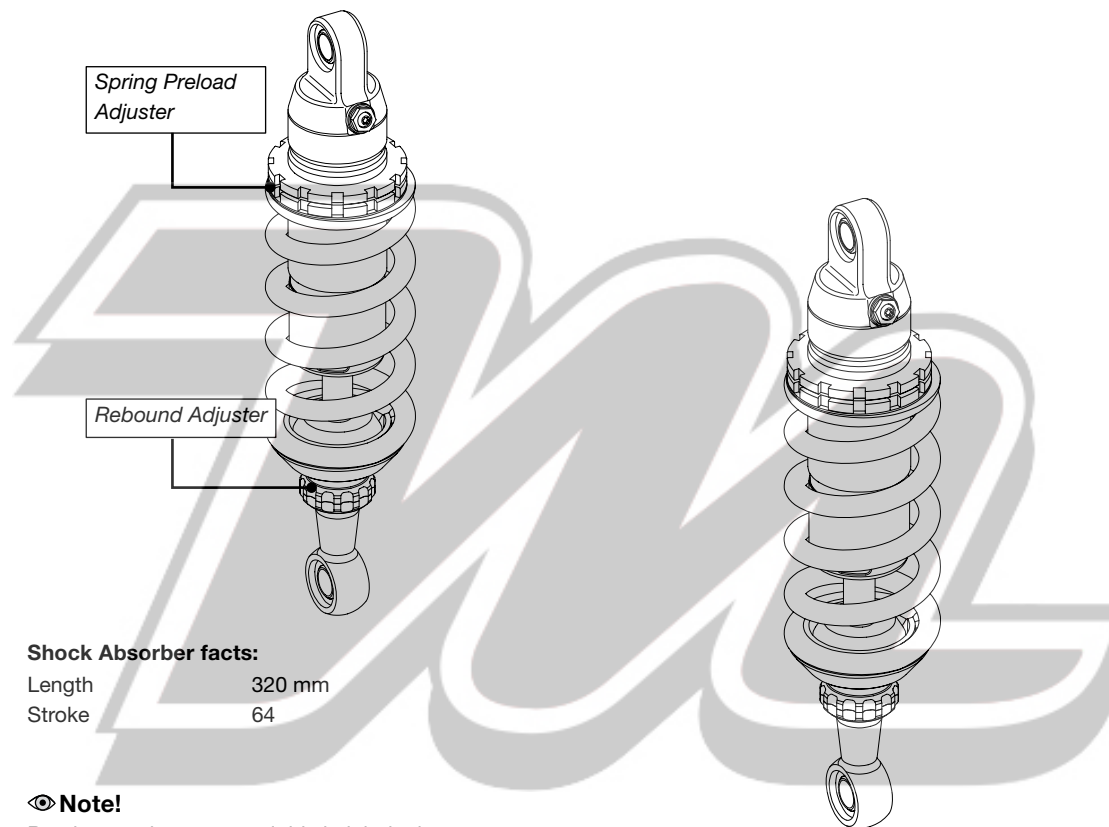

Before installing this product, check the contents of the kit. If anything is missing, please contact your nearest Öhlins dealer.

Kit Contents	Part No.	Pcs.
Shock absorber	SU 045	1
Öhlins Sticker	00192-01	2
C-spanner	00710-02	1
Memo Notes Sticker	01180-01	1
Owner's Manual	07241-02	1

Please note that during storage and transportation, especially at high ambient temperature, some of the oil and grease used for assembling may leak and stain the packaging. This is in no way detrimental to the product, wipe off the excessive oil/grease with a cloth.

⚠ Warning!

Before installing this product, read the Öhlins Owner's Manual. The shock absorber is an important part of your vehicle and may affect the stability of your vehicle.

Set-up Data

Recommended setting

Rebound	16 clicks
Spring Preload	17 mm

Spring

Part No.	Rate
01092-49	130 N/mm
Free spring length	170 mm

Shock Absorber facts:

Length	320 mm
Stroke	64

👁 Note!

Read more about sag and ride height in the Öhlins Owner's Manual.

👁 Öhlins products are subject to continuous improvement and development, therefore, although these instructions include the most up-to-date information available at the time of printing, minor updates may occur.

To find the latest information contact your Öhlins distributor. Please consult your Öhlins dealer if you have any questions regarding the contents in this document.

Part no. SU 045_0
Issued 2011-01-24



Shock Absorber for Suzuki Bandit GSX 1250 F SU 045

Mounting Instructions

© Öhlins Racing AB. All rights reserved. Any reprinting or unauthorized use without the written permission of Öhlins Racing AB is prohibited.

Öhlins Racing AB
Box 722
S-194 27 Upplands Väsby, Sweden
Phone +46 8 590 025 00
fax +46 8 590 025 80



www.ohlins.com



⚠ Warning!

It is advisable to have an Öhlins dealer install the shock absorber.

👁 Note!

When installing, consult your Vehicle Service Manual.

👁 Note!

Before installing the Öhlins shock absorber clean the vehicle thoroughly.

1

Put the motorcycle on a workstand so that the rear wheel barely touches the ground.

⚠ Warning!

Make sure the vehicle is securely supported so that it will not tip.

2

Remove the left side fairing and the left side foot peg.

3

Loosen the upper and the front attachment of the link, (see figure). Remove the lower attachment of the original shock absorber, and remove the whole link arm unit as indicated in the figure.

4

Remove the upper attachment, and remove the original shock absorber.

5

Install the Öhlins shock absorber, reinstall the link arms and the link, fasten the upper and lower attachments of the Öhlins shock absorber, do not tighten yet.

👁 Note!

Lower the motorcycle so that the shock absorber is slightly compressed, before tightening the screws.

6

Tighten all screws to the torque specified in your Suzuki service manual.

7

Reinstall the left side fairing and foot peg.

8

Make sure that all removed parts are reinstalled in the same way as they were before the installation.

👁 Caution!

Make sure that all screws are tightened to the correct torque and that nothing fouls or restricts movement of the shock absorber when the suspension is fully compressed or extended.

