

9

Let the hose follow the lower rear frame and attach the reservoir to the left lifting handle of the rear frame of the motorcycle. Use mounting rubbers and hose clamps.

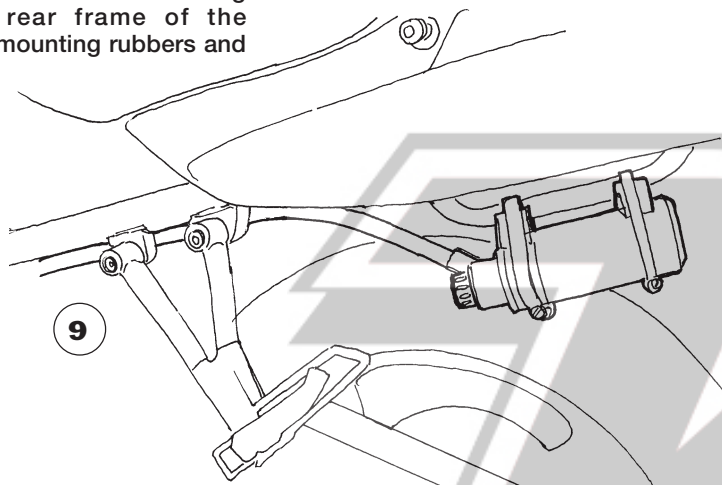

10

Reinstall the right foot rest bracket and the side cover plates.

11

Continue your work according to the Owners Manual, section adjustments.

NOTE!

When disassembling suspension components it's always easier **first** to loosen all bolts and brackets before removing the components. Reversed order when assembling, tightening all bolts is the **last** thing you should do.

⚠ WARNING!

Certain modifications may be necessary when installing the Öhlins shock absorber/suspension. It is essential that the mounting instructions are carefully followed.

Traction, handling,
comfort and safety



ADVANCED SUSPENSION TECHNOLOGY

Öhlins Racing AB, Box 722, S-194 27 Upplands Väsby, Sweden.

Phone +46 8 590 025 00, fax +46 8 590 025 80.

E-mail: info@ohlins.se

SU005 Issued 00 04 10

Mounting instructions

SU 005 - SUZUKI GSF 600 S BANDIT

Kit content

Shock absorber 46 HRC	SU 005	2
Sticker Öhlins	00192-01	2
Mounting rubber	00230-01	2
Hose clamp	00643-02	2
Ty-rap	00231-01	2
Sticker Memo notes	01184-01	1
C-spanner	00710-01	1
Owners Manual		1

Set-up data

Length	319 mm
Stroke	55 mm
Rebound adjustment	16 clicks
Compression adjustment	12 clicks
Preload	16 mm

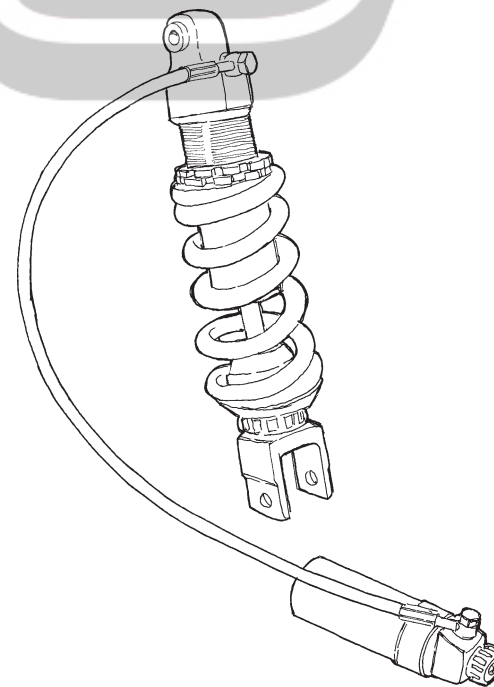

ADVANCED SUSPENSION TECHNOLOGY

Safety signals

Important information concerning safety is distinguished in this manual by the following notations.



The Safety alert symbol means: **Caution! Your safety is involved.**

WARNING!

Failure to follow warning instructions could result in **severe or fatal injury** to anyone working with, inspecting or using the suspension, or to bystanders.

CAUTION!

Caution indicates that special precautions must be taken to avoid damage to the suspension.

NOTE!

This indicates information that is of importance with regard to procedures.

Kit contents

Before installing the shock absorber, please check the contents of the kit, listed on the front page of this instruction. If anything is missing, contact your Öhlins dealer.

NOTE!

During storage and transportation, especially at high ambient temperature, the oil and grease used for assembling may run out inside the packing and damage the expanded polystyrene packing material. This is not unusual and is in no way detrimental to the shock absorber.

Before you start

WARNING!

Installing a shock absorber, that is not approved by the vehicle manufacturer, may affect the stability of your vehicle. Öhlins Racing AB cannot be held responsible for any personal injury or damage whatsoever that may occur after fitting the shock absorber. Contact an Öhlins dealer or other qualified person for advice.

Öhlins Racing AB can not be held responsible for any damage whatsoever to shock absorber or vehicle, or injury to persons, if the instructions for fitting and maintenance are not followed exactly. Similarly, the warranty will become null and void if the instructions are not adhered to.

WARNING!

Please study and make certain that you fully understand all the mounting instructions and the owner's manuals before handling this shock absorber kit. If you have any questions regarding proper installation procedures, contact an Öhlins dealer or other qualified person.

WARNING!

The vehicle service manual must be referred to when installing the Öhlins shock absorber.

NOTE!

Öhlins products are subject to continual improvement and development. Consequently, although these instructions include the most up-to-date information available at the time of printing, there may be minor differences between your suspension and this manual. Please consult your Öhlins dealer if you have any questions with regard to the contents of the manual.

Mounting instructions

1

Put the motorcycle on a stand so the rear wheel is clear of the ground. Make sure it's steadily fixed so it will not fall over.

WARNING!

1. It's advisable to have an Öhlins dealer or other qualified person to fit your shock absorber.

2. Instructions in the vehicle service manual are to be followed when changing the shock absorber.

3. When working on a lifted vehicle it must be securely supported to prevent it from falling.

2

Remove small side cover left side of the motorcycle.

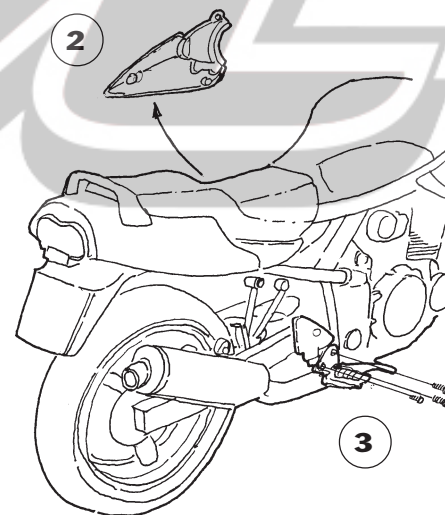

3

Remove the three screws to the foot rest bracket at the right side and let the bracket hang loose.

4

Loosen all the bolts holding the shock absorber and triangle linkage.

5

Remove the lower shock absorber bolts, the bolts holding the pull rods and the triangle link bolts and remove the triangle link downwards.

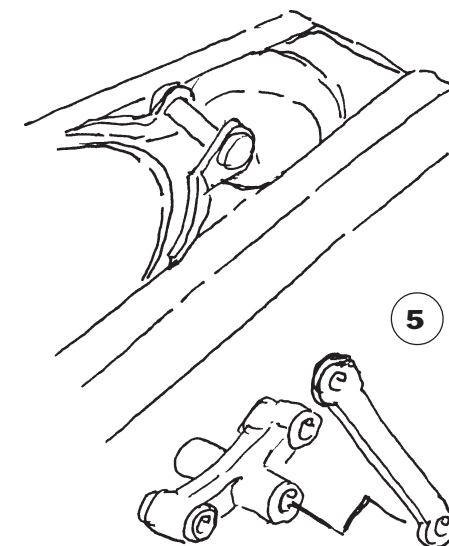

6

Remove the upper shock absorber bolt and lift the shock absorber out downwards.

7

Fit the Öhlins shock absorber in the same position as the standard shock absorber. The hose connection must face the rear wheel.

8

Fit the shock absorber first to the upper bracket and then reassemble the triangle link and pull rods.

NOTE!

Make sure that all bolts are tightened to the correct torque and that nothing fouls or restricts movement of the shock absorber when the suspension is being fully compressed or extended.

© Öhlins Racing AB.
All rights reserved.

Any reprinting or unauthorized use without the written permission of Öhlins Racing AB is prohibited.
Printed in Sweden.