

## Adjustments

### ⚠ Warning!

Before riding, always make sure that the basic settings made by Öhlins are according to recommended Set-up Data. Read about adjustments and setting up in the Öhlins Owner's Manual before you make any adjustments. Contact an Öhlins dealer if you have any questions about setting up the shock absorber.

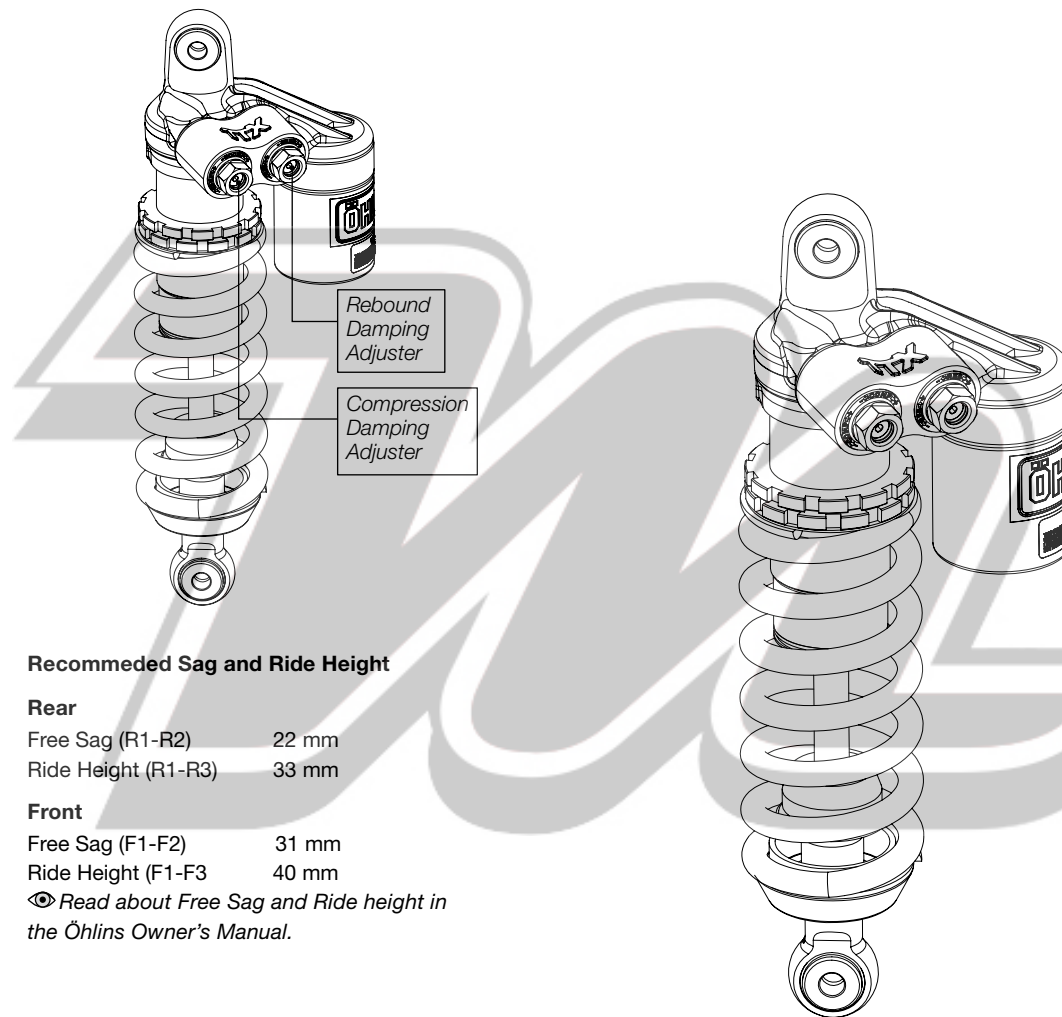

## Set-up Data

### Recommended set-up

Spring Preload	8 mm
Compression	12 clicks
Rebound	12 clicks

### Spring

Part No.	Rate
21042-18	68 N/mm
Free spring length	170 <sup>0</sup> / <sub>-3</sub> mm

### Shock Absorber Data

Length	325,5 mm
Stroke	77 mm

### Recommended Sag and Ride Height

#### Rear

Free Sag (R1-R2)	22 mm
Ride Height (R1-R3)	33 mm

#### Front

Free Sag (F1-F2)	31 mm
Ride Height (F1-F3)	40 mm

👁 Read about Free Sag and Ride height in the Öhlins Owner's Manual.

Before installing this product, check the contents of the kit. If anything is missing, please contact an Öhlins dealer.

### Kit Contents

	Part No.	Pcs.
Shock abs.	MV 931	1
Öhlins Sticker	00192-01	2
C-Spanner	00710-05	1
Memo Notes Sticker	01180-01	1
Owner's Manual	07242-01	1

Please note that during storage and transportation, especially at high ambient temperature, some of the oil and grease used for assembling may leak and stain the packaging. This is in no way detrimental to the product, wipe off the excessive oil/grease with a cloth.

### ⚠ Warning!

Before installing this product, read the Öhlins Owner's Manual. The shock absorber is an important part of your vehicle and may affect the stability of your vehicle.

👁 Öhlins products are subject to continuous improvement and development, therefore, although these instructions include the most up-to-date information available at the time of printing, minor updates may occur.

To find the latest information contact your Öhlins distributor. Please consult your Öhlins dealer if you have any questions regarding the contents in this document.

Part no. MV\_931\_0  
Issued 2011-11-21



## Shock Absorber for MV Agusta F4 MV 931

### Mounting Instructions

© Öhlins Racing AB. All rights reserved. Any reprinting or unauthorized use without the written permission of Öhlins Racing AB is prohibited.

Öhlins Racing AB  
Box 722  
S-194 27 Upplands Väsby, Sweden  
Phone +46 8 590 025 00  
fax +46 8 590 025 80



[www.ohlins.com](http://www.ohlins.com)



**⚠ Warning!**

*It is advisable to have an Öhlins dealer install the shock absorber.*

*When installing, consult your Vehicle Service Manual.*

**1**

Put the motorcycle on a workstand so that the rear wheel barely touches the ground.

**⚠ Warning!**

*Make sure the vehicle is securely supported so that it will not tip.*

**2**

Loosen the push rod from the rear swing arm.

**3**

Loosen the lower shock absorber mounting bolt.

**4**

Remove the upper shock absorber mounting bolt and remove the original shock absorber.

**👁 Note!**

*Before installing the Öhlins shock absorber clean the vehicle thoroughly.*

**5**

Install the Öhlins shock absorber in reversed order, do not tighten the fitting bolts yet.

**👁 Note!**

*Lower the motorcycle so that the shock absorber is slightly compressed, before tightening the fitting bolts.*

**6**

Tighten the upper and lower bolts.

**7**

Make sure that all removed parts are reinstalled in the same way as they were before the installation of the Öhlins shock absorber.

**👉 Caution!**

*Make sure that all bolts are tightened to the correct torque and that nothing fouls or restricts movement of the shock absorber when the suspension is fully compressed or extended.*