

Mounting Instructions

WITH SET-UP DATA

SHOCK ABSORBER MV 788 for MV F4

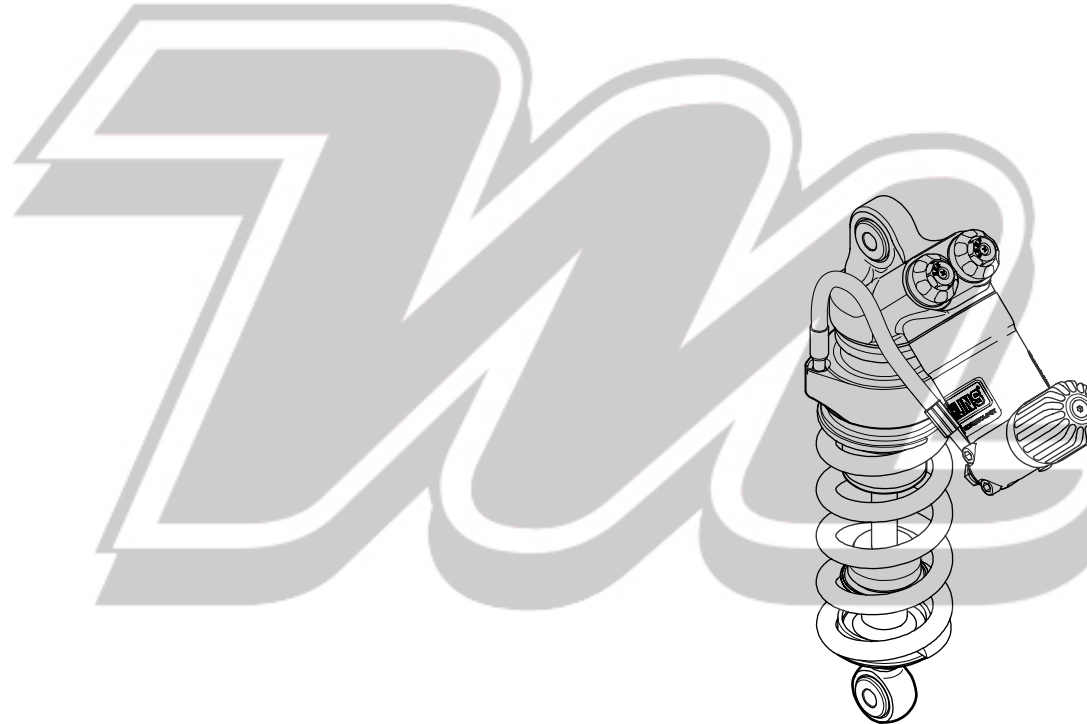

Before installing this shock absorber, check the contents of the kit listed below. If anything is missing, please contact your nearest Öhlins dealer.

Kit Contents:

	Part no.	Pcs.
Shock absorber	MV 788	1
Öhlins Sticker	00192-01	2
Memo Note Sticker	01180-01	1
Owner's Manual	07242-01	1

During storage and transportation, especially at high ambient temperature, some of the oil and grease used for assembling may leak and stain the packaging. This is in no way detrimental to the product, wipe off the excessive oil/grease with a cloth.

Set-up Data

Spring preload	14 mm
Compression damping	12 clicks
Rebound damping	12 clicks
Shock absorber length	304,5 mm
Stroke	70 mm

Before installing this product, read the Öhlins Owner's Manual!

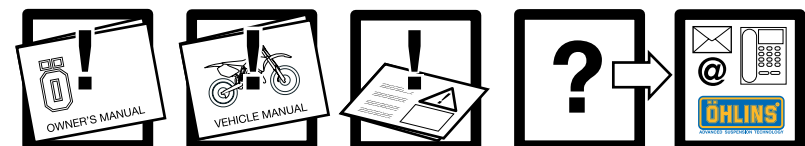

Öhlins Racing AB, Box 722, S-194 27 Upplands Väsby, Sweden.
Phone +46 8 590 025 00 Fax +46 8 590 025 80
www.ohlins.com

© Öhlins Racing AB. All rights reserved. Any reprinting or unauthorized use without the written permission of Öhlins Racing AB is prohibited.
Printed in Sweden.



Mounting Instructions MV788_2 Issued 2008 09 02
These instructions and other documents can be downloaded from
www.ohlins.com

HOW TO INSTALL

⚠ WARNING!

It is advisable to have an Öhlins dealer install the shock absorber.

1

Put the motorcycle on a workstand so that the rear wheel barely touches the ground.

⚠ WARNING!

Make sure the vehicle is securely supported so that it will not tip.

2

Remove the original shock absorber. Consult your Vehicle Service Manual.

NOTE!

Recommendation: Before installing the Öhlins shock absorber clean the vehicle thoroughly.

3

Install the Öhlins shock absorber with the reservoir down as indicated in the figure.

NOTE!

Lower the motorcycle so that the shock absorber is slightly compressed, before tightening the screws.

Make sure that all screws are tightened to the correct torque and that nothing fouls or restricts movement of the shock absorber when the suspension is fully compressed or extended.

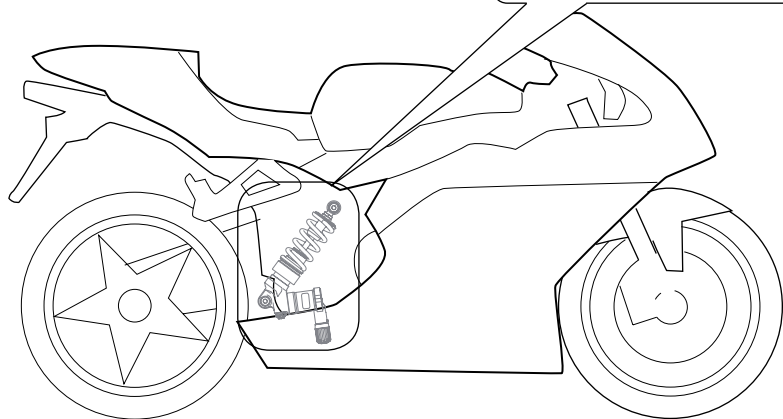
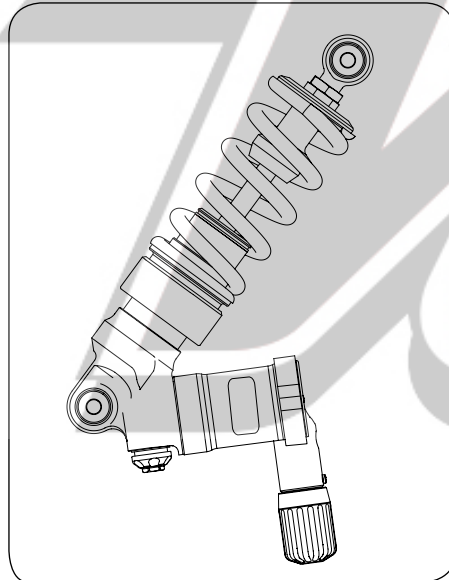

ADJUSTMENTS

Always ensure that the basic settings made by Öhlins are intact.

1 Spring preload

Turn the Hydraulic Adjuster knob to set the spring preload. Turn clockwise to increase the preload, turn counter clockwise to decrease.

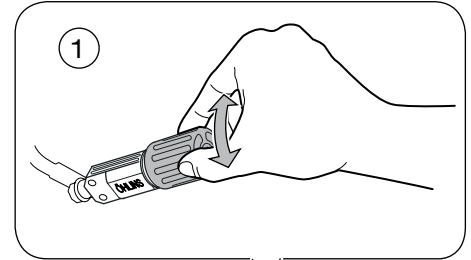

2 Compression

Adjust by turning the knob labelled "COMP" on the cylinder head. Or, use a 14 mm socket T-bar and turn the hexagon nut on the adjuster knob. Turn clockwise to increase damping, turn counter clockwise to decrease.

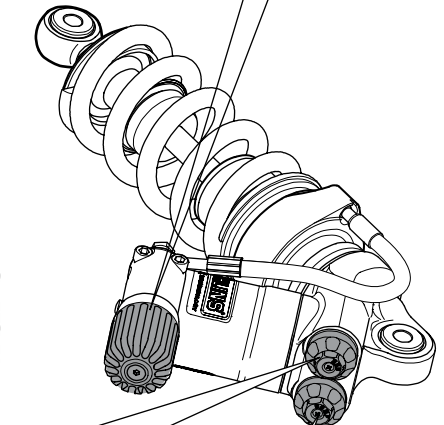

3 Rebound

Adjust by turning the knob labelled "REB" on the cylinder head. Or, use a 14 mm socket T-bar and turn the hexagon nut on the adjuster knob. Turn clockwise to increase damping, turn counter clockwise to decrease.

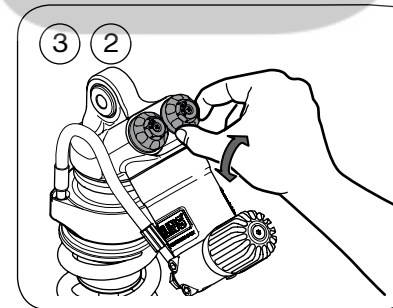

NOTE!

When delivered the Öhlins shock absorber is dialed to recommended settings for the specific brand and make of the vehicle. If you have changed the setting, reset according to the set-up data in the Mounting Instruction.

To reset: The adjuster has a right hand thread. Turn the adjuster clockwise to fully closed (pos. zero [0]). Turn counter clockwise to open and count the clicks until you reach the recommended number in the Set-up data.

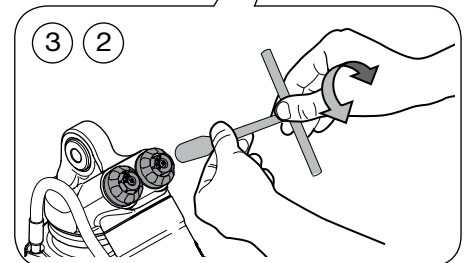

CAUTION!

Do not use force, delicate sealing surfaces can be damaged. Handtighten only.