

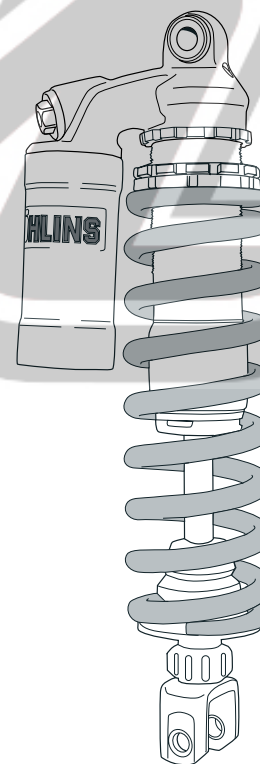

Öhlins Racing AB, Box 722, S-194 27 Upplands Väsby, Sweden.  
Phone +46 8 590 025 00. Fax +46 8 590 025 80.  
[www.ohlins.com](http://www.ohlins.com)

# Mounting Instructions

## Öhlins Shock Absorber KT 694 for KTM 450 SX / 525 SX 2006



### Kit Contents

Before installing this shock absorber, please check the contents of the kit listed below. If any part is missing, please contact your Öhlins dealer.

shock absorber 46PRXQW KT 694	(1)
spring clip	00516-21 (1)
c-spanner	00710-02 (1)
sticker Öhlins	00197-01 (2)
sticker memo notes	01180-01 (1)
owner's manual	(1)

### NOTE!

Spring not included. See the spring guide in this manual.

Öhlins Racing AB cannot be held responsible for any damage to the shock absorber, vehicle or injury to persons, if the instructions for fitting and maintenance are not followed exactly. Similarly, the warranty will become null and void if the instructions are not adhered to.

### In this manual

Safety precautions  
Mounting instructions  
Changing the spring  
Before riding  
Set-up data  
Adjustments  
Spring guide

KT 694 - Issued 2005 12 07

## SAFETY PRECAUTIONS

### Read this manual carefully!

Pay special attention to statements preceded by the following notations:



The Safety alert symbol means: Attention! Your safety is involved!

### WARNING

Failure to follow warning instructions may result in **severe or fatal injury** to anyone working with, inspecting or using this shock absorber, or to bystanders.

### CAUTION!

Caution indicates that special precautions must be taken to avoid damage to the shock absorber.

### NOTE!

Indicates information that is of importance regarding mounting procedures.

### NOTE!

Öhlins products are subject to continuous improvement and development. Therefore, although these instructions include the most up-to-date information available at the time of printing, there may be minor differences between your shock absorber and this manual. Please consult your Öhlins dealer if you have any questions regarding the contents of this manual.

### NOTE!

During storage and transportation, especially at high ambient temperature, the oil and grease used for assembling may run out inside the packing and damage the expanded polystyrene packing material. This is not unusual and is in no way detrimental to the shock absorber.

### WARNING!

1. **Installing a shock absorber, that is not approved by the vehicle manufacturer, may affect the vehicle's stability.** Öhlins Racing AB cannot be held responsible for any personal injury or damage that may occur after fitting the shock absorber. Contact an Öhlins dealer or other qualified person for advice.

2. The **vehicle's service manual must be referred to** when installing this shock absorber.

3. Please study and make certain you fully understand the mounting instructions and the owner's manual before handling this shock absorber. If you have any questions regarding proper installation procedures, contact an Öhlins dealer or other qualified person.



## SPRING GUIDE

Brand	Rider's weight Kg/pounds	Spring Part.no.	Spring rate N/mm
<b>KTM</b> 125 SX	65/143	580-18	68
	70/154	580-19	70
	75/165	580-21	75
	80/176	580-24	80
	85/187	580-26	85
<b>KTM</b> 250 SX	65/143	580-17	66
	70/154	580-18	68
	75/165	580-19	70
	80/176	580-21	75
	85/187	580-24	80
<b>KTM</b> 250 SX-F	90/198	580-26	85
	65/143	580-17	66
	70/154	580-18	68
	75/165	580-19	70
	80/176	580-21	75
<b>KTM</b> 450 SX / 525 SX	85/187	580-24	80
	90/198	580-26	85
	95/209	580-29	90
	70/154	580-19	70
	75/165	580-21	75
	80-176	580-24	80

## ADJUSTMENTS

The Öhlins shock absorber KT 694 features the following adjusters:

### Spring preload adjustment

Turn the rings on the shock absorber body using the C-spanner provided in this kit. Turn clockwise for harder adjustment, turn counter-clockwise to release the preload.

### Compression damping adjustment

Adjustments are made on top of the reservoir. Low speed adjustment: Slotted centre screw. High speed adjustment: Hexagon screw.

### Rebound damping adjustment

Adjust by turning the wheel on the piston shaft above the end bracket.

### NOTE!

When delivered, the Öhlins shock absorber is dialed to recommended settings for the specific brand and make of the motorcycle. If you have changed the setting, reset according to the following description:

Turn adjusters have a normal right hand thread. Turn the damping adjusters clockwise to fully closed (position zero [0]). Turn counter clockwise to open and count the clicks until you reach the recommended number of clicks. See setup data in this manual.

### CAUTION!

Do not use too much force, delicate sealing surfaces can be damaged.

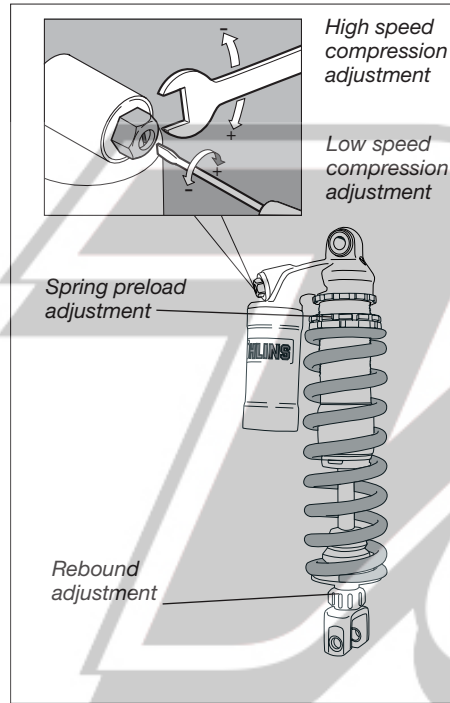

### NOTE!

Read more about compression, rebound and spring pre-load in your Öhlins Owner's manual.

## MOUNTING INSTRUCTIONS

### Step 1 - Assembly of Öhlins Shock Absorber with spring

#### ⚠ WARNING!

1. It is advisable to have an Öhlins dealer or other qualified person to fit the suspension component.
2. Follow the instructions in the vehicle service manual when changing the suspension component.
3. When working on a lifted vehicle make sure it is securely supported to prevent it from falling.

#### 1

Make sure that all components listed on the front page of this manual under "Kit contents" are included.

#### 2

Measure the free length of the spring (A).

#### 3

Fit the spring clip, turn the shock absorber so the spring rests against the spring platform and turn the rings (lock nut and spring platform) so they touch the upper surface of the spring.

### Setting the spring pre-load

With a C-spanner, turn the upper spring platform approximately **4 turns (6 mm)** clockwise to pre-load the spring before fitting the shock absorber to the motorcycle.

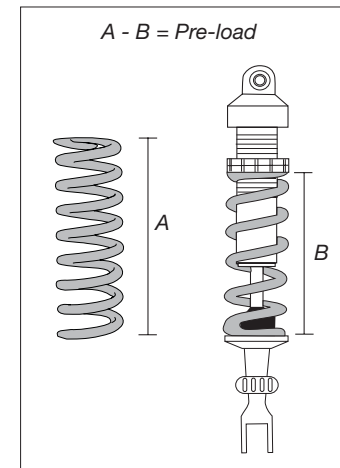
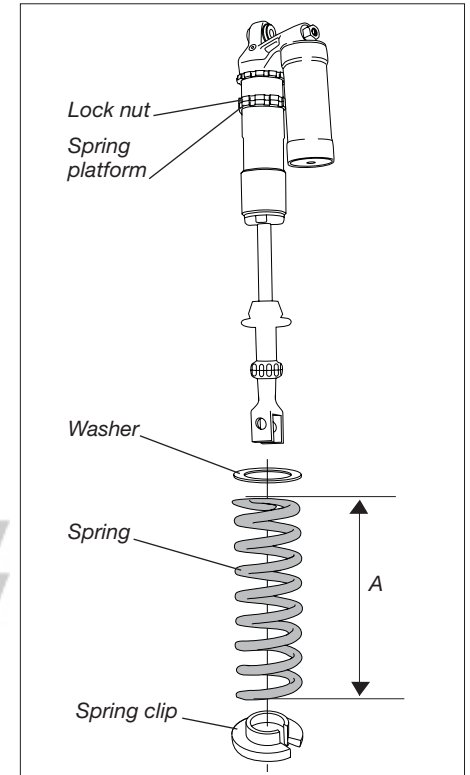

## CHANGING THE SPRING

#### 1

To remove the original spring you must first loosen the spring pre-load by turning the upper spring platform counter clockwise with a C-spanner.

#### 2

Remove the spring clip and then the original spring.

#### 3

Change spring and set the new spring pre-load according to the section above.

## MOUNTING INSTRUCTIONS

### Step 2 - Installing the shock absorber

#### ▲ WARNING!

1. It is advisable to have an Öhlins dealer or other qualified person to fit the suspension component.
2. Follow the instructions in the vehicle service manual when changing the suspension component.
3. When working on a lifted vehicle make sure it is securely supported to prevent it from falling.

1

Put the motorcycle on a workstand to raise the rear wheel off the ground. Make sure the vehicle is secure so it will not fall over.

2

Loosen the lower and the upper attachment of the original shock absorber. Remove it backwards and out to the right, above the right swing.

3

Fit the Öhlins shock absorber in the same way as the original unit. Fasten it by using the two original bolts.

#### NOTE!

Put the motorcycle back on the floor before tightening the bolts. Make sure the vehicle is secure and will not fall over. You may need an assistant for this.

#### NOTE!

Make sure that all bolts are tightened to the correct torque and that nothing fouls or restricts movement of the shock absorber when the suspension is being fully compressed or extended.

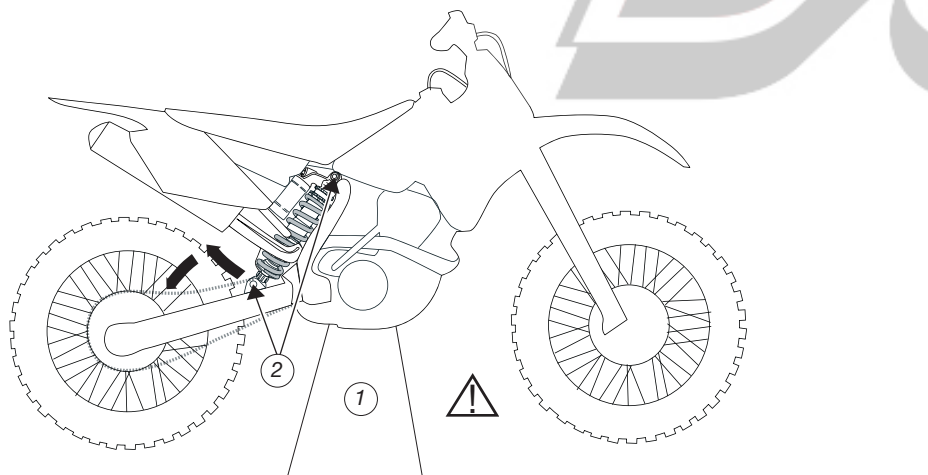

## BEFORE RIDING

### IMPORTANT NOTICE!

Before riding your bike, check sag and ride height according to your Öhlins Owner's manual.

To get the most out of your suspension component it is of great importance to make proper settings and to use the correct spring for your weight - **full riding equipment on!**

We recommend you to read your Öhlins Owner's manual carefully to understand the different effects of the different settings.

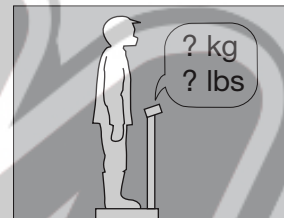
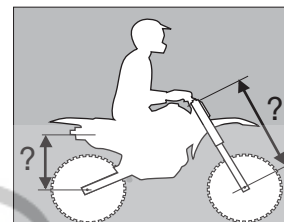

## SET-UP DATA

#### NOTE!

Read more about compression and rebound in your Öhlins Owner's manual.

#### NOTE!

If your measured sag and ride height differ from this set-up data, change the preload according to the section "Adjustments" in this manual.

If, after changing the preload, ride height is still higher than recommended, softer spring/springs must be used. If ride height is lower than recommended, harder spring/springs must be used. Contact your Öhlins dealer for advice.

Rebound adjustment	22 clicks
Low speed compression	15 clicks
High speed compression	1.5 turns

Free sag, rear	35 ± 5 mm
Free sag, front	30 ± 5 mm
Ride height, rear	110 - 115 mm
Ride height, front	80 ± 5 mm

Shock absorber length	405 mm
Stroke	104 mm