

Mounting Instructions

Öhlins shock absorber kit KT 594
for KTM SX 450R and SX 525R 2005

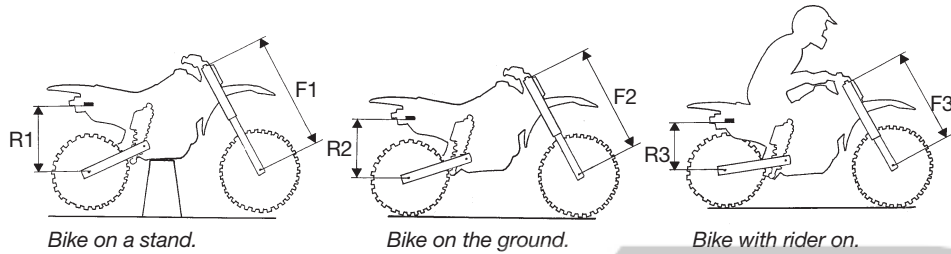

Setup data

Length	404.5 mm
Stroke	105 mm
Rebound adjustment	20 clicks
Compression adjustment	15 clicks
High speed comp. adj	2 turns
Free sag, rear	35±5 mm
Free sag, front	30±5 mm
Ride height, rear	100±5 mm
Ride height, front	80±5 mm
Front fork adjustment	std.
Recommended fork springs	std.

Checking sag and ride height

Front suspension

F1. Bike on a stand with the suspension fully extended =

F2. Bike on the ground without rider =

F3. Bike on the ground with rider =

Free sag F1 - F2 =

Ride height F1 - F3 =

Rear suspension

R1. Bike on a stand with the suspension fully extended =

R2. Bike on the ground without rider =

R3. Bike on the ground with rider =

Free sag R1 - R2 =

Ride height R1 - R3 =

NOTE!

*If ride height is higher than recommended, softer spring/springs must be used.
If ride height is lower than recommended, harder spring/springs must be used.
Contact your Öhlins dealer for advice.*

NOTE!

Make notes when the correct spring is mounted and sag and ride height is adjusted.

Spring pre-load _____ mm

Notes

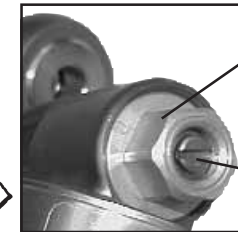
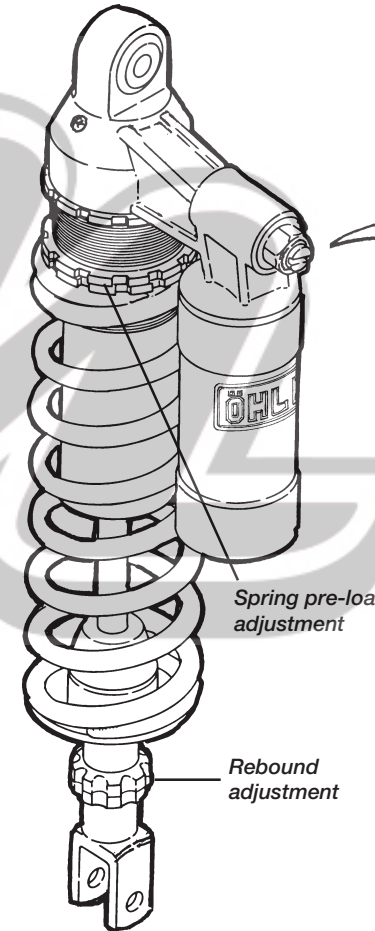

High speed compression adjustment

Low speed compression adjustment

Öhlins shock absorber 46 PRXQ

Your Öhlins shock absorber type 46 PRXQ features the following adjusters:

Compression damping adjuster

Adjustments are made on top of the reservoir.
Low speed adjustments: Slotted centre screw.
High speed adjustments: Hexagon screw.

Rebound damping adjuster

Adjuster wheel on the piston shaft above the end bracket.

Spring pre-load adjuster

Adjustment made by rings on cylinder house.
Use C-spanner.

NOTE!

When delivered the Öhlins shock absorber is dialed to recommended settings for the specific brand and make of the motorcycle. If you have changed the settings, check like this:

The adjusters have a normal right hand thread. Turn the damping adjusters clockwise to fully closed (pos. zero [0]). Turn counter clockwise to open and count the clicks until you reach the recommended number of clicks. See Setup data at last page.

CAUTION!

Do not use too much force, delicate sealing surfaces can be damaged.



Öhlins Racing AB, Box 722, S-194 27 Upplands Väsby, Sweden.
Phone +46 8 590 025 00. Fax +46 8 590 025 80.
www.ohlins.com

KT 594, issued 05 04 05

© Öhlins Racing AB. All rights reserved. Any reprinting or unauthorized use without the written permission of Öhlins Racing AB is prohibited. Printed in Sweden.



Notes

Assembly of Öhlins Shock Absorber with spring separately supplied

1

Make sure that all components are included; spring, spring clip and washer. Measure the free length of the spring.

2

Place the washer between the upper spring platform and the spring. The text on the spring should be facing upward.

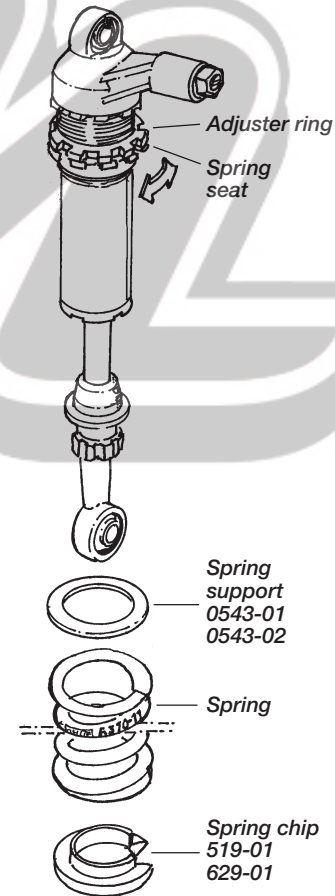

3

Fit the spring clip, turn the shock absorber so the spring rests against the spring seat and turn the rings (upper spring platform and locking nut) so they touch the upper surface of the spring.

4

Turn the upper spring platform approximately 8 laps (10 mm) clockwise to pre-load the spring before fitting the shock absorber to the motorcycle.

5

Fit the shock absorber and measure the free sag with the motorcycle off the ground. (See page 4 for procedures)

6

Let the motorcycle stand on the ground without rider. Fine adjust the pre-load by turning the spring platform until recommended sag is achieved (see Setup data). Measure the spring again and make a note of the pre-load (= free spring length with the length of the compressed spring subtracted).

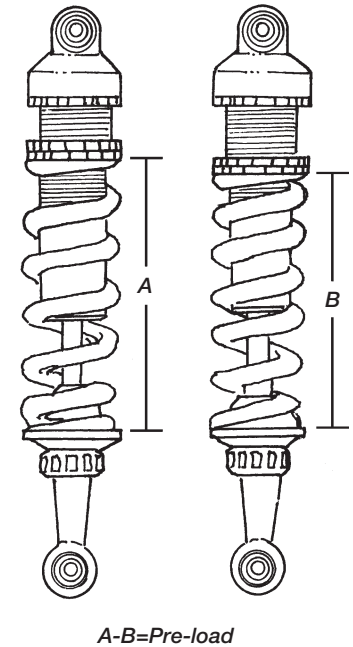

Mounting instructions

1

Put the motorcycle on a stand so the rear wheel has ground clearance. Make sure it's steadily positioned and will not fall over.

⚠ WARNING!

1. It's advisable to have an Öhlins dealer or other qualified person to fit your shock absorber.

2. Instructions in the vehicle service manual are to be followed when changing the shock absorber.

3. When working on a lifted vehicle it must be securely supported to prevent it from falling.

2

Loosen the lower and the upper attachment of the original shock absorber and remove it. Backwards and out to the right above the right swing.

3

Fit the Öhlins shock absorber in the same way as the original unit. Fasten it by using the two original bolts.

4

Continue your work according to the Owners Manual, section Adjustments

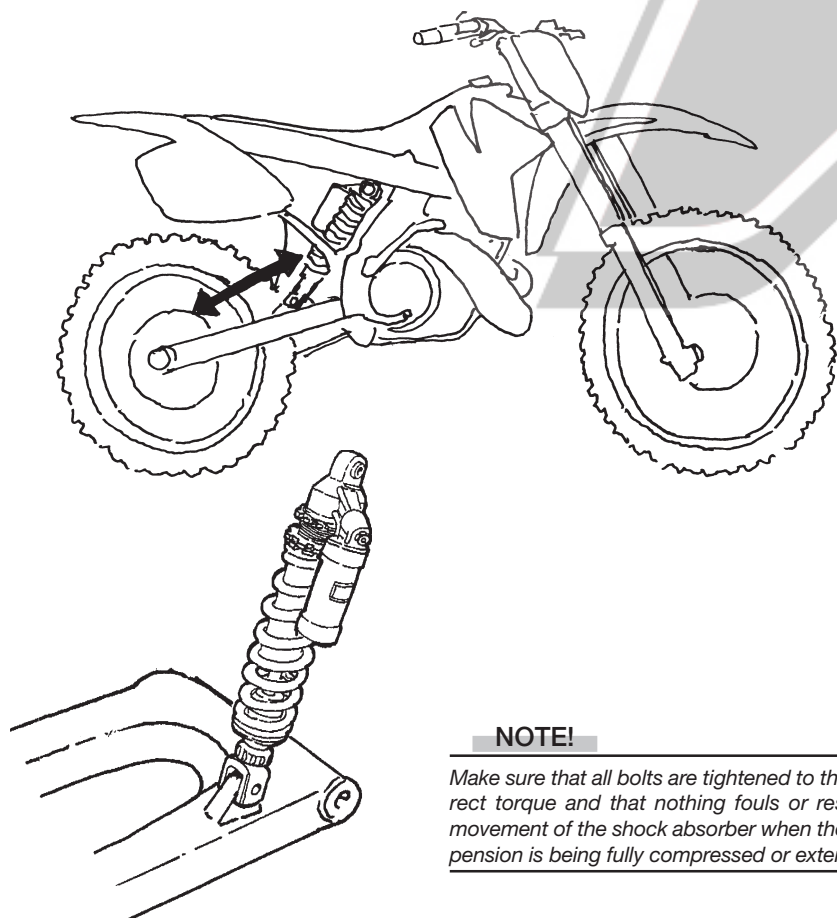

NOTE!

Make sure that all bolts are tightened to the correct torque and that nothing fouls or restricts movement of the shock absorber when the suspension is being fully compressed or extended.

Spring guideline Moto-X 2005

Brand	Riders weight Kg/pounds	Shock Absorber		Rear	Rear	Front	Front
		Spring Part.No.	Spring rate N/mm	Recom. Static sag	Recom. Ride height	Recom. Static sag	Recom. Ride height
KTM SX 85	35/77	698-01	34	25±5 mm	70±5 mm	25±5 mm	60±5 mm
	40/88	698-02	36				
	45/99	698-03	38				
	50/110	698-04	40				
	55/121	698-05	42				
KTM SX 125	60/132	580-18	68	35±5 mm	100±5 mm	30±5 mm	80±5 mm
	65/143	580-19	70				
	70/154	580-21	75				
	75/165	580-24	80				
	80/176	580-26	85				
KTM SX 250	85/187	580-29	90				
	65/143	580-18	68	35±5 mm	100±5 mm	30±5 mm	80±5 mm
	70/154	580-19	70				
	75/165	580-21	75				
	80/176	580-24	80				
KTM SX 450R/525R	85/187	580-26	85				
	90/198	580-29	90				
	95/209	580-31	95				
	70/154	580-19	70	35±5 mm	100±5 mm	30±5 mm	80±5 mm
	75/165	580-21	75				
KTM SX 450R/525R	80-176	580-24	80				
	85/187	580-26	85				
	90/198	580-29	90				
	95/209	580-31	95				
	50 mm Shock Absorber						
KTM SX 450R/525R	70/154		70	35±5 mm	100±5 mm	30±5 mm	80±5 mm
	75/165		75				
	80/176	6320-24	80				
9 mm pre-load	85/187	6320-26	85				
	90/198	6320-29	90				
	95/209	6320-31	95				