

⚠ Warning!

Do not use the shock absorber in combination with longer swing arms and/or larger wheels.

👁 Note!

Please note that this image is a general representation of the product and may differ slightly from your product.

Kit Contents

Description	Part No	Pcs
Shock absorber	KT1398	1
Spring clip	00116-03	1
C-spanner	00710-01	1
Sticker Öhlins	10207-01	1
Owner's manual	07251-02	1

👁 Note!

Please note that during storage and transportation, especially at high ambient temperature, some of the oil and grease used for assembling may leak and stain the packaging. This is in no way detrimental to the product, wipe off the excessive oil/grease with a cloth.

👁 Note!

Before installing this product, check the contents of the kit. If anything is missing, please contact an Öhlins dealer.

⚠ Warning!

Before installing this product, read the Öhlins Owner's Manual. The shock absorber/front fork/steering damper is an important part of your vehicle and will affect the stability.

Shock absorber for KTM 65SX

KT 1398

Mounting Instructions

MOUNTING INSTRUCTIONS

Spring recommendation list

SX65		
Rider's weight kg/pounds	Spring rate N/mm	Spring part no.
< 35/77	35	00181-09
40/88	40	00181-10
> 45/99	45	00181-11

Rider's weight: Rider wearing all riding equipment.

⚠ Warning!

It is advisable to have an Öhlins dealer install the shock absorber/front fork/steering damper.

👁 Note!

When working on this product, always see the Vehicle Service Manual for vehicle specific procedures and important data.

1

Measure the free length of the spring (A).

2

Install the spring clip, turn the shock absorber so that the spring rests against the spring platform and turn the rings (lock nut and spring platform) so they touch the upper surface of the spring.

3

Set the spring preload;

Use a C-spanner. Turn the upper spring platform approximately 2 turns (3 mm) clockwise to preload the spring before installing the shock absorber to the vehicle.

Change the Spring

1

To remove the original spring, you must first release the spring preload by turning the upper spring platform counter clockwise. Use a C-spanner.

2

Remove the spring clip and then the original spring.

3

Change spring and set the new spring preload according to the section above.

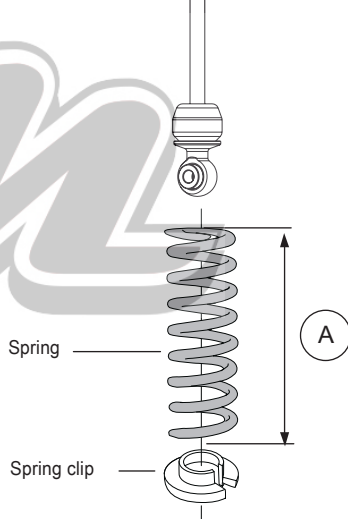
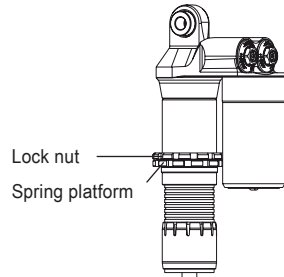

A - B = Spring Preload

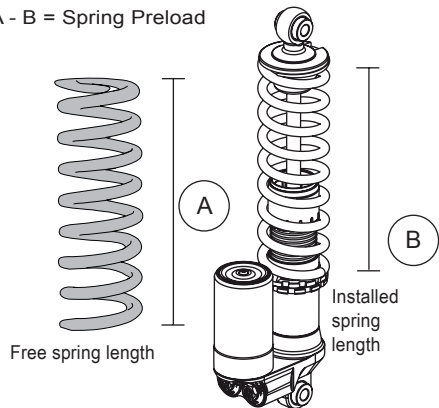

MOUNTING INSTRUCTIONS

⚠ Warning!

It is advisable to have an Öhlins dealer install the shock absorber/front fork/steering damper.

⚠ Warning!

If working on a raised vehicle, ensure it is securely supported so that it will not tip.

👁 Note!

Before mounting this product clean the vehicle.

👁 Note!

When working on this product, always see the Vehicle Service Manual for vehicle specific procedures and important data.

1

Put the motorcycle on a workstand so that the rear wheel barely touches the ground.

2

Loosen the lower and the upper attachment of the original shock absorber. Remove it from the motorcycle.

3

Install the Öhlins shock absorber with the reservoir down, pointing towards the front.

👁 Note!

Lower the vehicle so that the suspension is slightly compressed before tightening the screws.

👁 Note!

Always make sure the adjusters are protected from gravel spray and flying pebbles. Consider protecting with a cover if the adjusters are exposed to gravel spray.

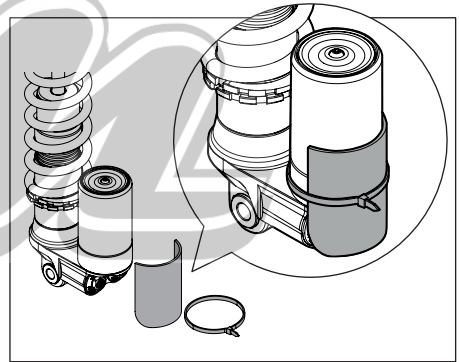

4

Tighten the upper and the lower attachments. Make sure that all removed parts are installed in the same way as they were before the installation.

👁 Caution!

Ensure that all screws are tightened to the correct torque and that nothing fouls or restricts movement of the shock absorber/front fork/steering damper when the suspension is fully compressed or extended.

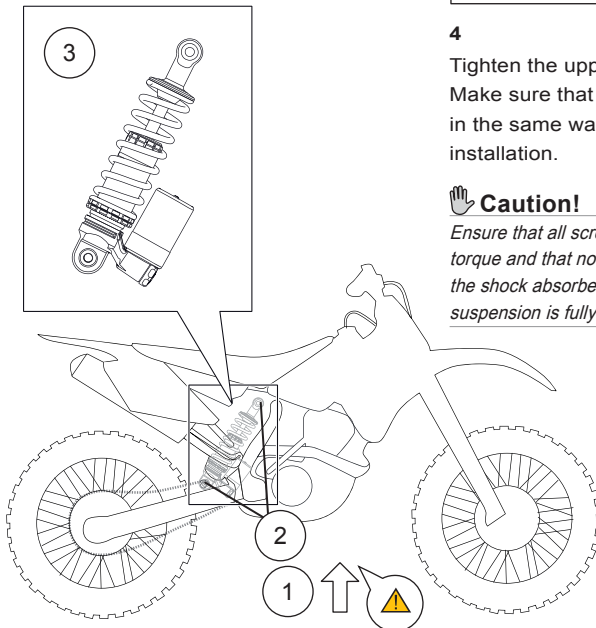

ADJUSTMENTS

⚠ Warning!

Before riding, always make sure that the basic settings made by Öhlins are according to recommended Set-up Data. Read about adjustments and setting up in the Öhlins Owner's Manual before you make any adjustments. Contact an Öhlins dealer if you have any questions about setting up.

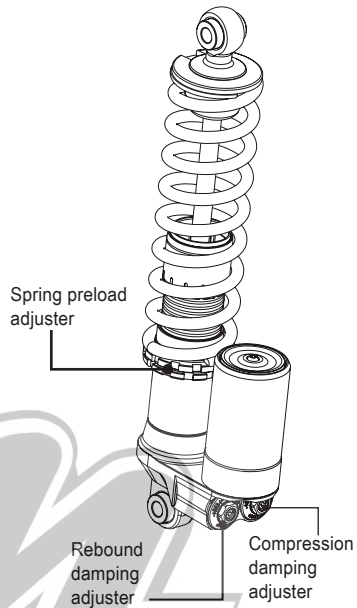

SET-UP DATA

Length	348	mm
Stroke active	103	mm
Rebound	12	clicks
Compression	12	clicks
Spring preload	3	mm
	2	turns
Free sag, rear	20±5	mm

👁 Öhlins products are subject to continuous improvement and development, therefore, although these instructions include the most up-to-date information available at the time of printing, minor updates may occur.

To find the latest information contact an Öhlins distributor. Please contact Öhlins if you have any questions regarding the contents in this document.

Part no. MI_KT1398_0
Issued 2013-05-30



© Öhlins Racing AB. All rights reserved. Any reprinting or unauthorized use without the written permission of Öhlins Racing AB is prohibited.

Öhlins Racing AB
Box 722
S-194 27 Upplands Väsby, Sweden
Phone +46 8 590 025 00
fax +46 8 590 025 80



www.ohlins.com