

## Adjustments

### ⚠ Warning!

Before riding, always make sure that the basic settings made by Öhlins are according to recommended Set-up Data. Read about adjustments and setting up in the Öhlins Owner's Manual before you make any adjustments. Contact an Öhlins dealer if you have any questions about setting up the shock absorber.

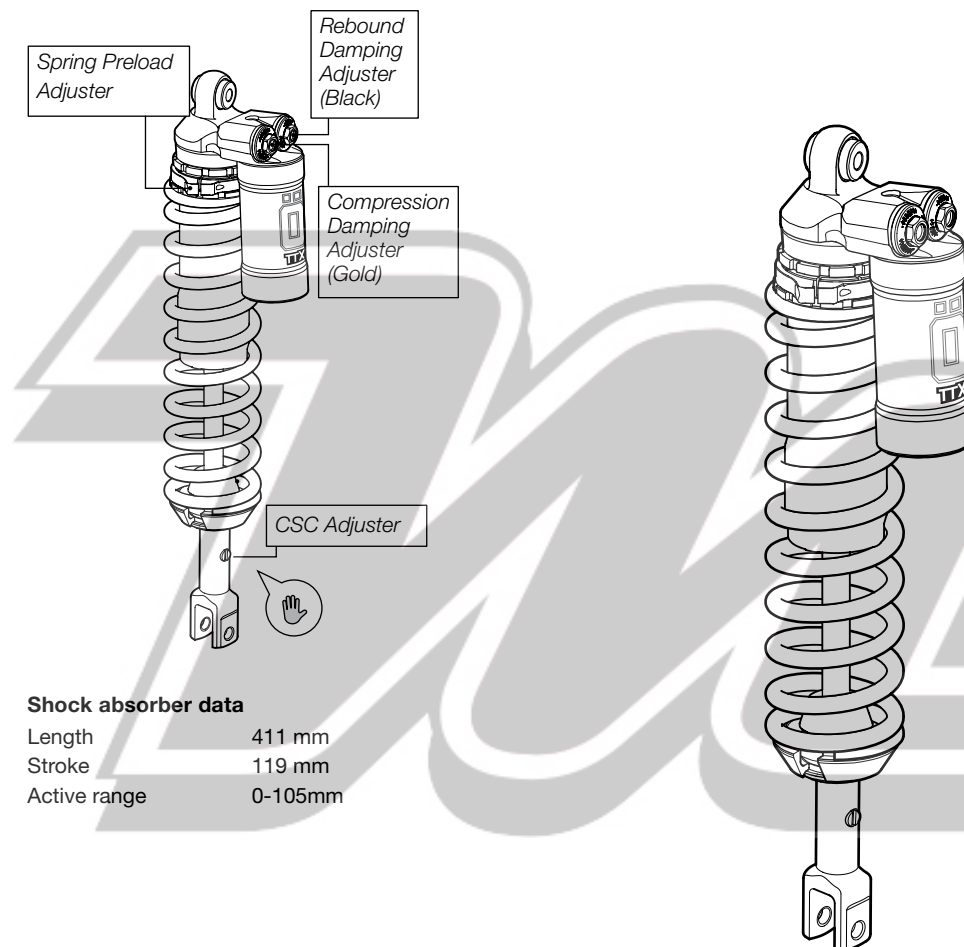

## Set-up Data

### Recommended set-up

Spring preload	6 mm (3 turns)
Rebound damping	10 clicks
Compression damping	12 clicks
CSC damping	24 clicks

### Free sag and Ride height

Free sag (R1-R2)	35 ± 5 mm
Ride height (R1-R3)	110 ± 5 mm

👁 Read more about free sag and ride height in the Öhlins Owner's Manual.

### Shock absorber data

Length	411 mm
Stroke	119 mm
Active range	0-105mm

👁 Öhlins products are subject to continuous improvement and development, therefore, although these instructions include the most up-to-date information available at the time of printing, minor updates may occur.

To find the latest information contact your Öhlins distributor. Please consult your Öhlins dealer if you have any questions regarding the contents in this document.

Part no. KT1184\_0  
Issued 2010-08-19



© Öhlins Racing AB. All rights reserved. Any reprinting or unauthorized use without the written permission of Öhlins Racing AB is prohibited.

Öhlins Racing AB  
Box 722  
S-194 27 Upplands Väsby, Sweden  
Phone +46 8 590 025 00  
fax +46 8 590 025 80



[www.ohlins.com](http://www.ohlins.com)

Before installing this product, check the contents of the kit. If anything is missing, please contact an Öhlins dealer.

### Kit Contents

	Part No.	Pcs.
Shock absorber	KT 1184	1
Spring clip	15629-02	1
C-spanner	00710-02	1
Öhlins Sticker	10207-01	1
Memo Notes Sticker	01180-01	1
Information sheet	01198-01	1
Owner's Manual	07253-01	1

### 👁 Note!

No spring included in this kit. See the Spring Guide in this folder, or contact an Öhlins dealer for advice.

Please note that during storage and transportation, especially at high ambient temperature, some of the oil and grease used for assembling may leak and stain the packaging. This is in no way detrimental to the product, wipe off the excessive oil/grease with a cloth.

### ⚠ Warning!

Before installing this product, read the Öhlins Owner's Manual. The shock absorber is an important part of your vehicle and will affect the stability.

## Shock Absorber for KTM 450 EXC **KT 1184**

### Mounting Instructions



Brand	Rider's weight* Spring kg/pounds	Spring rate N/mm	Titanium spring
KTM 450 SX-F	70/154	06320-16	06360-16
	75/165	06320-17	06360-17
	80/176	06320-18	06360-18
	85/187	06320-19	06360-19
	90/198	06320-20	06360-20
	95/209	06320-21	06360-21

\* Rider's weight: Rider wearing all riding equipment

## Install Spring

### 👁 Note!

Install the spring to the shock absorber before installing the shock absorber on the vehicle.

- 1 Measure the free length of the spring (A).
  - 2 Loosen the screw on the spring platform clamp so that you can move the spring platform as far up as needed to install the spring.
  - 3 Put the shock absorber up-side-down in a vice so that you can install the spring and the spring clip.
- 👁 **Note!**  
The spring platform and spring are press fitted. Push hard to install the spring.
- 4 Measure the spring length. Adjust the spring preload to the recommended setting, see *Set-up data* in this folder.
  - 5 Install the shock absorber to the vehicle according to the procedure in this folder. Check sag and ride height (see the Owner's Manual) and adjust the spring preload again if necessary.

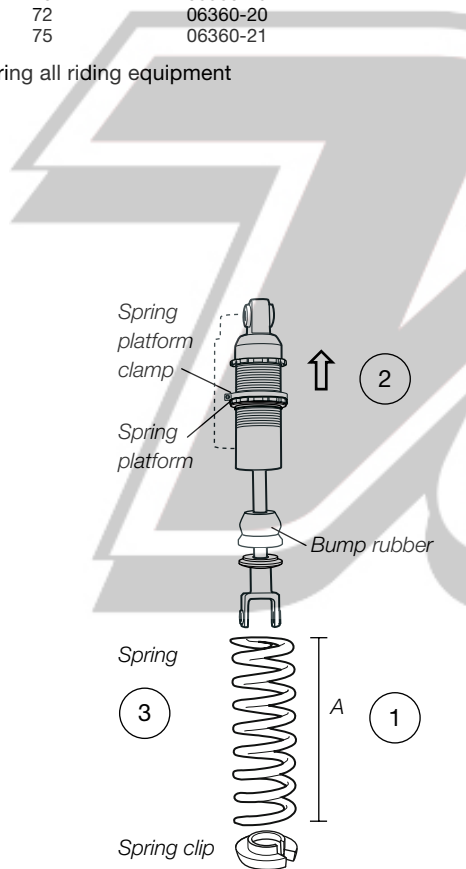

### 👁 Note!

Tighten the screw on the spring platform clamp before riding the motorcycle.

### ⚠ Warning!

It is advisable to have an Öhlins dealer install the shock absorber.

When installing, consult your Vehicle Service Manual.

- 1 Put the motorcycle on a workstand so that the rear wheel barely touches the ground.

### ⚠ Warning!

Make sure the vehicle is securely supported so that it will not tip.

- 2 Loosen the lower and the upper attachment of the original shock absorber. Remove it backwards and out to the right.

### 👁 Note!

Before installing the Öhlins shock absorber clean the vehicle thoroughly.

- 3 Install the Öhlins shock absorber in the same way as the original unit. Fasten it by using the two original screws, but do not tighten yet.

### ⚠ Warning!

In some cases the upper shock absorber bolt has a short thread, the bolt will risk bottoming before the shock absorber is correctly tightened. Vibrations can cause the bolt to loosen after some hours of use. If the bolt has a short thread, put a washer between the frame bracket and the upper bolt head.

### 👁 Note!

Lower the motorcycle so that the shock absorber is slightly compressed, before tightening the screws.

- 4 Tighten the upper and the lower attachments. Make sure that all removed parts are installed in the same way as they were before the installation.

### 👉 Caution!

Make sure that all screws are tightened to the correct torque and that nothing fouls or restricts movement of the shock absorber when the suspension is fully compressed or extended.

