

## **WARNING!**

The shock absorber is provided with a separate type reservoir filled with high-pressure nitrogen gas. To prevent danger of explosion, study and make certain that you fully understand the following information before handling the shock absorber. The manufacturer cannot be held responsible for damage to property or personal injury that may result from improper handling.

1. Never tamper with or attempt to disassemble the cylinder or the reservoir.

2. Never expose the shock absorber to an open flame or other excessive heat. The shock absorber may otherwise explode due to too high pressure.

3. Be careful not to damage any part of the gas reservoir. A damaged gas reservoir will impair the damping performance or cause malfunction.

4. Take care not to scratch the contact surface of the piston rod of the cylinder; oil could otherwise leak out.

5. Never attempt to remove the plug at the bottom of the nitrogen gas reservoir. Any attempt to remove the plug implies serious danger.

6. When scrapping the shock absorber, follow the instructions for disposal.

## **Notes**

# Mounting instructions

## KA 942 - KAWASAKI ZX-12R

### Kit content

Shock absorber 46 PRCLS	KA 942	1
Bolt	00439-11	1
Tie-rop	00231-01	2
Sticker Öhlins Racing AB	00192-01	2
Memo sticker	01180-01	1
Owners Manual		

### Set-up data

Length	338 mm + 12 mm
Stroke	67 mm
Compression adjustment	14 clicks
Rebound adjustment	14 clicks
Preload	17 mm

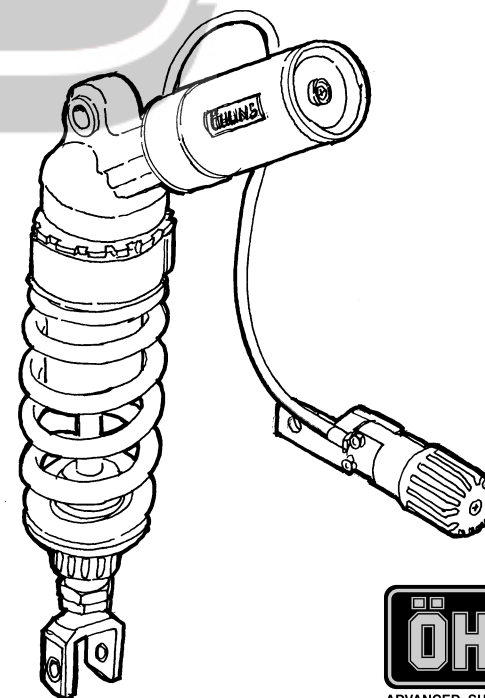

Traction, handling,  
comfort and safety



ADVANCED SUSPENSION TECHNOLOGY

Öhlins Racing AB, Box 722, S-194 27 Upplands Väsby, Sweden.  
Phone +46 8 590 025 00, fax +46 8 590 025 80.

E-mail: [info@ohlins.se](mailto:info@ohlins.se)  
Web: [www.ohlins.com](http://www.ohlins.com)

KA942, Issued 00 09 26



ADVANCED SUSPENSION TECHNOLOGY

## Safety signals

Important information concerning safety is distinguished in this manual by the following notations.



The Safety alert symbol means: **Caution! Your safety is involved.**

### WARNING!

Failure to follow warning instructions could result in **severe or fatal injury** to anyone working with, inspecting or using the suspension, or to bystanders.

### CAUTION!

Caution indicates that special precautions must be taken to avoid damage to the suspension.

### NOTE!

This indicates information that is of importance with regard to procedures.

## Kit contents

Before installing the shock absorber, please check the contents of the kit, listed on the front page of this instruction. If anything is missing, contact your Öhlins dealer.

### NOTE!

During storage and transportation, especially at high ambient temperature, the oil and grease used for assembling may run out inside the packing and damage the expanded polystyrene packing material. This is not unusual and is in no way detrimental to the shock absorber.

## Before you start

### WARNING!

Installing a shock absorber, that is not approved by the vehicle manufacturer, may affect the stability of your vehicle. Öhlins Racing AB cannot be held responsible for any personal injury or damage whatsoever that may occur after fitting the shock absorber. Contact an Öhlins dealer or other qualified person for advice.

Öhlins Racing AB can not be held responsible for any damage whatsoever to shock absorber or vehicle, or injury to persons, if the instructions for fitting and maintenance are not followed exactly. Similarly, the warranty will become null and void if the instructions are not adhered to.

### WARNING!

Please study and make certain that you fully understand all the mounting instructions and the owner's manuals before handling this shock absorber kit. If you have any questions regarding proper installation procedures, contact an Öhlins dealer or other qualified person.

### WARNING!

The vehicle service manual must be referred to when installing the Öhlins shock absorber.

### NOTE!

Öhlins products are subject to continual improvement and development. Consequently, although these instructions include the most up-to-date information available at the time of printing, there may be minor differences between your suspension and this manual. Please consult your Öhlins dealer if you have any questions with regard to the contents of the manual.

## Mounting Instructions

### 1

Put the motorcycle on a stand so the rear

### WARNING!

1. It's advisable to have an Öhlins dealer or other qualified person to fit your shock absorber.

2. Instructions in the vehicle service manual are to be followed when changing the shock absorber.

3. When working on a lifted vehicle it must be securely supported to prevent it from falling.

wheel is clear of the ground. The swing arm must be free, so the suspension is unloaded. Make sure it's steadily fixed so it will not fall over.

### 2

Loosen the rear attachments of the fairing, so it is possible to press it downwards and part it, to remove and refit the shock absorbers.

### 3

Loosen and remove the standard shock absorber. Take it out downwards, between the sidecovers of the fairing. See the motorcycles Workshop manual.

### 4

Fit the Öhlins shock absorber from downwards in the same position as the standard shock absorber.

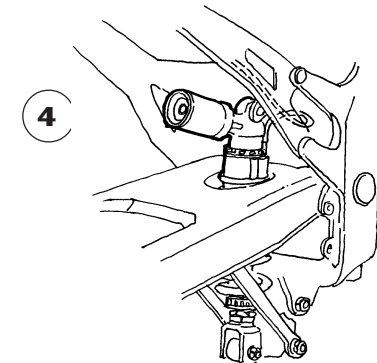

### 5

Attach the hydraulic preloader adjuster to the silencer bracket. Use the bolt (00439-11) provided. Mount the hose to the right side of the brake oil dispenser and make sure that it is positioned without tight bends. Use the tie raps provided to fix it in position.

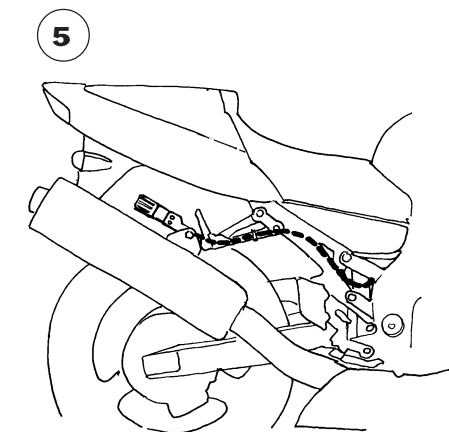

### 6

Continue your work according to the Owners Manual, section Adjustments

### NOTE!

Make sure that all bolts are tightened to the correct torque and that nothing fouls or restricts movement of the shock absorber when the suspension is being fully compressed or extended.

### WARNING!

Certain modifications may be necessary when installing the Öhlins shock absorber/suspension. It is essential that the mounting instructions are carefully followed.

© Öhlins Racing AB.  
All rights reserved.

Any reprinting or unauthorized use without the written permission of Öhlins Racing AB is prohibited.  
Printed in Sweden.