



## Safety signals

Important information concerning safety is distinguished in this manual by the following notations.



The Safety alert symbol means: Caution! Your safety is involved.

### WARNING!

Failure to follow warning instructions could result in **severe or fatal injury** to anyone working with, inspecting or using the suspension, or to bystanders.

### CAUTION!

Caution indicates that special precautions must be taken to avoid damage to the suspension.

### NOTE!

This indicates information that is of importance with regard to procedures.

## Kit contents

Before installing the shock absorber, please check the contents of the kit, listed on the front page of this instruction. If anything is missing, contact your Öhlins dealer.

### NOTE!

During storage and transportation, especially at high ambient temperature, the oil and grease used for assembling may run out inside the packing and damage the expanded polystyrene packing material. This is not unusual and is in no way detrimental to the shock absorber.

## Before you start

### WARNING!

*Installing a shock absorber, that is not approved by the vehicle manufacturer, may affect the stability of your vehicle. Öhlins Racing AB cannot be held responsible for any personal injury or damage whatsoever that may occur after fitting the shock absorber. Contact an Öhlins dealer or other qualified person for advice.*

Öhlins Racing AB can not be held responsible for any damage whatsoever to shock absorber or vehicle, or injury to persons, if the instructions for fitting and maintenance are not followed exactly. Similarly, the warranty will become null and void if the instructions are not adhered to.

### WARNING!

*Please study and make certain that you fully understand all the mounting instructions and the owner's manuals before handling this shock absorber kit. If you have any questions regarding proper installation procedures, contact an Öhlins dealer or other qualified person.*

### WARNING!

*The vehicle service manual must be referred to when installing the Öhlins shock absorber.*

### NOTE!

*Öhlins products are subject to continual improvement and development. Consequently, although these instructions include the most up-to-date information available at the time of printing, there may be minor differences between your suspension and this manual. Please consult your Öhlins dealer if you have any questions with regard to the contents of the manual.*

## Mounting instructions

### 1

Remove seat, side covers, battery with holder and loosen the electric panel on the left side. Remove the mounting screw for the expansion vessel.

### WARNING!

*1. It's advisable to have an Öhlins dealer or other qualified person to fit your shock absorber.  
2. Instructions in the vehicle service manual are to be followed when changing the shock absorber.  
3. When working on a lifted vehicle it must be securely supported to prevent it from falling.*

### 2

Remove the damping adjustment rod.

### 3

Loosen the air filling hose.

### 4

Remove the upper mounting bolt.

### 5

Remove the bolt that connects the front and rear link.

### 6

Remove the upper mounting bolt.

### 7

Pull down the shock absorber downwards.

### 8

Mounting the Öhlins shock absorber: The damper is mounted from underneath by first pulling through the master cylinder for the spring pre-load adjuster.

### 9

Mount the upper bolt.

### 10

Mount the bolt that connects the front and rear links. Make shure that the bearings are well greased and that the seals are not damaged.

### 11

Lift up the swing arm and mount the lower mounting screw and the supplied washer and nut.

### 12

Tighten the upper and lower mountingbolts and the one that connects the rear and front links.

### 13

The hose routing is done according to the sketch.

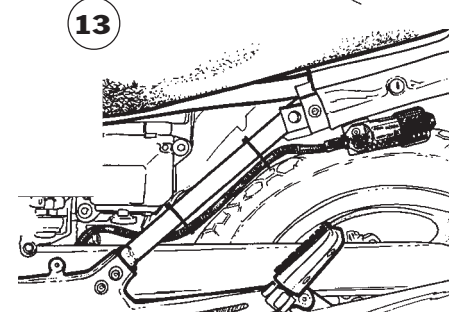
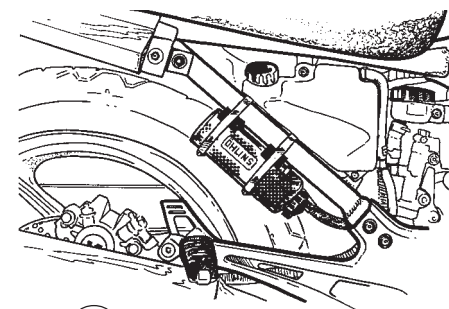

© Öhlins Racing AB.  
All rights reserved.

Any reprinting or unauthorized use without the written permission of Öhlins Racing AB is prohibited.  
Printed in Sweden.