

ADJUSTMENTS

1 Spring preload

Loosen the screw of the spring platform clamp. Use the C-spanner provided in this kit, turn the spring platform to the desired position. Or, when installed on the vehicle, turn the spring. Tighten the screw of the spring platform clamp.

2 Compression damping

Adjust by turning the screw in the middle of the **golden** knob on top of the reservoir. Use a screwdriver and turn the screw clockwise to *increase* damping, turn counter clockwise to *decrease* damping.

3 Rebound damping

Adjust by turning the screw in the middle of the **black** knob on top of the reservoir. Use a screwdriver and turn the screw clockwise to *increase* damping, turn counter clockwise to *decrease* damping.

4 CSC Adjuster

Use a screwdriver and turn the screw clockwise to *increase* damping, turn counter clockwise to *decrease* damping.

Adjuster settings:

The adjusters have a normal right hand thread. Turn the damping adjusters clockwise to fully closed (position zero [0]). Then, turn counter clockwise to open, and count the clicks until you reach the recommended number of clicks.

See **Set-up data**.

⚠ WARNING!

When delivered, the Öhlins shock absorber is dialed to the recommended settings for the specific brand and make of the motorcycle. Before riding, always ensure that the basic settings made by Öhlins are intact.

Do not use force, delicate sealing surfaces can be damaged. Handtighten only!

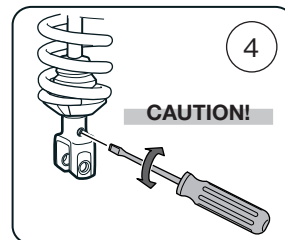
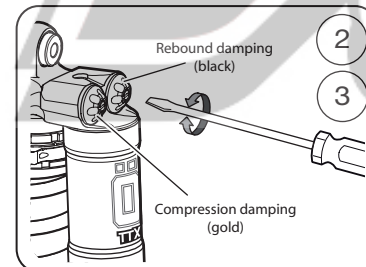
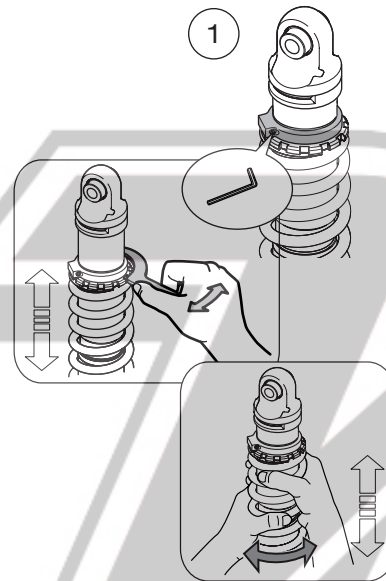

Mounting Instruction

WITH SET-UP DATA

SHOCK ABSORBER KA894 for Kawasaki KX 450F 2008

Before installing this product, check the contents of the kit listed below. If anything is missing, please contact your nearest Öhlins dealer.

Kit Contents:

	Part no.	Pcs.
Shock absorber	KA894	1
Spring clip	00629-06	1
Screw	00439-20	1
C-spanner	00710-02	1
Öhlins Sticker	00197-01	2
Memo notes Sticker	01180-01	1
Information sheet	01198-01	1
Owner's Manual	07253-01	1

NOTE!

No spring included in this kit. See the Spring Guide in this folder, or contact at Öhlins dealer for advice.

During storage and transportation, especially at high ambient temperature, some of the oil and grease used for assembling may leak and stain the packaging. This is in no way detrimental to the product, wipe off the excessive oil/grease with a cloth.

Set-up data

Spring preload	5 turns (10 mm)
Rebound damping	10 clicks
Compression damping	10 clicks
CSC damping	18 clicks

Shock absorber data

Length	486 mm
Stroke	138,5 mm

Free sag and Ride height

Free sag, rear	30±5 mm
Free sag, front	30±5 mm
Ride height, rear	100-105 mm
Ride height, front	80±5 mm

Read the Öhlins Owner's Manual before installing this product



Öhlins Racing AB, Box 722, S-194 27 Upplands Väsby, Sweden.
Phone +46 8 590 025 00 Fax +46 8 590 025 80
www.ohlins.com

SPRING GUIDE

Brand	Rider's weight*	Spring	Spring rate	Titanium spring
	kg/pounds	N/mm		
Kawasaki KX 450F	70/154	06310-07	46	06350-07
	75/165	06310-08	48	06350-08
	80/176	06310-09	50	06350-09
	85/187	06310-10	52	06350-10
	90/198	06310-11	54	06350-11
	95/209	06310-12	56	06350-12

* Rider's weight: Rider wearing all riding equipment

INSTALL THE SPRING

NOTE!

Install the spring to the shock absorber before installing the shock absorber on the vehicle.

1

Measure the free length of the spring (A).

2

Loosen the screw on the spring platform clamp so that you can move the spring platform as far up as needed to install the spring.

3

Put the shock absorber up-side-down in a vice so that you can install the spring and the spring clip.

NOTE!

The spring platform and spring are press fitted. Push hard to install the spring.

4

Measure the spring length. Adjust the spring preload to the recommended setting, see section **Adjustments** and **Set-up data** in this folder.

5

Install the shock absorber to the vehicle according to the procedure in this folder. Check sag and ride height (see the Owner's Manual) and adjust the spring preload again if necessary.

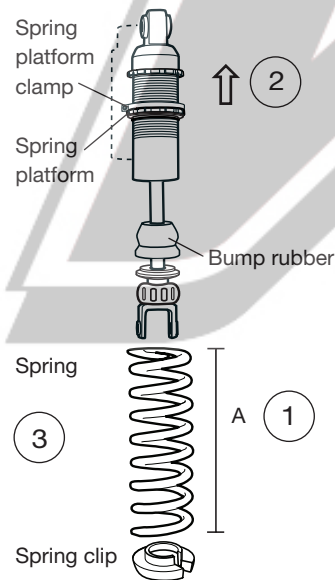

NOTE!

Tighten the screw on the spring platform clamp before riding the motorcycle.

INSTALL THE SHOCK ABSORBER

WARNING!

It is advisable to have an Öhlins dealer install the shock absorber.

1

Raise the rear end of the vehicle so that the rear wheel barely touches the ground.

WARNING!

Make sure the vehicle is securely supported so that it will not tip.

2

Remove the seat.

3

Remove the right side number plate.

4

Loosen the silencer from the subframe. Leave it attached to the exhaust pipe.

5

Loosen the subframe from the frame. Remove the hose clamp holding the airbox to the carburetor. Remove the whole unit with rear fender, subframe and air box.

6

Loosen the lower and the upper attachment of the original shock absorber and remove it.

7

Install the Öhlins shock absorber in the same way as the original unit. Replace the original upper attachment screw with the enclosed screw.

NOTE!

Lower the motorcycle so that the shock absorber is slightly compressed, before tightening the screws.

8

Put the air box, subframe, rear fender, number plate and seat back in position and fasten them. Make sure that all removed parts are installed in the same way as they were before the installation.

WARNING!

Make sure that all screws are tightened to the correct torque and that nothing fouls or restricts movement of the shock absorber when the suspension is being fully compressed or extended.

