

ADJUSTMENTS

Always ensure that the basic settings made by Öhlins are intact.

1 Spring Preload

Turn the knob on the hydraulic preload adjuster to set the spring preload. Turn clockwise to increase the preload, turn counter clockwise to decrease it.

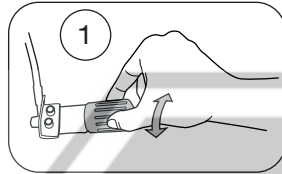

2 Rebound

Turn the wheel on the piston shaft above the end eye/bracket. Turn clockwise to increase damping, turn counter clockwise to decrease.

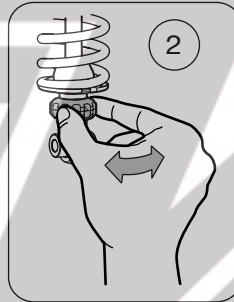

NOTE!

When delivered the Öhlins shock absorber is dialed to the recommended settings for the specific vehicle model. If you have changed the setting, reset according to the following:

The adjuster has a right hand thread. Turn the adjuster clockwise to fully closed (pos. zero [0]). Turn counter clockwise to open and count the clicks until you reach the recommended number (see Set-up Data).

CAUTION!

Do not use force, delicate sealing surfaces can be damaged. Handtighten only.

3 Length

We recommend you to adjust the length before installing the shock absorber to the vehicle. Use two wrenches. Hold the upper nut with one hand and at the same time loosen the lock nut (lower nut). Turn the end eye/ bracket to the desired length. Lock the lock nut. Tightening torque: 40 Nm

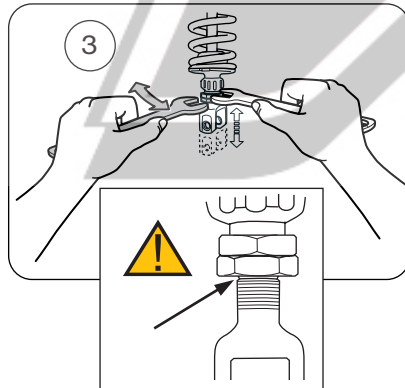

WARNING!

The adjustable end eye/bracket must not be threaded out more than that the groove is fully visible beneath the lock nut. This is maximum length. After adjusting, make sure that the lock nut is tightened.

Mounting Instructions

WITH SET-UP DATA

SHOCK ABSORBER KA762 for Kawasaki VN 2000

Before installing this shock absorber, check the contents of the kit listed below. If anything is missing, please contact your nearest Öhlins dealer.

Kit Contents:

	Part no.	Pcs.
Shock absorber	KA762	1
Bracket	20028-01	1
Screw MC6S	01046-01	2
Öhlins Sticker black	00191-13	2
Öhlins Sticker white	00191-20	2
Memo Notes Sticker	01180-01	1
Owner's Manual	07241-02	1

During storage and transportation, especially at high ambient temperature, some of the oil and grease used for assembling may leak and stain the packaging. This is in no way detrimental to the product, wipe off the excessive oil/grease with a cloth.

Set-up Data

Spring preload	20,5 mm
Rebound damping	20 clicks

Shock absorber length	320,5 ⁺⁰ ₋₁₂ mm
Stroke	33,5 mm

Spring	21014-69
Free spring length	140 ⁺⁰ ₋₃ mm

Before installing this product, read the Öhlins Owner's Manual!

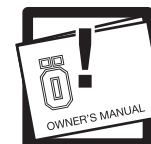

HOW TO INSTALL

⚠ WARNING!

It is advisable to have an Öhlins dealer install the shock absorber.

1

Put the motorcycle on a workstand so that the rear wheel barely touches the ground.

⚠ WARNING!

Make sure the vehicle is securely supported so that it will not tip.

2

Remove the right side cover. Pull the strap under the cover to loosen the passenger seat, and remove it.

3

Remove the left side cover.

4

Remove the driver seat.

5

Remove the battery box cover.

6

Loosen the 4 screws indicated in the figure. Gently fold out the lid.

7

Remove the front attachment of the original shock absorber.

8

Remove the rear attachment. Remove the original shock absorber.

NOTE!

Recommendation! Before installing the Öhlins shock absorber:

- clean the vehicle thoroughly
- adjust the length of the shock absorber (check the headlight angle after adjusting the length!)

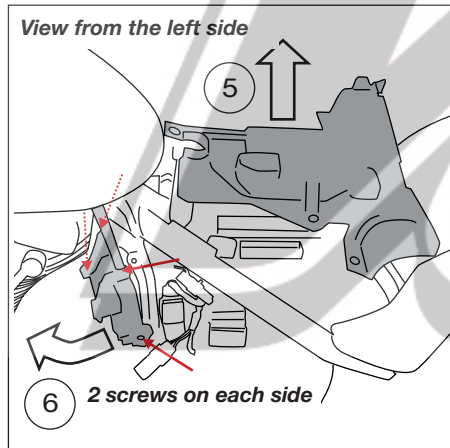

9

Install the Öhlins shock absorber. Lead the hydraulic preload adjuster hose out to the right side, then behind the plastic lid and through the vaulted part as indicated in the figure. Leave it temporarily while fastening the shock absorber body.

10

Fasten the front and the rear attachments of the Öhlins shock absorber, do not tighten yet.

NOTE!

Lower the motorcycle so that the shock absorber is slightly compressed, before tightening the screws.

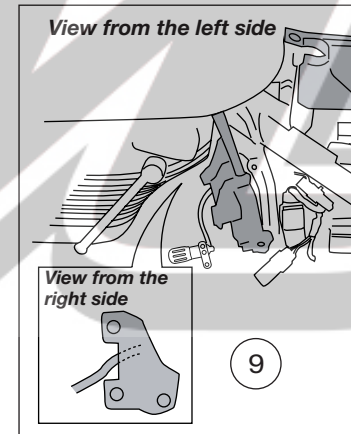

11

Tighten the front and the rear attachments.

12

Fasten the bracket, provided in this kit, to the hydraulic preload adjuster.

⚠ WARNING!

Make sure that the hydraulic preload adjuster hose runs in soft bends. Also check that it does not come in contact with the exhaust pipe or any sharp edges.

13

Install the bracket and the adjuster to the screw on the engine cover as indicated in the figure.

14

Reattach the lid with the 4 screws, the battery box cover, driver seat, left and right side covers and the passenger seat. Make sure that all removed parts are installed in the same way as they were before the installation.

NOTE!

Make sure that all screws are tightened to the correct torque and that nothing fouls or restricts movement of the shock absorber when the suspension is being fully compressed or extended.

