

Note!

Please note that there can be small differences between your product and the images in these instructions.

Note!

Please note that during storage and transport, especially at high ambient temperature, some of the oil and grease used for assembly may leak and stain the packaging. This will not cause damage to the product, wipe off the excessive oil or grease with a cloth.

Kit Contents

Description	Part No	Pcs
Shock absorber STX 46	KA 1490	1
Spring clip for 57mm spring	00516-01	1
Owners manual	07251-02	1
Sticker set "Öhlins"	10207-01	1

Note!

No spring included in this kit. See the spring guide in this folder or contact an Öhlins dealer for advice.

Note!

Before you install this product, check the kit contents. If anything is missing, please contact an Öhlins dealer.

Warning!

Before you install this product, read the Öhlins Owner's manual. This product is an important part of the vehicle and the vehicle stability.

Shock absorber for Kawasaki KX85 2014-2015

KA 1490

Mounting Instructions



SPRING GUIDE

Rider's weight* kg/pounds	Spring part no	Spring rate N/mm
<i>Kawasaki KX 85</i>		
35/77	00698-05	42
40/88	00698-06	44
45/99	00698-07	46
50/110	00698-08	48
55/121	00698-09	50
>60/132	00698-10	52

* Rider's weight: Rider wearing proper riding gear. Make sure you know your total weight with riding gear. Riding gear weighs between 5 and 15 kg.

INSTALL THE SPRING

👁 **Note!**

Install the spring on the shock absorber before you install the shock absorber on the vehicle.

1

Measure spring free length (A).

2

Loosen the spring platform clamp screw so that you can move the spring platform as far up as needed to install the spring.

3

Put the shock absorber up-side-down in a vice. Install the spring and the spring clip.

👁 **Note!**

The spring platform and the spring are press fitted. Push hard to install the spring.

4

Measure the spring length. Adjust the spring preload to the recommended setup data in this folder.

👋 **Caution!**

Tighten the spring platform clamp screw before riding.

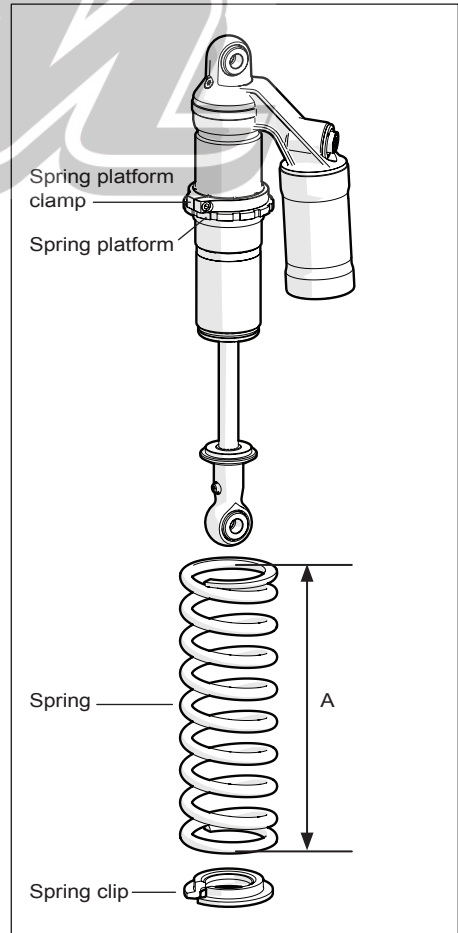

MOUNTING INSTRUCTIONS

⚠ Warning!

We strongly recommend to let an Öhlins dealer install this product.

⚠ Warning!

If you work with a lifted vehicle, make sure that it is safely supported to prevent it from tipping over.

👁 Note!

When you work with this product, see the vehicle service manual for vehicle specific procedures and important data.

👁 Note!

Before you install this product clean the vehicle.

1

Install the Öhlins shock absorber according to the vehicle manual.

👁 Note!

Lower the vehicle so that the suspension is slightly compressed before you tighten the screws.

👋 Caution!

Make sure that you tighten all screws to the correct torque and that nothing fouls or restricts movement of the shock absorber/front fork/steering damper when the suspension is fully compressed or extended.

ADJUSTMENTS

⚠ Warning!

Before you ride/drive, always make sure that the setup is according to the recommended setup data. Read about adjustments and setting up in the Öhlins Owner's Manual before you make any adjustments. Contact an Öhlins dealer if you have any questions about setting up.

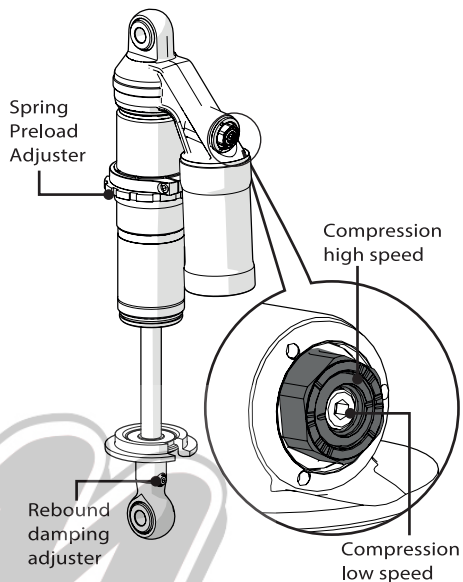

SETUP DATA

Length	378	mm
Stroke	108	mm
Spring part no	00698-xx	
Spring free length	220±3	mm
Comp high speed	11	
Comp low speed	12	clicks
Rebound	18	clicks

Recommended Free sag and Ride height		
R1-R2	25±5	mm
R1-R3	70±5	mm

Öhlins products are subject to continuous improvement and development, therefore, although these instructions include the most up-to-date information available at the time of printing, minor updates may occur.

To find the latest information contact an Öhlins distributor. Please contact Öhlins if you have any questions regarding the contents in this document.

Part no. MI_KA1490_0
Issued 2014-06-26

© Öhlins Racing AB. All rights reserved. Any reprinting or unauthorized use without the written permission of Öhlins Racing AB is prohibited.

Öhlins Racing AB
Box 722
S-194 27 Upplands Väsby, Sweden
Phone +46 8 590 025 00
fax +46 8 590 025 80



www.ohlins.com