

# Adjustments

## ⚠ Warning!

Before riding, always make sure that the basic settings made by Öhlins are according to recommended Set-up Data. Read about adjustments and setting up in the Öhlins Owner's Manual before you make any adjustments. Contact an Öhlins dealer if you have any questions about setting up the shock absorber.

Öhlins Shock Absorber HO 993

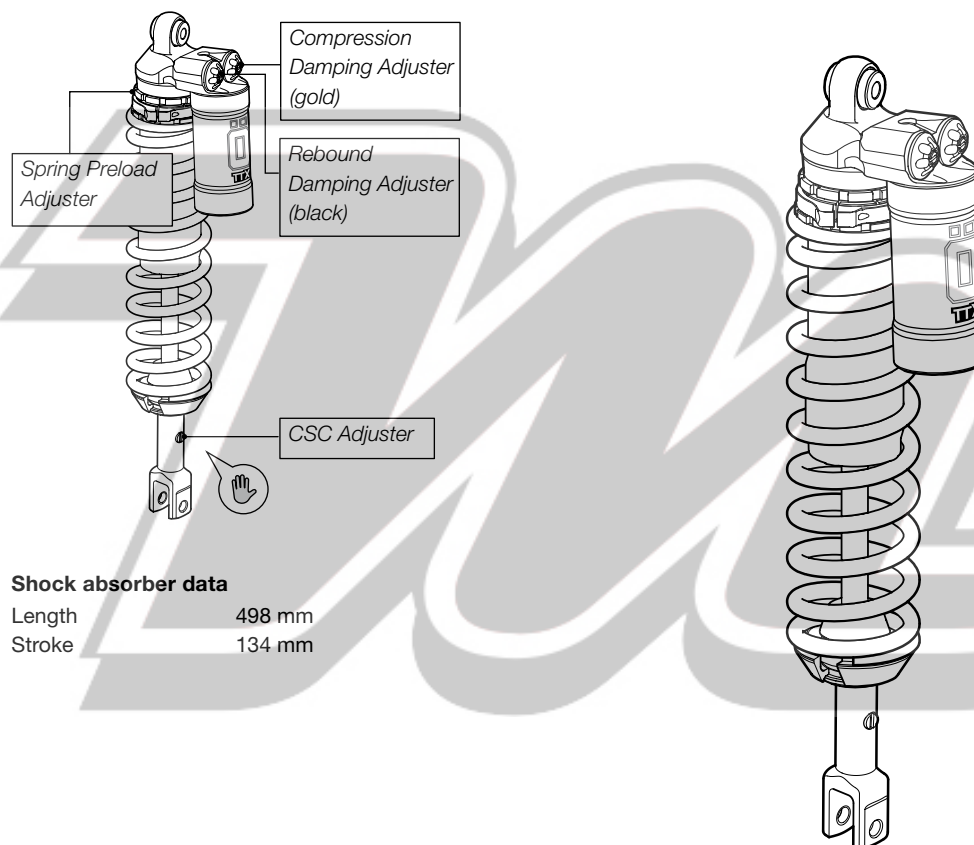

# Set-up Data

## Recommended set-up

Spring preload 5 turns (10 mm)  
 Rebound damping 10 clicks  
 Compression damping 10 clicks  
 CSC damping 18 clicks

## Free sag and Ride height

Free sag, rear 30±5 mm  
 Free sag, front 30±5 mm  
 Ride height, rear 100-105 mm  
 Ride height, front 80±5 mm

## Shock absorber data

Length 498 mm  
 Stroke 134 mm

Before installing this product, check the contents of the kit. If anything is missing, please contact your nearest Öhlins dealer.

## Kit Contents

	Part No.	Pcs.
Shock absorber	HO993	1
C-spanner	00710-02	1
Spring clip	00629-06	1
Öhlins Sticker	00197-01	2
Memo notes Sticker	01180-01	1
Owner's Manual	07253-01	1
Information sheet	01198-01	1

## 👁 Note!

No spring included in this kit. See the Spring Guide in this folder, or contact an Öhlins dealer for advise.

Please note that during storage and transportation, especially at high ambient temperature, some of the oil and grease used for assembling may leak and stain the packaging. This is in no way detrimental to the product, wipe off the excessive oil/grease with a cloth.

## ⚠ Warning!

Before installing this product, read the Öhlins Owner's Manual. The shock absorber is an important part of your vehicle and may affect the stability of your vehicle.

👁 Öhlins products are subject to continuous improvement and development, therefore, although these instructions include the most up-to-date information available at the time of printing, minor updates may occur.

To find the latest information contact your Öhlins distributor. Please consult your Öhlins dealer if you have any questions regarding the contents in this document.

Part no. HO993\_0  
 Issued 2008-11-20



# Shock Absorber for Honda CRF 250R HO 993

## Mounting Instructions

© Öhlins Racing AB. All rights reserved. Any reprinting or unauthorized use without the written permission of Öhlins Racing AB is prohibited.

Öhlins Racing AB  
 Box 722  
 S-194 27 Upplands Väsby, Sweden  
 Phone +46 8 590 025 00  
 fax +46 8 590 025 80



[www.ohlins.com](http://www.ohlins.com)



Brand	Rider's weight* kg/pounds	Spring	Spring rate N/mm	Titanium spring
Honda CRF 250	70/154	06310-07	46	06350-07
	75/165	06310-08	48	06350-08
	80/176	06310-09	50	06350-09
	85/187	06310-10	52	06350-10
	90/198	06310-11	54	06350-11
	95/209	06310-12	56	06350-12

\* Rider's weight: Rider wearing all riding equipment

## Install the Spring

### 👁 Note!

Install the spring to the shock absorber before installing the shock absorber on the vehicle.

- 1 Measure the free length of the spring (A).
- 2 Loosen the screw on the spring platform clamp so that you can move the spring platform as far up as needed to install the spring.
- 3 Put the shock absorber up-side-down in a vice so that you can install the spring and the spring clip.

### 👁 Note!

The spring platform and spring are press fitted. Push hard to install the spring.

- 4 Measure the spring length. Adjust the spring preload to the recommended setting, see section *Adjustments and Set-up data* in this folder.

- 5 Install the shock absorber to the vehicle according to the procedure in this folder.

Check sag and ride height (see the Owner's Manual) and adjust the spring preload again if necessary.

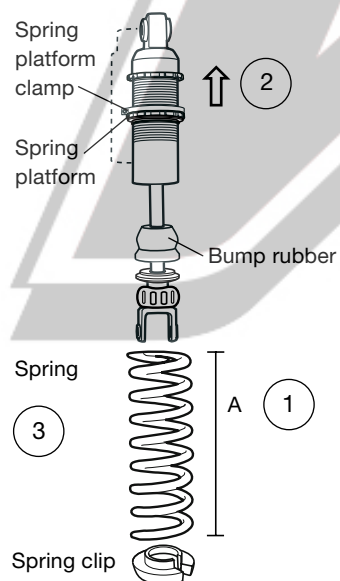

### 👁 Note!

Tighten the screw on the spring platform clamp before riding the motorcycle.

### ⚠ Warning!

It is advisable to have an Öhlins dealer install the shock absorber.

When installing, consult your Vehicle Service Manual.

- 1 Put the motorcycle on a workstand so that the rear wheel barely touches the ground.

### ⚠ Warning!

Make sure the vehicle is securely supported so that it will not tip.

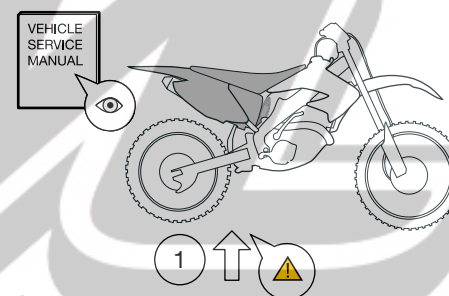

- 2 Remove the seat.
- 3 Remove the number plate. Loosen the silencer from the sub frame, leave it attached to the exhaust pipe.

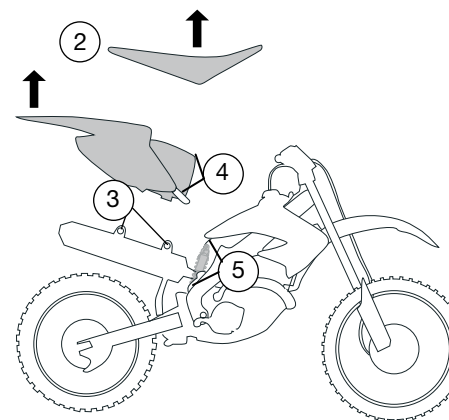

- 4 Loosen the sub frame from the frame.
- 5 Loosen the upper and the lower attachments of the original shock absorber and remove it.

### 👁 Note!

Before installing the Öhlins shock absorber clean the vehicle thoroughly.

- 6 Install the Öhlins shock absorber in the same way as the original unit. Use the original attachment screws. Do not tighten yet.

### 👁 Note!

Lower the motorcycle so that the shock absorber is slightly compressed, before tightening the screws.

- 7 Tighten the attachment screws.

- 8 Put the air box, sub frame and seat back in position and fasten them. Make sure that all removed parts are installed in the same way as they were before the installation.

### 👁 Caution!

Make sure that all screws are tightened to the correct torque and that nothing fouls or restricts movement of the shock absorber when the suspension is fully compressed or extended.