

**8**

Reassemble the triangle link and fit the lower bracket of the shock absorber.

**9**

Fit the external reservoir to the frame on the left side. Use the provided hose clamps and position the rubber mounts between the reservoir and the frame.

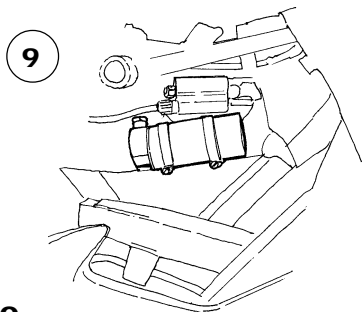

**10**

**NOTE!**

*Make sure that all bolts are tightened to the correct torque and that nothing fouls the shock absorber when the suspension is being fully compressed or extended. Check with the Service Manual of the motorbike for correct torque.*

**10**

Fit the hydraulic spanner adjustment to the foot rest bracket. Use the bolt provided (M8 x 30). Fix the hose by using tie raps.

**11**

Mount the side covers and the seat.

**Notes**

---



---



---



---



---

Traction, handling,  
comfort and safety



ADVANCED SUSPENSION TECHNOLOGY

Öhlins Racing AB, Box 722, S-194 27 Upplands Väsby, Sweden.

Phone +46 8 590 025 00, fax +46 8 590 025 80.

# Mounting instructions

## HO 851 - HONDA Varadero

### Kit contents

1. Shock absorber Type 46HRCS	Ho851	1
2. Bolt MC6S 8x50	01046-25	1
3. Hose clamp stainless	00643-02	2
4. Rubber mount reservoir	00230-01	2
5. Tie rap L=186	00231-01	1
6. Sticker Öhlins	00192-01	2
7. Sticker Memo note	01180-01	1
8. Owners Manual		

### Set-up data

Length	338 mm
Stroke	65 mm
Rebound adjustment	14
Compression adjustment	10
Preload	10 mm

### Rec. Free Sag and Ride Height

F1 - F2:	40 - 50 mm
F1 - F3:	55 - 65 mm
R1 - R2:	25 - 35 mm
R1 - R3:	50 - 60 mm

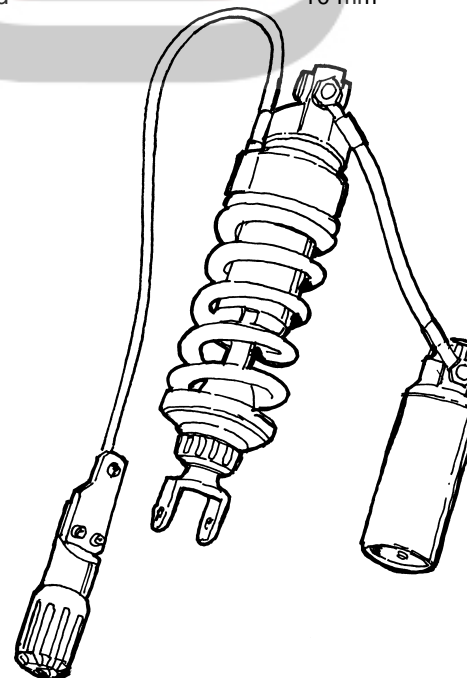

HO851\_1 Issued 2009 07 06



ADVANCED SUSPENSION TECHNOLOGY

## Safety signals

Important information concerning safety is distinguished in this manual by the following notations



The Beware sign means:  
Pay attention!  
Your safety is at risk.

### ⚠ WARNING!

Failure to follow Warning text could result in **serious or fatal injury** to anyone working with, inspecting or using the suspension, or to bystanders.

### CAUTION!

Caution indicates special precautions that must be taken to avoid damage to the suspension.

### NOTE!

This indicates information that is of importance with regard to procedures

## Kit contents

Before installing the shock absorber kit, please check the contents, listed on the front page of this instruction. If anything is missing, contact your Öhlins dealer.

### NOTE!

During storage and transportation, especially at high ambient temperature, the oil and grease used for assembling may run out inside the packing and damage the expanded polystyrene packing material. This is not unusual and is in no way detrimental to the shock absorber.

## Before you start

### ⚠ WARNING!

Installing a shock absorber, that is not approved by the motorcycle manufacturer, may affect the stability of your motorcycle. Öhlins Racing AB can't be held responsible for any personal injury or damage whatsoever which may occur after fitting the shock absorber.

Öhlins Racing AB can not be held responsible for any damage whatsoever to spare parts, or injury to persons, if the instructions for servicing and maintenance are not followed exactly. Similarly, the guarantees relating to performance and reliability will become null and void if the instructions are not adhered to.

### ⚠ WARNING!

Please study the mounting instructions and the owner's and workshop manuals thoroughly before handling this shock absorber kit.

### ⚠ WARNING!

When installing the Öhlins shock absorber the motorcycle workshop manual must be at hand.

### NOTE!

Öhlins products are subject to continual improvement and development in design and quality. Consequently, although these instructions include the most up-to-date information available at the time of printing, there may be minor differences between your suspension and this manual. Please consult your Öhlins dealer if you have any questions concerning the manual.

## Mounting instructions

**1**

Put the motorcycle on a stand so the rear wheel is off the ground. Make sure it's steady and will not fall over. The center stand is excellent if it is risen a few inches.

### ⚠ WARNING!

1. It's advisable to have an Öhlins dealer or other qualified person to fit your shock absorber.
2. Instructions in the motorcycle workshop manual are to be followed when changing the shock absorber.
3. When working on the motorcycle it must be securely supported to prevent it from falling over.

**4**

Loosen first the upper and then the lower shock absorber attachment.

**5**

Loosen the triangle link and remove it.

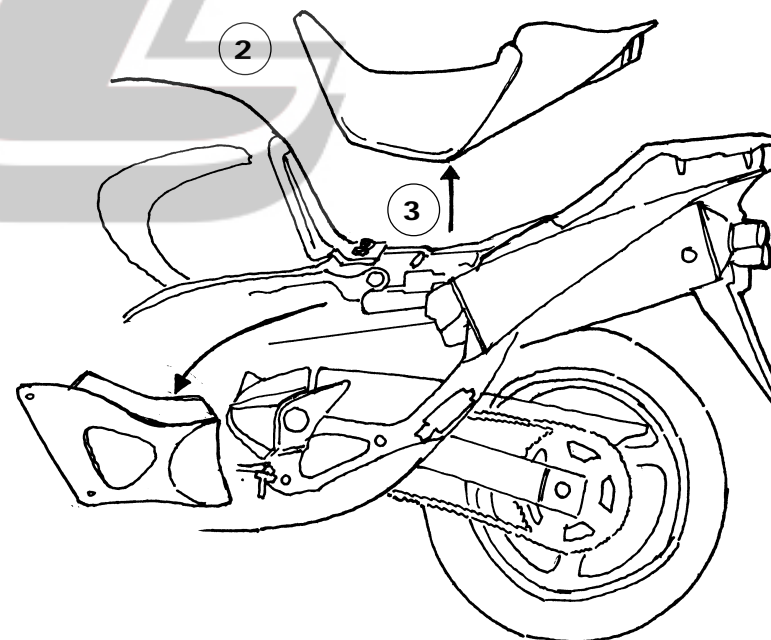
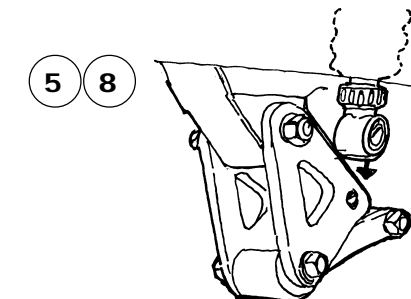

**2**

Unlock the seat and remove it. Remove the left and right side covers.

**3**

Remove the wheel of the hydraulic preload adjuster.

**6**

Remove the shock absorber downwards.

**7**

Fit the Öhlins shock absorber by positioning it from underneath. Fit the upper bracket.

© Öhlins Racing AB.  
All rights reserved.

Any reprinting or unauthorized use without the written permission of Öhlins Racing AB is prohibited.  
Printed in Sweden.