

# Adjustments

## ⚠ Warning!

Before riding, always make sure that the basic settings made by Öhlins are according to recommended Set-up Data. Read about adjustments and setting up in the Öhlins Owner's Manual before you make any adjustments. Contact an Öhlins dealer if you have any questions about setting up the shock absorber.

### Öhlins Shock Absorber S46ER1S HO 823

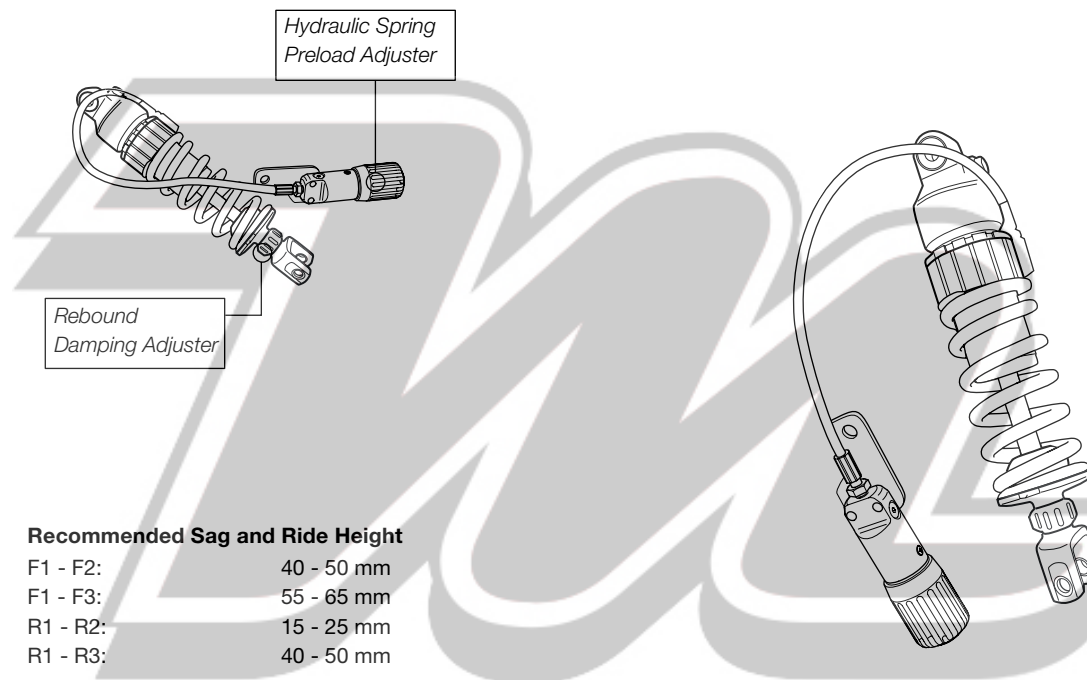

Before installing this product, check the contents of the kit. If anything is missing, please contact your nearest Öhlins dealer.

### Kit Contents

	Part No.	Pcs.
Shock Abs. S46ER1S	HO 823	1
Tie wrap	00231-01	4
Nut M10	00430-01	1
Screw MC6S 10x55	01046-48	1
Öhlins Sticker	00192-01	2
Memo Notes Sticker	01180-01	1
Owner's Manual	07241-02	1

Please note that during storage and transportation, especially at high ambient temperature, some of the oil and grease used for assembling may leak and stain the packaging. This is in no way detrimental to the product, wipe off the excessive oil/grease with a cloth.

## ⚠ Warning!

Before installing this product, read the Öhlins Owner's Manual. The shock absorber is an important part of your vehicle and may affect the stability of your vehicle.

# Set-up Data

### Recommended set-up

Rebound	16 clicks
Spring Preload	11 mm
<b>Spring</b>	
Part No.	Rate
01092-59	150 N/mm
Free spring length	170 mm

Shock Absorber length	316 mm
Stroke	65

### Recommended Sag and Ride Height

F1 - F2:	40 - 50 mm
F1 - F3:	55 - 65 mm
R1 - R2:	15 - 25 mm
R1 - R3:	40 - 50 mm

👁 Read more about sag and ride height in the Öhlins Owner's Manual.

👁 Öhlins products are subject to continuous improvement and development, therefore, although these instructions include the most up-to-date information available at the time of printing, minor updates may occur.

To find the latest information contact your Öhlins distributor. Please consult your Öhlins dealer if you have any questions regarding the contents in this document.

Part no. HO823\_1  
Issued 2009-05-28



© Öhlins Racing AB. All rights reserved. Any reprinting or unauthorized use without the written permission of Öhlins Racing AB is prohibited.

Öhlins Racing AB  
Box 722  
S-194 27 Upplands Väsby, Sweden  
Phone +46 8 590 025 00  
fax +46 8 590 025 80



[www.ohlins.com](http://www.ohlins.com)

# Shock Absorber for Honda XL 700V/ VA Transalp HO 823

## Mounting Instructions



## ⚠ Warning!

It is advisable to have an Öhlins dealer install the shock absorber.

When installing, consult your Vehicle Service Manual.

**1**  
Put the motorcycle on a workstand so that the rear wheel barely touches the ground.

## ⚠ Warning!

Make sure the vehicle is securely supported so that it will not tip.

**2**  
Remove the seats and side covers.

**3**  
Remove the mud guard between the shock absorber and the rear wheel.

**4**  
Remove the attachment bolts and remove the original shock absorber.

## 👁 Note!

Before installing the Öhlins shock absorber clean the vehicle thoroughly.

**5**  
Install the Öhlins shock absorber, the preload adjuster on the left side of the vehicle. The gas valve towards the rear. Do not tighten yet.

## 👉 Caution!

Make sure that the ventilation hoses on the right side of the shock absorber are not squeezed when installing the shock absorber. If necessary, put one of them on the left side of the shock absorber and fix it with the tie wraps provided.

**6**  
Reinstall the attachment bolts. Use the M10x55 bolt and nut supplied for the lower bracket.

## 👁 Note!

Lower the motorcycle so that the shock absorber is slightly compressed, before tightening the screws.

**7**  
Tighten the attachment bolts to the correct torque according to the Honda specs.

**8**  
Install the preload adjuster on the left side at the passenger foot peg bracket according to the figure. Use 2 of the tie wraps for the preload adjuster hose.

**9**  
Reinstall the mud guard, seats and side covers. Make sure that all removed parts are reinstalled in the same way as they were before the installation of the Öhlins shock absorber.

## 👉 Caution!

Make sure that all screws are tightened to the correct torque and that nothing fouls or restricts movement of the shock absorber when the suspension is fully compressed or extended.

