

Owners Manual

Mounting instructions Öhlins shock absorber kit HO 801 for Honda VFR 800 F1

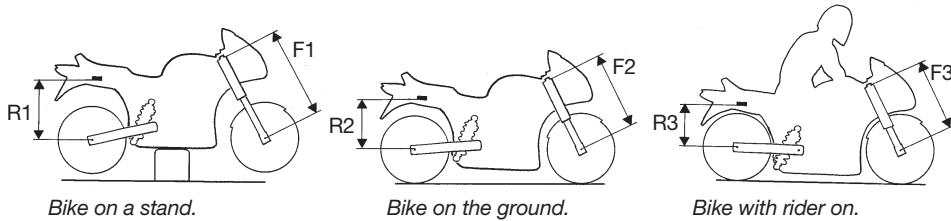

Setup data

Shock absorber length	325 mm
Shock absorber stroke	58 mm
Shock absorber spring part No.	01092-59
Spring preload	12 mm
Rebound damping adjuster	14 clicks
Compression damping adjuster	12 clicks

Checking sag and ride height

Front suspension

- F1. Bike on a stand with the suspension fully extended =
- F2. Bike on the ground without rider =
- F3. Bike on the ground with rider =

Free sag $F1 - F2 = \dots\dots\dots$

Ride height $F1 - F3 = \dots\dots\dots$

Rear suspension

- R1. Bike on a stand with the suspension fully extended =
- R2. Bike on the ground without rider =
- R3. Bike on the ground with rider =

Free sag $R1 - R2 = \dots\dots\dots$

Ride height $R1 - R3 = \dots\dots\dots$

NOTE!

*If ride height is higher than recommended, softer spring/springs must be used.
If ride height is lower than recommended, harder spring/springs must be used.
Contact your Öhlins dealer for advice.*

Öhlins shock absorber type 46 HRCS

Your new Öhlins shock absorber features the following adjustments:

- Compression damping adjustment
- Rebound damping adjustment
- Hydraulic spring preload adjustment

NOTE!

*Your new shock absorber is dialled-in to Öhlins recommended settings.
If you have "played" with the adjusters, please check the setting.*

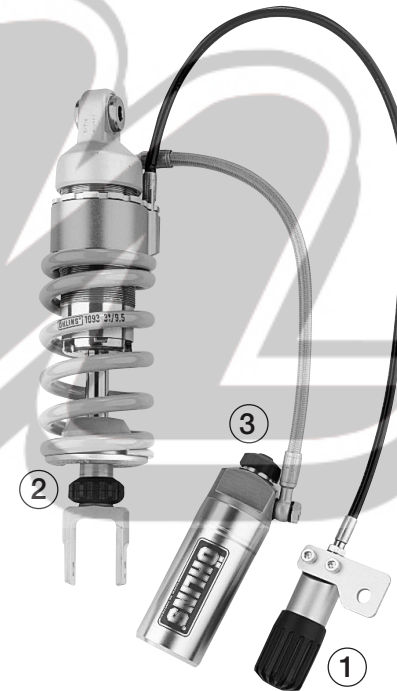

The adjusters have a normal right-hand thread. On the compression and the rebound damping adjusters, click position zero (0) is when the adjusters are turned clockwise (in) to fully closed. Using too much force when closing the adjusters will destroy important sealing surfaces. Turn counter clockwise (out) to open and count the clicks until you reach the recommended number of clicks. See "Setup data" at page 4. With the adjusters you optimize the suspension for your riding style and the track you are racing at. For details see the "Owners manual".

Spring preload adjuster

Adjustments are made by turning the knob on the hydraulic adjuster. Clockwise for harder adjustment, counter clockwise to release the preload.

- 1 Spring preload adjuster**
Adjustments are made by turning the knob on the hydraulic adjuster.
- 2 Rebound damping adjuster**
When adjusting use no tools, simply your fingers
- 3 Compression damping adjuster**



Öhlins Racing AB, Box 722, S-194 27 Upplands Väsby, Sweden.
Phone +46 8 590 025 00. Fax +46 8 590 025 80.

www.ohlins.com

Part No.HO 801. Issued 02 11 11

© Öhlins Racing AB. All rights reserved. Any reprinting or unauthorized use without the written permission of Öhlins Racing AB is prohibited. Printed in Sweden.



Safety signals

Important information concerning safety is distinguished in this manual by the following notations:



**The Safety alert symbol means:
Caution! Your safety is involved.**

⚠ WARNING!

Failure to follow warning instructions could result in severe or fatal injury to anyone working with, inspecting or using the suspension, or to bystanders.

CAUTION!

Caution indicates that special precautions must be taken to avoid damage to the suspension.

NOTE!

This indicates information that is of importance with regard to procedures.

Before installation

Öhlins Racing AB can not be held responsible for any damage whatsoever to shock absorber or vehicle, or injury to persons, if the instructions for fitting and maintenance are not followed exactly.

Similarly, the warranty will become null and void if the instructions are not adhered to.

⚠ WARNING!

1. Installing a shock absorber, that is not approved by the vehicle manufacturer, may affect the stability of your vehicle. Öhlins Racing AB cannot be held responsible for any personal injury or damage whatsoever that may occur after fitting the shock absorber. Contact an Öhlins dealer or other qualified person for advice.

2. Please study and make certain that you fully understand all the mounting instructions and the owners manuals before handling this shock absorber kit. If you have any questions regarding proper installation procedures, contact an Öhlins dealer or other qualified person.

3. The vehicle service manual must be referred to when installing the Öhlins shock absorber

Öhlins products are subject to continual improvement and development. Consequently, although these instructions include the most up-to-date information available at the time of printing, there may be minor differences between your suspension and this manual. Please consult your Öhlins dealer if you have any questions with regard to the contents of the manual.

NOTE!

During storage and transportation, especially at high ambient temperature, the oil and grease used for assembling may run out inside the packing and damage the expanded polystyrene packing material. This is not unusual and is in no way detrimental to the shock absorber.

Kit contents

Before installing the shock absorber, please check the contents of the kit, listed on the front page of this instruction. If anything is missing, contact your Öhlins dealer.

Description	Pcs.	Part No.
Shock absorber 46 HRCS	1	HO 801
Hose clamp	2	00643-02
Rubber mounting	2	00230-03
Tie rap	4	00231-01
Screw M8x55	1	01046-27
Sticker Öhlins	2	00192-01
Memo sticker	1	01180-01
Owners manual	1	

Mounting instruction

1

Put the motorcycle on the centre stand. Remove the seat and rear cover.

⚠ WARNING!

1. It's advisable to have an Öhlins dealer or other qualified person to fit your shock absorber.
2. Instructions in the vehicle service manual are to be followed when changing the shock absorber.
3. When working on a lifted vehicle it must be securely supported to prevent it from falling.

2

Loosen the bolts to the rear subframe. Remove the lower bolts.

3

Loosen the chain guard

4

Remove the lower and upper shock absorber mounting bolts.

5

Lift the rear frame enough to make removal of the shock absorber rearwards possible.

6

Attach the Öhlins shock absorber in reverse order. The gas reservoir and the hydraulic preload adjuster should be pulled out to the right side of the motorcycle in front of the hose to the brake fluid reservoir.

7

Mount the upper and lower shock absorber bolts. Refit the rear subframe and bolts and fix the chain guard.

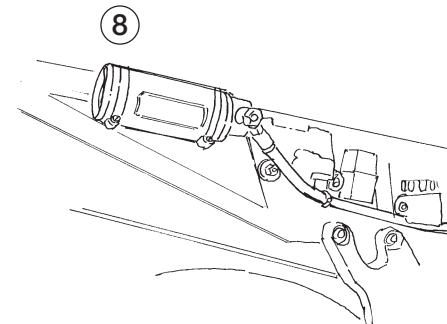

8

Mount the reservoir with the supplied mounting rubbers (00230-03) and hose clamps (00643-02) according to the sketch.

9

The hydraulic preload adjuster shall be mounted at the silencer bracket. Use the screw (01046-27) supplied.

10

Fix the hoses with the tie raps (00231-01).

11

Mount the seat and rear cover.

NOTE!

Make sure that all bolts are tightened to the correct torque and that nothing fouls or restricts movement of the shock absorber when the suspension is being fully compressed or extended.

12

Continue your work according to the Owners manual, section adjustments.

