

### 👁 Note!

Before installing this product, check the contents of the kit. If anything is missing, please contact an Öhlins dealer.

### Kit Contents

Description	Part No	Pcs
Shock absorber	HO427	2
Sticker Öhlins	00192-01	2
Sticker Öhlins	01185-01	1
Sticker Öhlins	01185-04	1
C-spanner	00710-01	1
Owner's manual	07241-02	1

### 👁 Note!

Please note that this image is a general representation of the product and may differ slightly from your product.

### 👁 Note!

Please note that during storage and transportation, especially at high ambient temperature, some of the oil and grease used for assembling may leak and stain the packaging. This is in no way detrimental to the product, wipe off the excessive oil/grease with a cloth.

### ⚠ Warning!

Before installing this product, read the Öhlins Owner's Manual. The shock absorber is an important part of your vehicle and will affect the stability.

## Shock Absorber for Honda PCX 150

# HO427

## Mounting Instructions



# MOUNTING INSTRUCTIONS

## **⚠ Warning!**

*It is advisable to have an Öhlins dealer install the shock absorber.*

## **⚠ Warning!**

*If working on a raised vehicle, ensure it is securely supported so that it will not tip over.*

## **👁 Note!**

*Before mounting this product clean the vehicle thoroughly.*

## **👁 Note!**

*When working on this product, always see the Vehicle Service Manual for vehicle specific procedures and important data.*

**1**

Put the motorcycle on the center stand so that the rear wheel barely touches the ground.

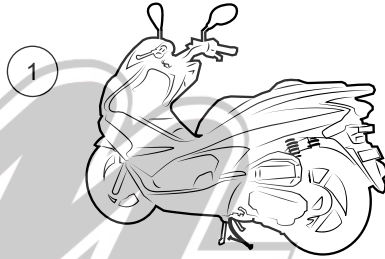

**2**

Open the seat and remove the groove by loosening two screws (1). Then loosen four bolts and loosen two screws (2).

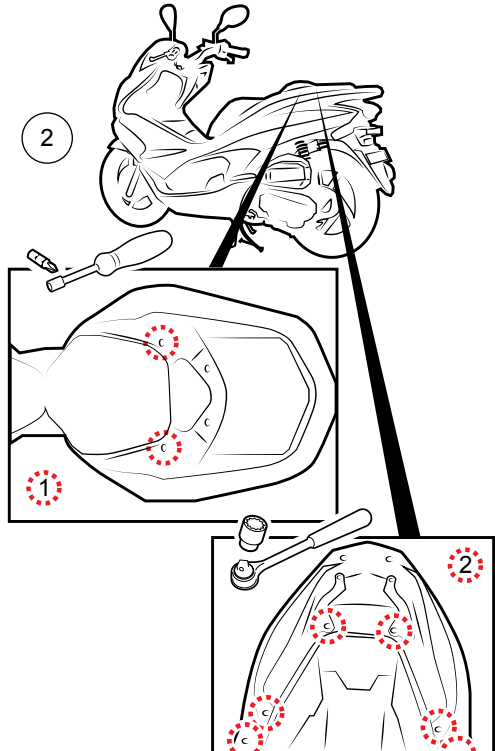

# MOUNTING INSTRUCTIONS

3

Remove the center compartment by loosening four bolts, then unlock the battery cover and loosen two nuts.

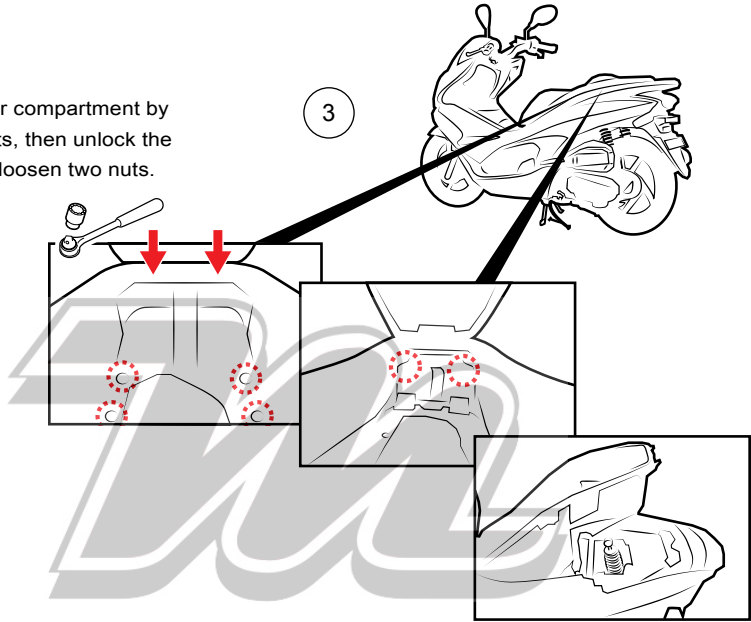

4

Remove the standard shock by loosening the upper nut then loosen the lower bolt. Install the Öhlins shock by pointing the cylinder head downward. Reverse all procedures above to reassembly the motorcycle.

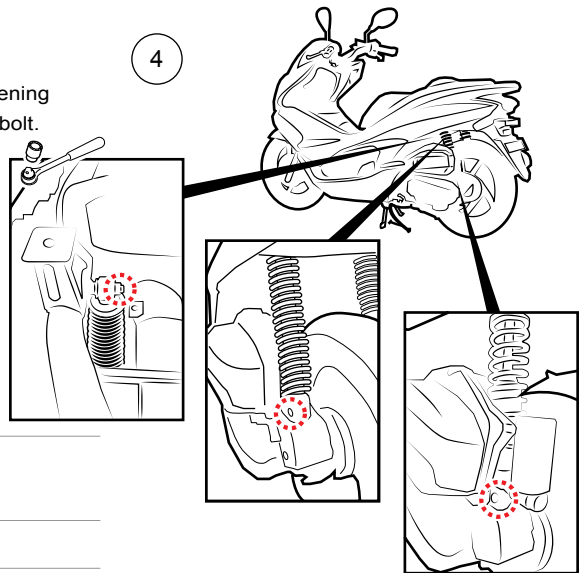

## **Note!**

Lower the vehicle so that the suspension is slightly compressed before tightening the screws.

## **Caution!**

Ensure that all screws are tightened to the correct torque and that nothing fouls or restricts movement of the shock absorber when the suspension is fully compressed or extended.

# ADJUSTMENTS

## ⚠ Warning!

Before riding, always make sure that the basic settings made by Öhlins are according to recommended Set-up Data. Read about adjustments and setting up in the Öhlins Owner's Manual before you make any adjustments. Contact an Öhlins dealer if you have any questions about setting up.

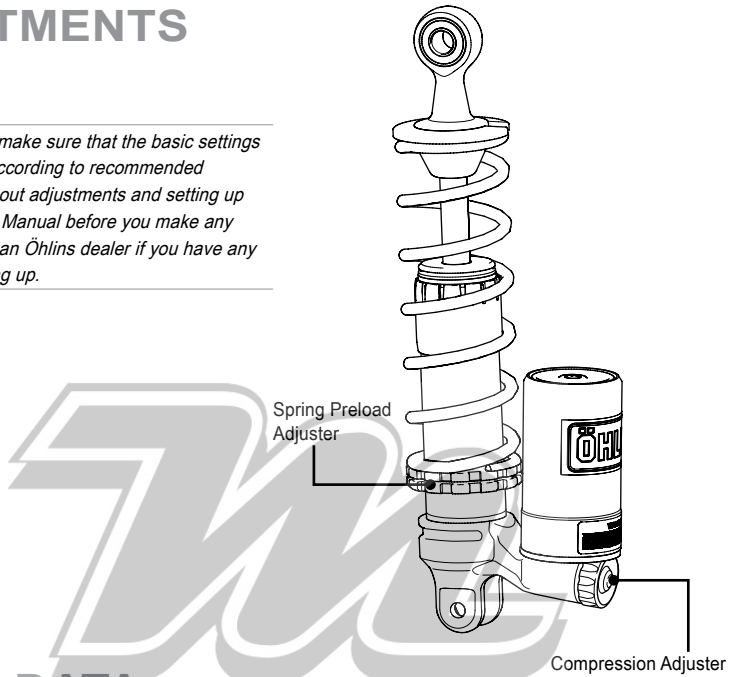

# SET-UP DATA

### Recommended set-up

Spring Preload ..... 15 mm  
Compression Adjuster ..... 12 clicks

### Shock absorber data

Length ..... 313 mm  
Stroke ..... 88 mm

### Spring

Part No ..... 60281-19  
Free spring length ..... 200 mm

👁 Öhlins products are subject to continuous improvement and development, therefore, although these instructions include the most up-to-date information available at the time of printing, minor updates may occur.

To find the latest information contact an Öhlins distributor. Please contact Öhlins if you have any questions regarding the contents in this document.

Part no. MI\_HO427\_EN\_1  
Issued 2014-10-22

© Öhlins Asia Co. Ltd. All rights reserved. Any reprinting or unauthorized use without the written permission of Öhlins Racing AB is prohibited.

Öhlins Asia Co. Ltd  
700/937 Moo5, Tambol Nongkhaga,  
Amphur Phantong, Chonburi Province  
20160 Thailand



[www.ohlins.com](http://www.ohlins.com)