

Checking Sag and Ride Height

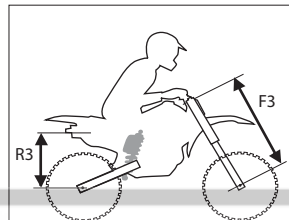
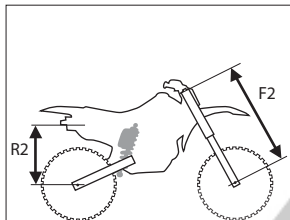
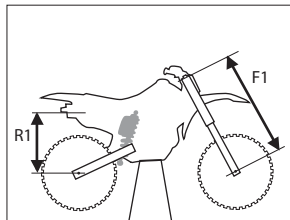

Front suspension

F1. Bike on a stand with the suspension fully extended	=	R1. Bike on a stand with the suspension fully extended	=
F2. Bike on the ground without rider	=	R2. Bike on the ground without rider	=
F3. Bike on the ground with rider	=	R3. Bike on the ground with rider	=
Free sag	F1 - F2 =	Free sag	R1 - R2 =
Ride height	F1 - F3 =	Ride height	R1 - R3 =

Rear suspension

Setup Data

Shock absorber length	245 mm
Shock absorber stroke	58 mm
Spring pre-load	6 mm
Free sag	20 ± 5 mm 3/4 ± 1/4 inch
Ride height	90 ± 5 mm 3 1/2 ± 1/4 inch
Compression damping adjuster	15 clicks

NOTE!

*If ride height is higher than recommended, softer spring/springs must be used.
If ride height is lower than recommended, harder spring/springs must be used.
Contact your Öhlins dealer for advice.*

Spring recommendation

Part nr	Description	Rate N/mm	Rider's weight		Shock options
			kg	Lb	
00281-23	Spring 46/125/35N/mm	35	60-70	132-154	HO 382
00281-12	Spring 46/125/40N/mm	40	70-80	154-176	HO 382
00281-19	Spring 46/125/50N/mm	50	80-90	176-198	HO 382
00281-13	Spring 46/125/60N/mm	60	90+	198+	HO 382

Öhlins products are subject to continuous improvement and development. All information in this manual is based on the latest product information available at the time of approval for publishing. Consequently, there may be minor differences between your suspension and the suspension in this manual. Please consult your Öhlins dealer if you have any questions regarding the contents of this manual.



Öhlins Racing AB, Box 722, S-194 27 Upplands Väsby, Sweden.
Phone +46 8 590 025 00. Fax +46 8 590 025 80.
www.ohlins.com

Mounting Instructions

Öhlins Shock Absorber Kit
HO 382 for Honda CRF 50

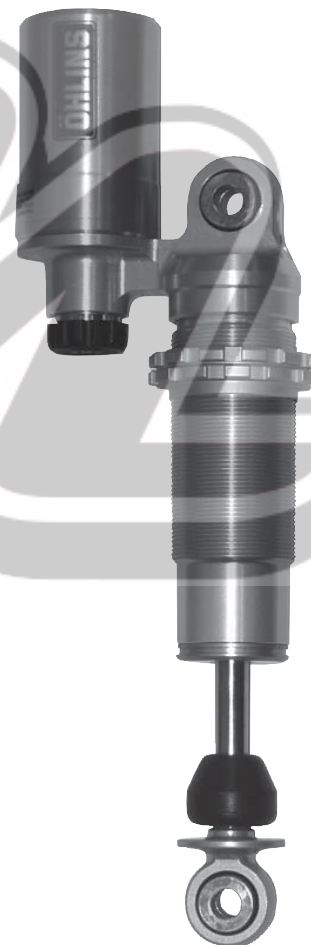

Kit Contents

Before installing the shock absorber, please check the contents of the kit. If anything is missing, please contact your Öhlins dealer.

Description	Pcs.	Part No.
Shock absorber 36 PCW	1	HO 382
C-spanner	1	00710-01
Spring clip	1	00116-01
Sticker Öhlins	2	00197-01
Owner's manual	1	

Before Installation

Öhlins Racing AB can not be held responsible for any damage to shock absorber or vehicle, or injury to persons, if the instructions for fitting and maintenance are not followed exactly.

Similarly, the warranty will become null and void if the instructions are not adhered to.

HO 382. Issued 05 08 15

© Öhlins Racing AB. All rights reserved. Any reprinting or unauthorized use without the written permission of Öhlins Racing AB is prohibited. Printed in Sweden.



Safety Signals

Important information concerning safety is distinguished in this manual by the following notations:



The Safety alert symbol means: Attention! Your safety is involved.

WARNING!

Failure to follow warning instructions could result in **severe or fatal injury** to anyone working with, inspecting or using the suspension, or to bystanders.

CAUTION!

Caution indicates that special precautions must be taken to avoid damage to the suspension.

NOTE!

This indicates information that is of importance with regard to procedures.

WARNING!

1. Installing a shock absorber, that is not approved by the vehicle manufacturer, may affect the stability of your vehicle. Öhlins Racing AB cannot be held responsible for any personal injury or damage that may occur after fitting the shock absorber. Contact an Öhlins dealer or other qualified person for advice.

2. Please study and make certain that you fully understand all the mounting instructions and the owner's manual before handling this shock absorber kit. If you have any questions regarding proper installation procedures, contact an Öhlins dealer or other qualified person.

3. The vehicle service manual must be referred to when installing the Öhlins shock absorber

NOTE!

During storage and transportation, especially at high ambient temperature, the oil and grease used for assembling may run out inside the packing and damage the expanded polystyrene packing material. This is not unusual and is in no way detrimental to the shock absorber.

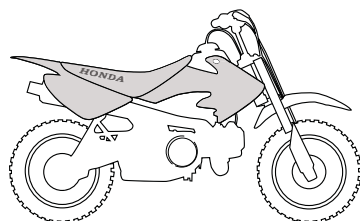
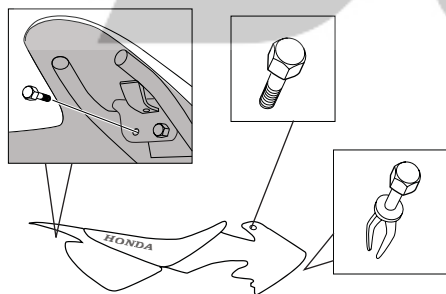

Mounting Instructions

WARNING!

1. It is advisable to have an Öhlins dealer or other qualified person to fit your shock absorber.
2. Instructions in the vehicle service manual are to be followed when changing the shock absorber.
3. When working on a lifted vehicle make sure it is securely supported to prevent it from falling.

1

Put the motorcycle on a stand so the rear wheel is clearly off the ground. Make sure it is steadily positioned and will not fall over.

2

Remove fairing and seat in one piece by removing the screws in the back (underneath the seat) on the sides and in the front (underneath the fairing). See figure.

3

Loosen and remove the original shock absorber. See the motorcycle's Workshop Manual.

4

Fit the Öhlins shock absorber in the same position as the original shock absorber.

5

Refit the seat and the fairing.

6

Check sag and ride height according to the Setup data on the last page of this manual. If your settings differ from the recommended, adjust according to the following description, (also, see figure to the right):

Spring pre-load adjuster

Turn the rings on the shock absorber body using a C-spanner. Clockwise for harder adjustment, counter clockwise to release the pre-load.

Compression damping adjuster

Adjustments are made on the slotted centre screw located under the reservoir.

NOTE!

When delivered the Öhlins shock absorber is dialed to recommended settings for the specific brand and make of the vehicle. If you have changed the settings, check like this:

The adjusters have a normal right hand thread. Turn the damping adjusters clockwise to fully closed (pos. zero [0]). Turn counter clockwise to open and count the clicks until you reach the recommended number of clicks. See Setup data at last page.

CAUTION!

Do not use too much force, delicate sealing surfaces can be damaged.

7

Continue your work according to the Owner's Manual, General settings.

Figure:
Öhlins shock absorber type 36 PCW adjusters

