

Kit Contents

| Description | Part No | Pcs |
|----------------------|----------|-----|
| Shock absorber | HO340 | 1 |
| Sticker Memo notes | 01180-01 | 1 |
| Sticker Öhlins wh/tr | 01185-01 | 2 |
| Sticker Öhlins bl/tr | 01185-04 | 2 |
| Screw M10 | 01239-05 | 1 |
| Owner's manual | 07242-05 | 1 |

👁 Note!

Please note that there can be small differences between your product and the images in these instructions.

👁 Note!

Please note that during storage and transport, especially at high ambient temperature, some of the oil and grease used for assembly may leak and stain the packaging. This will not cause damage to the product, wipe off the excessive oil or grease with a cloth.

👁 Note!

Before you install this product, check the kit contents. If anything is missing, please contact an Öhlins dealer.

⚠ Warning!

Before you install this product, read the Öhlins Owner's manual. This product is an important part of the vehicle and the vehicle stability.

Shock absorber for Honda CBR 1000 RR

HO 340

Mounting Instructions

MOUNTING INSTRUCTIONS

⚠ Warning!

We strongly recommend to let an Öhlins dealer install this product.

⚠ Warning!

If you work with a lifted vehicle, make sure that it is safely supported to prevent it from tipping over.

👁 Note!

When you work with this product, see the vehicle service manual for vehicle specific procedures and important data.

👁 Note!

Before you install this product clean the vehicle.

1

Put the motorcycle on a work stand so that the rear wheel barely touches the ground.

2

Remove the fairing screw at the bottom.

3

Remove the lambda cable clip from the frame.

4

Remove the exup cable behind the rear brake fluid reservoir.

5

Be careful with the lambda and the exup cable. Loosen and move the silencer to the right.

6

Remove the shock absorber screws and the link screw from the swing arm.

7

Remove the original shock absorber.

8

Install the Öhlins shock absorber.

9

Remove the lower left rear sub frame screw. Use the screw provided in this kit and install the hydraulic preload adjuster on the inside. Rotate the adjuster up as much as possible before you tighten the nut.

10

Install all removed parts in the same positions that they were before removal.

👁 Note!

Lower the vehicle so that the suspension is slightly compressed before you tighten the screws.

👉 Caution!

Make sure that you tighten all screws to the correct torque and that nothing fouls or restricts movement of the shock absorber/front fork/steering damper when the suspension is fully compressed or extended.

MOUNTING INSTRUCTIONS

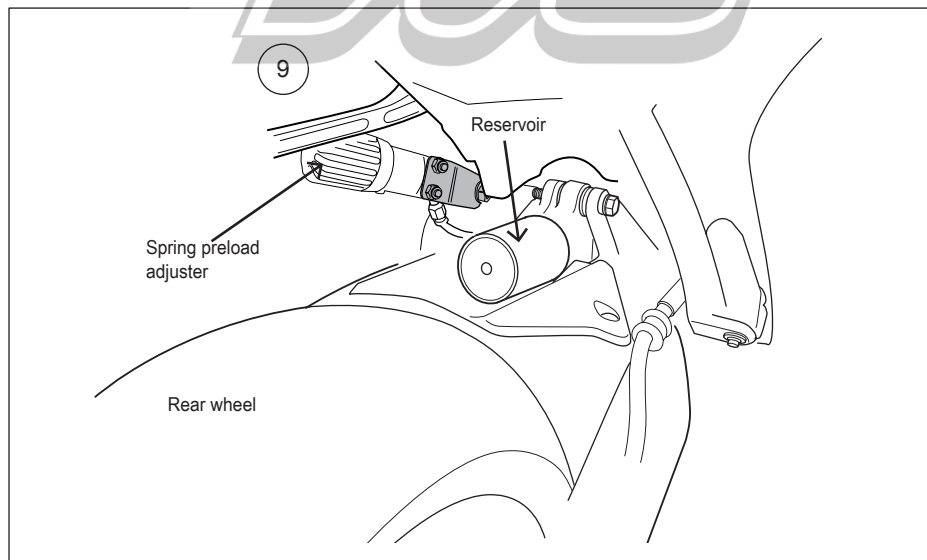
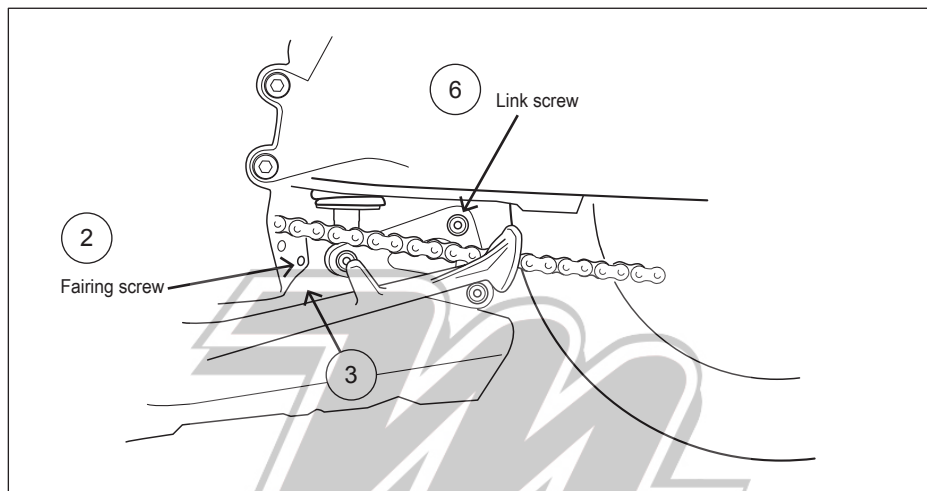

ADJUSTMENTS

⚠ Warning!

Before you ride/drive, always make sure that the setup is according to the recommended setup data. Read about adjustments and setting up in the Öhlins Owner's Manual before you make any adjustments. Contact an Öhlins dealer if you have any questions about setting up.

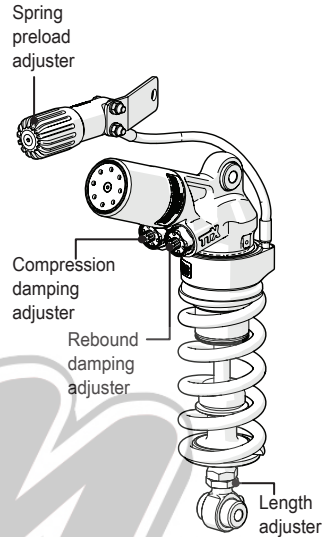

SETUP DATA

| | | |
|--------------------|-----------|--------|
| Length | 302 +4/-2 | mm |
| Stroke | 60 | mm |
| Rebound | 13 | clicks |
| Compression | 10 | clicks |
| Spring preload | 14 | mm |
| Spring | 21040-36 | |
| Spring rate | 105 | N/mm |
| Spring free length | 160 | mm |

| Recommended sag and ride height | | |
|---------------------------------|----|----|
| R1-R3 | 32 | mm |
| F1-F3 | 41 | mm |

Öhlins products are subject to continuous improvement and development, therefore, although these instructions include the most up-to-date information available at the time of printing, minor updates may occur.

To find the latest information contact an Öhlins distributor. Please contact Öhlins if you have any questions regarding the contents in this document.

Part no. MI_HO340_1
Issued 2014-02-20

© Öhlins Racing AB. All rights reserved. Any reprinting or unauthorized use without the written permission of Öhlins Racing AB is prohibited.

Öhlins Racing AB
Box 722
S-194 27 Upplands Väsby, Sweden
Phone +46 8 590 025 00
fax +46 8 590 025 80



www.ohlins.com