

Before installing this product, check the contents of the kit. If anything is missing, please contact your nearest Öhlins dealer.

Kit Contents

	Part No.	Pcs.
Shock absorber	HO 1690	1
Spring clip	00629-01	1
Öhlins Sticker	10207-01	1
Owner's manual	07251-02	1

Please note that during storage and transportation, especially at high ambient temperature, some of the oil and grease used for assembling may leak and stain the packaging. This is in no way detrimental to the product, wipe off the excessive oil/grease with a cloth.

⚠ Warning!

Before installing this product, read the Öhlins Owner's Manual. The shock absorber is an important part of your vehicle and will affect the stability.

Shock Absorber for Honda CRF150R

HO 1690

Mounting Instructions



Spring Guide

Brand	Rider's weight*	Spring	Spring rate
	kg/pounds		N/mm
Honda CRF150	<45/99	00698-09	50
	<50/110	00698-10	52
	<55/121	00698-11	54
	<65/143	00698-13	58

* Rider's weight: Rider wearing all riding equipment

Install the Spring

👁️ **Note!**

Install the spring to the shock absorber before installing the shock absorber on the vehicle.

- 1**
Measure the free length of the spring (A).
- 2**
Loosen the screw on the spring platform clamp so that you can move the spring platform as far up as needed to install the spring.
- 3**
Put the shock absorber up-side-down in a vice so that you can install the spring and the spring clip.

👁️ **Note!**

The spring platform and spring are press fitted. Push hard to install the spring.

- 4**
Measure the spring length. Adjust the spring preload to the recommended setting, see section *Adjustments* and *Set-up data* in this folder.
- 5**
Install the shock absorber to the vehicle according to the procedure in this folder.
Check sag and ride height (see the Owner's Manual) and adjust the spring preload again if necessary.

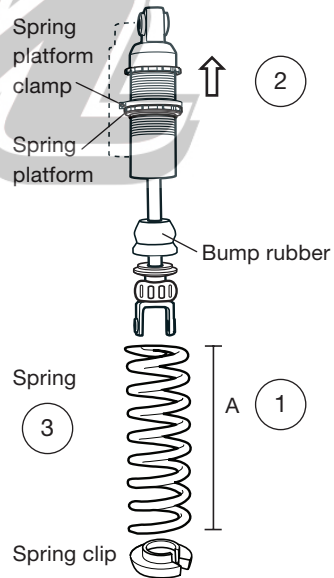

👁️ **Note!**

Tighten the preload lock nut before riding the motorcycle.

⚠ Warning!

It is advisable to have an Öhlins dealer install the shock absorber.

⚠ Warning!

When working on a raised vehicle, make sure the vehicle is securely supported so that it will not tip.

When installing, consult your Vehicle Service Manual.

VEHICLE
SERVICE
MANUAL

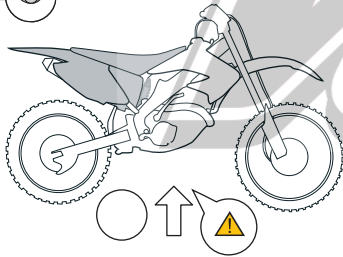

1

Install the Öhlins shock absorber according to the vehicle manual. Use original attachment screws.

👁 Note!

Before installing the Öhlins shock absorber clean the vehicle thoroughly.

2

Make sure that all removed parts are reinstalled in the same way as they were before the installation of the Öhlins shock absorber.

👉 Caution!

Make sure that all screws are tightened to the correct torque and that nothing fouls or restricts movement of the shock absorber when the suspension is fully compressed or extended.

⚠ After installing this product, take a test ride at low speed to make sure that your vehicle has maintained its stability.

⚠ If the suspension makes an abnormal noise, or the function is irregular, or if you notice any leakage from the product, please stop the vehicle immediately and return the product to an Öhlins Service Centre.

Set-up Data

Recommended set-up

Rebound	25 clicks
Compression, low	12 clicks
Compression, high	II

Shock absorber data

Length	427 mm
Stroke	104 mm

Free Sag and Ride Height

R1-R2	30±5 mm
R1-R3	75±5 mm

👁️ Read more about free sag and ride height in the Öhlins Owner's Manual.

Adjustments

⚠️ Warning!

Before riding, always make sure that the basic settings made by Öhlins are according to recommended Set-up Data. Read about adjustments and setting up in the Öhlins Owner's Manual before you make any adjustments. Contact an Öhlins dealer if you have any questions about setting up the shock absorber.

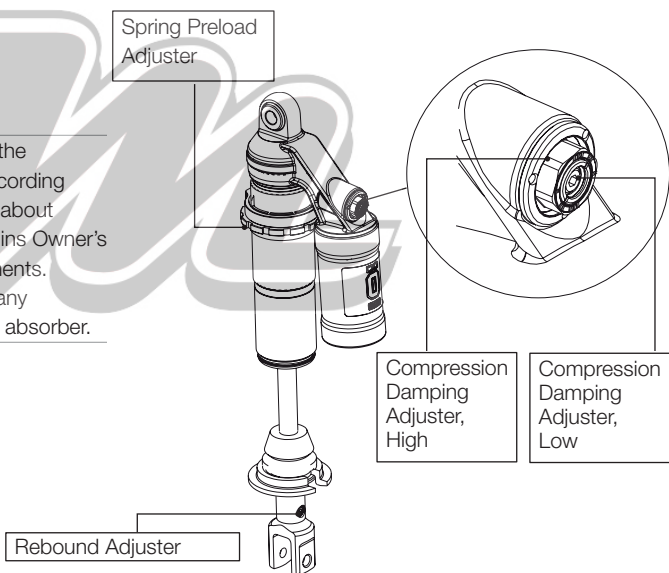

👁️ Öhlins products are subject to continuous improvement and development, therefore, although these instructions include the most up-to-date information available at the time of printing, minor updates may occur.

To find the latest information contact your Öhlins distributor. Please consult your Öhlins dealer if you have any questions regarding the contents in this document.

Part no. HO1690_0
Issued 2015-11-18

© Öhlins Racing AB. All rights reserved. Any reprinting or unauthorized use without the written permission of Öhlins Racing AB is prohibited.

Öhlins Racing AB
Box 722
S-194 27 Upplands Väsby, Sweden
Phone +46 8 590 025 00
fax +46 8 590 025 80



www.ohlins.com