

Adjustments

⚠ Warning!

Before riding, always make sure that the basic settings made by Öhlins are according to recommended Set-up Data. Read about adjustments and setting up in the Öhlins Owner's Manual before you make any adjustments. Contact an Öhlins dealer if you have any questions about setting up the shock absorber.

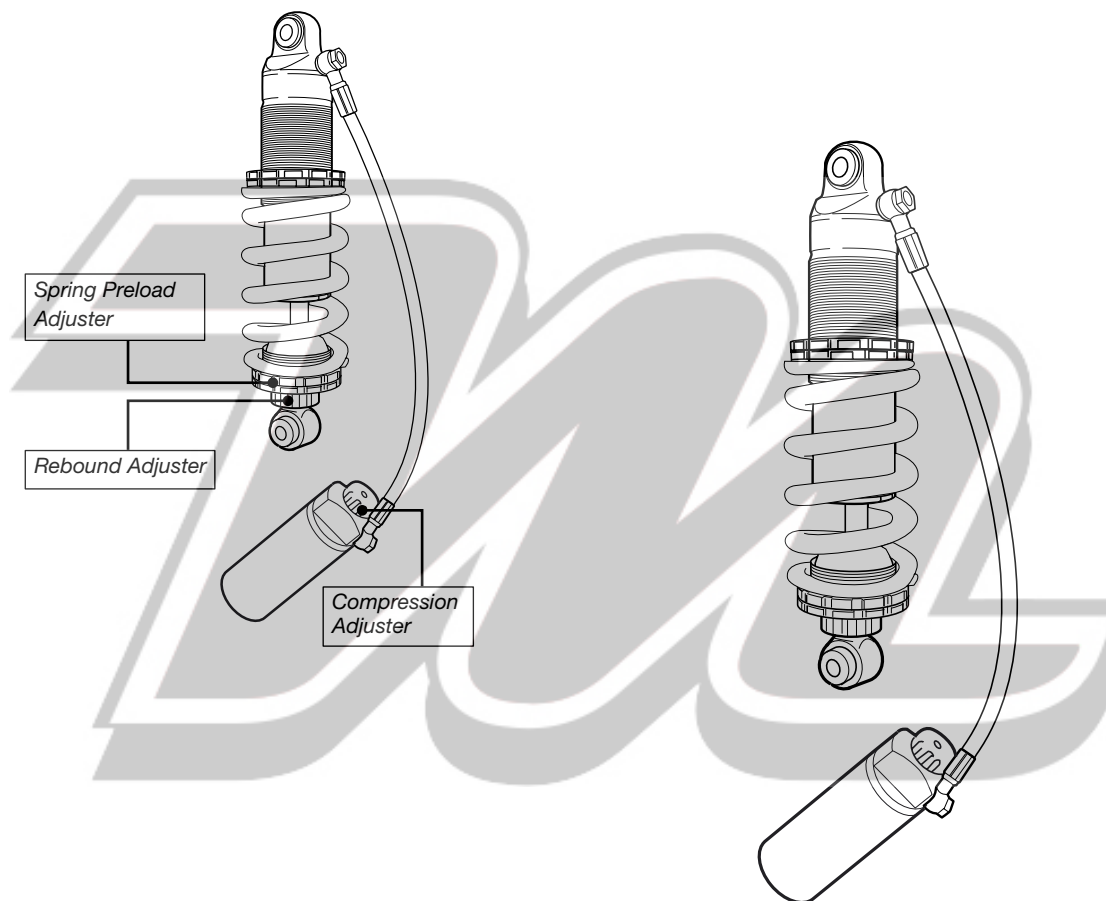

Set-up Data

Spring preload 10 mm
Compression damping 14 clicks
Rebound damping 16 clicks

Shock absorber length 307.5 mm
Stroke 50.5 mm

Spring part no. 01093-64
Free spring length 150 mm
(160N/mm)

Before installing this product, check the contents of the kit. If anything is missing, please contact an Öhlins dealer.

Kit Contents

	Part No.	Pcs.
Shock absorber	HO 107	1
Washer	00153-03	2
Nut M5	00430-04	3
Screw MC6S 5x16	01046-18	2
Screw MC6S 5x22	01046-26	1
Spacer	01166-01	1
Screw MC6S 6x30	01046-02	1
Bracket hydr. prel.	01165-10	1
Reservoir bracket	05378-10	1
C-spanner single	00710-02	1
Öhlins Sticker	00192-01	2
Memo Notes Sticker	01180-01	1
Owner's Manual	07241-02	1

⚠ Warning!

Before installing this product, read the Öhlins Owner's Manual. The shock absorber is an important part of your vehicle and may affect the stability of your vehicle.

Please note that during storage and transportation, especially at high ambient temperature, some of the oil and grease used for assembling may leak and stain the packaging. This is in no way detrimental to the product, wipe off the excessive oil/grease with a cloth.

Öhlins products are subject to continuous improvement and development, therefore, although these instructions include the most up-to-date information available at the time of printing, minor updates may occur.

To find the latest information contact your Öhlins distributor. Please consult your Öhlins dealer if you have any questions regarding the contents in this document.

Part no. HO107_0
Issued 2011-06-29



Shock Absorber for Honda Hornet CB 600F and CBR 600F

HO 107

Mounting Instructions

© Öhlins Racing AB. All rights reserved. Any reprinting or unauthorized use without the written permission of Öhlins Racing AB is prohibited.

Öhlins Racing AB
Box 722
S-194 27 Upplands Väsby, Sweden
Phone +46 8 590 025 00
fax +46 8 590 025 80



www.ohlins.com



⚠ Warning!

It is advisable to have an Öhlins dealer install the shock absorber.

When installing, consult your Vehicle Service Manual.

⚠ Warning!

Make sure the vehicle is securely supported so that it will not tip.

1
Put the motorcycle on a workstand so that the rear wheel barely touches the ground.

2
Remove the seat and side covers.

3
Loosen the brake fluid reservoir.

4
Remove the original shock absorber. *Consult your Vehicle Service Manual.*

👁 Note!

Recommendation: Before installing the Öhlins shock absorber clean the vehicle thoroughly.

5
Install the Öhlins shock absorber with the reservoir on the right side of the bike. Use the original attachment bolts, do not tighten yet.

👁 Note!

Lower the motorcycle so that the shock absorber is slightly compressed, before tightening the screws.

6
Tighten the shock absorber bolts to the correct torque according to the Honda specs.

7

Install the reservoir on the right side with the brackets and screws provided in this kit, according to the sketch.

For Honda Hornet CB 600F and CBR 600F from model year 2011;

Mount spacer (part no 01166-01) and screw (part no 01046-02) according to figure.

👁 Caution!

Make sure that all screws are tightened to the correct torque and that nothing fouls or restricts movement of the shock absorber when the suspension is fully compressed or extended.

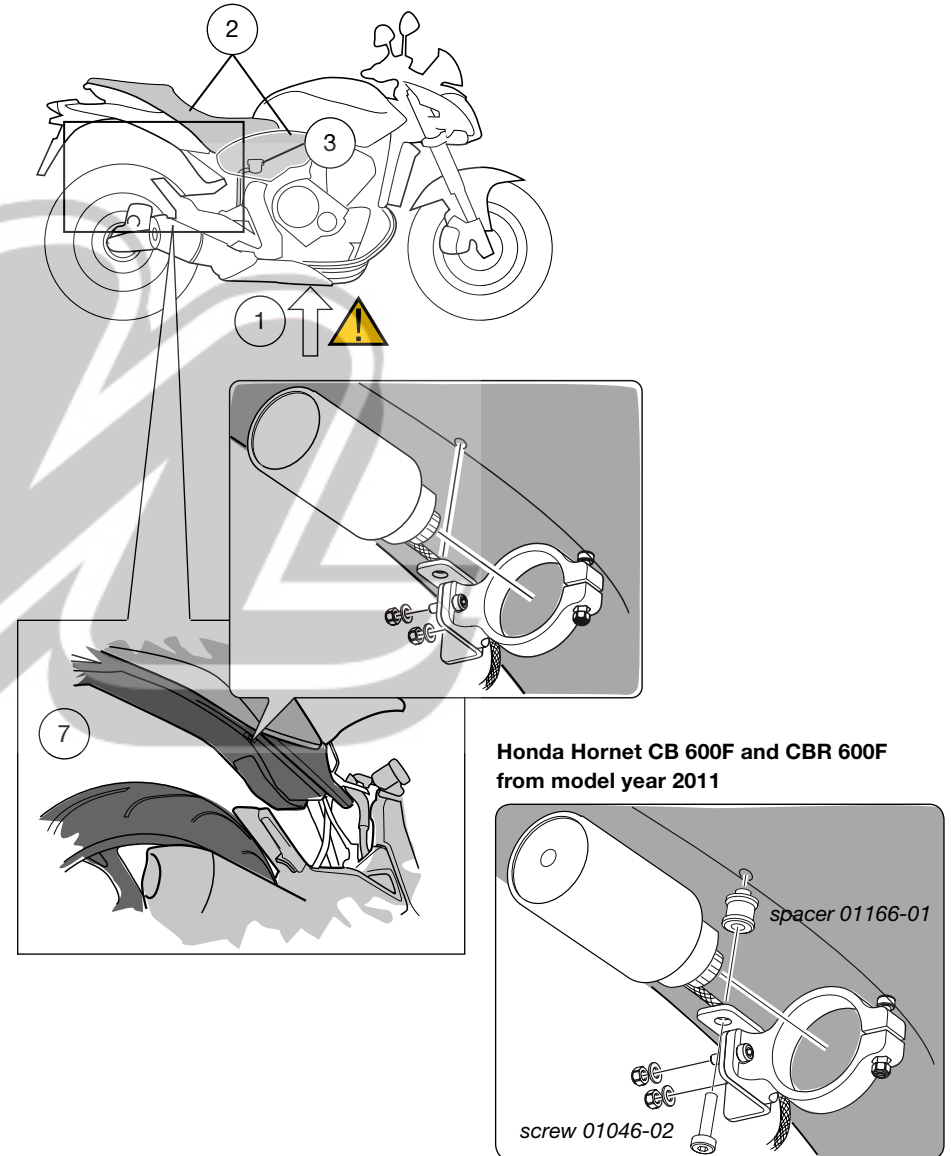

Honda Hornet CB 600F and CBR 600F from model year 2011