

8

Fit the hydraulic spanner adjustment to the silencer bracket. Use the bolt provided (M8x50). Use tie raps to fix the hose.

NOTE!

Make sure that all bolts are tightened to the correct torque and that nothing fouls the shock absorber when the suspension is being fully compressed or extended.

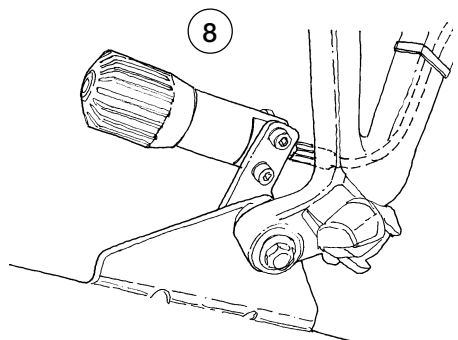

9

Continue your work according to the Owner's Manual, section adjustments.

WARNING!

This particular model has an adjustable end eye. The eye must not be screwed out more than that the groove is fully visible beneath the lock nut. Make sure that the lock nut is tightened after adjustment.

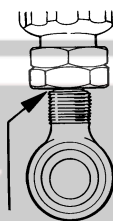

Groove

Mounting instructions

HO 049 – HONDA CBR 600 F/S

Kit contents

Shock absorber Type 46PRCLS	HO 049	1
Bolt M8x50	1046-25	1
Tie rap	231-01	2
Sticker Öhlins	192-01	2
Sticker Memo note	1180-01	1
Owners Manual	7240-01	1

Set-up data

Length	306 mm (+12/-0 mm)
Stroke	54 mm
Rebound adjustment	12 clicks
Compression adjustment	12 clicks
Preload	15 mm

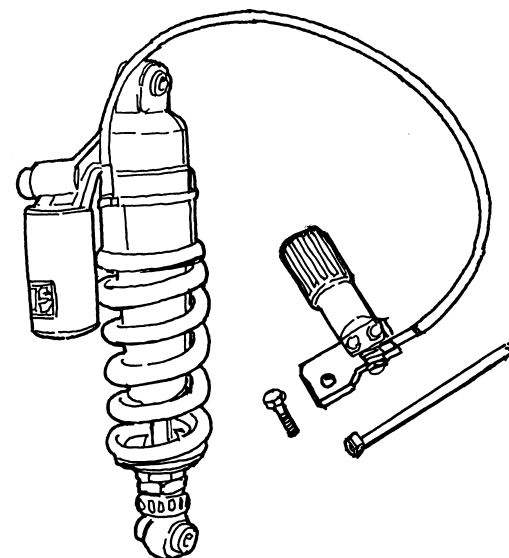

Öhlins Racing AB, Box 722, S-194 27 Upplands Väsby, Sweden.
Phone +46 8 590 025 00, fax +46 8 590 025 80.
E-mail: info@ohlins.se
www.ohlins.com

HO 049, ISSUED 01 03 15



Safety signals

Important information concerning safety is distinguished in this manual by the following notations.



The Safety alert symbol means: **Caution! Your safety is involved.**

WARNING!

Failure to follow warning instructions could result in **severe or fatal injury** to anyone working with, inspecting or using the suspension, or to bystanders.

CAUTION!

Caution indicates that special precautions must be taken to avoid damage to the suspension.

NOTE!

This indicates information that is of importance with regard to procedures.

Kit contents

Before installing the shock absorber, please check the contents of the kit, listed on the front page of this instruction. If anything is missing, contact your Öhlins dealer.

NOTE!

During storage and transportation, especially at high ambient temperature, the oil and grease used for assembling may run out inside the packing and damage the expanded polystyrene packing material. This is not unusual and is in no way detrimental to the shock absorber.

Before you start

WARNING!

Installing a shock absorber, that is not approved by the vehicle manufacturer, may affect the stability of your vehicle. Öhlins Racing AB cannot be held responsible for any personal injury or damage whatsoever that may occur after fitting the shock absorber. Contact an Öhlins dealer or other qualified person for advice.

Öhlins Racing AB can not be held responsible for any damage whatsoever to shock absorber or vehicle, or injury to persons, if the instructions for fitting and maintenance are not followed exactly. Similarly, the warranty will become null and void if the instructions are not adhered to.

WARNING!

Please study and make certain that you fully understand all the mounting instructions and the owner's manuals before handling this shock absorber kit. If you have any questions regarding proper installation procedures, contact an Öhlins dealer or other qualified person.

WARNING!

The vehicle service manual must be referred to when installing the Öhlins shock absorber.

NOTE!

Öhlins products are subject to continual improvement and development. Consequently, although these instructions include the most up-to-date information available at the time of printing, there may be minor differences between your suspension and this manual. Please consult your Öhlins dealer if you have any questions with regard to the contents of the manual.

Mounting instruction

1

Put the motorcycle on a stand so the rear wheel is of the ground. Make sure it's steadily positioned and will not fall over. The center stand is excellent if it is risen a few inches.

WARNING!

1. It's advisable to have an Öhlins dealer or other qualified person to fit your shock absorber.
2. Instructions in the motorcycle workshop manual are to be followed when changing the shock absorber.
3. When working on the motorcycle it must be securely supported to prevent it from falling over.

2

Unlock the seat and remove it.

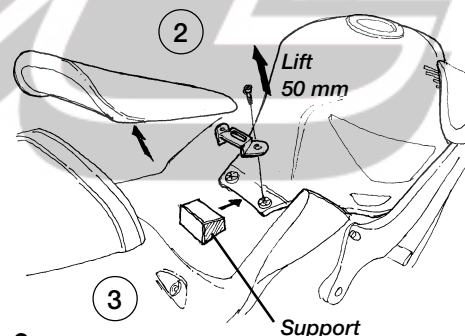

3

Loosen the bolts for the rear gas tank bracket according to the picture. Lift it up around 50 mm and put a support in between to hold the rear end of the tank. Loosen the reservoir for the standard shock absorber.

4

Remove the upper and lower shock absorber mounting bolts.

NOTE!

The upper bolt can be easily reached if the back of the gasoline tank is lifted up.

5

Remove the shock absorber backwards and out on the left side of the motorcycle.

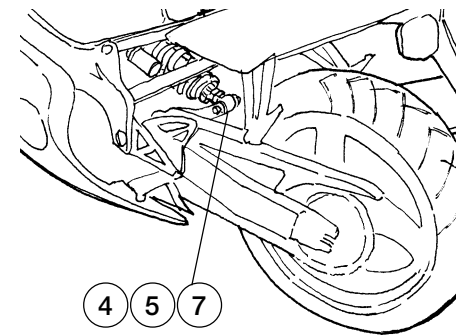

6

Loosen the cables inside the left side of the rear frame and turn them to the top of the frame secure them with tie raps.

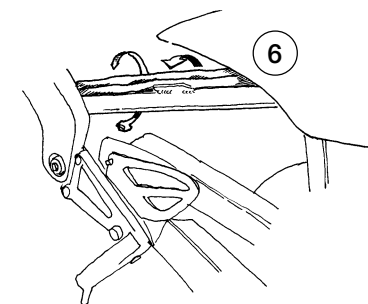

7

Fit the Öhlins shock absorber by positioning it from the rear. Fit the upper bracket first and then the lower bracket.

© Öhlins Racing AB.
All rights reserved.

Any reprinting or unauthorized use without the written permission of Öhlins Racing AB is prohibited.
Printed in Sweden.