

Adjustments

⚠ Warning!

Before riding, always make sure that the basic settings made by Öhlins are according to recommended Set-up Data. Read about adjustments and setting up in the Öhlins Owner's Manual before you make any adjustments. Contact an Öhlins dealer if you have any questions about setting up the shock absorber.

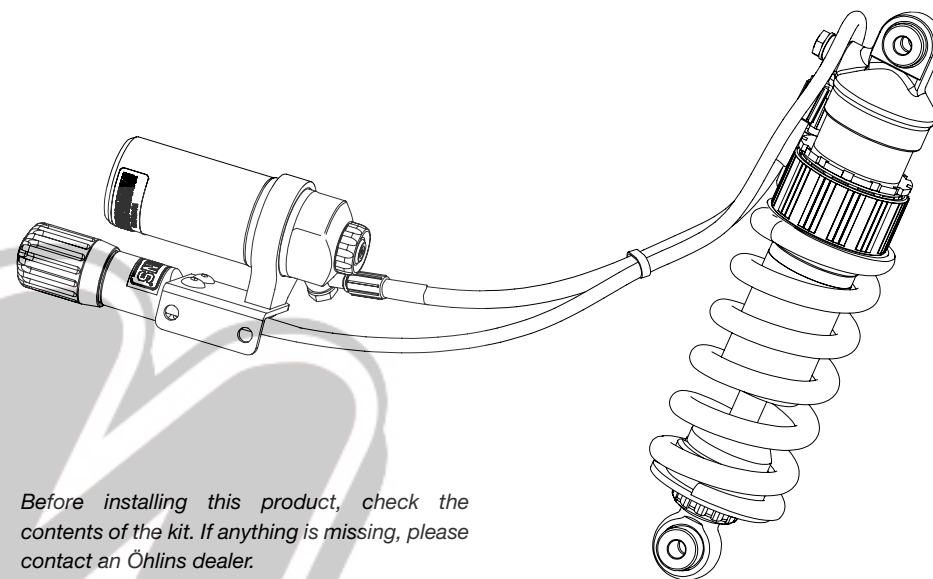
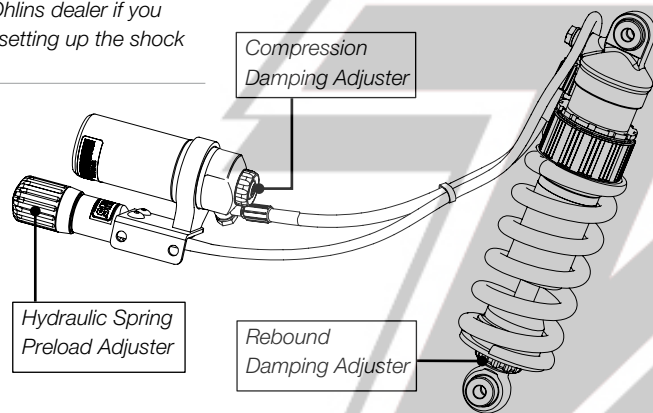

Set-up Data

Recommended set-up

Rebound	18 clicks
Compression	12 clicks
Spring Preload	10 mm
Spring	
Part No.	01092-91
Spring, Rate	230 mm
Spring, free length	170 mm

Shock absorber data

Length	311,5 mm
Stroke	44,5

Free Sag and Ride Height

R1 - R2 =	10 mm
R1 - R3 =	29 mm

Before installing this product, check the contents of the kit. If anything is missing, please contact an Öhlins dealer.

Kit Contents	Part No.	Pcs.
Shock absorber	HO015	1
Screw K6S M6x12	05404-01	2
Screw K6S M6x30	05404-07	2
Washer 6.4/12/1.5	00153-04	6
Nut M6	00430-02	2
Tie wrap	00231-01	2
Screw	00382-16	1
Bracket	03102-05	1
Bracket	21617-07	1
Öhlins Sticker	00192-01	2
Memo Notes Sticker	01180-01	1
Owner's Manual	07241-02	1

Please note that during storage and transportation, especially at high ambient temperature, some of the oil and grease used for assembling may leak and stain the packaging. This is in no way detrimental to the product, wipe off the excessive oil/grease with a cloth.

⚠ Warning!

Before installing this product, read the Öhlins Owner's Manual. The shock absorber is an important part of your vehicle and will affect the stability.

Öhlins products are subject to continuous improvement and development, therefore, although these instructions include the most up-to-date information available at the time of printing, minor updates may occur.

To find the latest information contact your Öhlins distributor. Please consult your Öhlins dealer if you have any questions regarding the contents in this document.

Part no. HO015_0
Issued 2010-05-25



Shock Absorber for Honda CBF 1000F HO 015

Mounting Instructions

© Öhlins Racing AB. All rights reserved. Any reprinting or unauthorized use without the written permission of Öhlins Racing AB is prohibited.

Öhlins Racing AB
Box 722
S-194 27 Upplands Väsby, Sweden
Phone +46 8 590 025 00
fax +46 8 590 025 80



www.ohlins.com



⚠ Warning!

It is advisable to have an Öhlins dealer install the shock absorber.

When installing, consult your Vehicle Service Manual.

1
Put the motorcycle on a workstand so that the rear wheel barely touches the ground.

⚠ Warning!

Make sure the vehicle is securely supported so that it will not tip.

2
Remove seat and the covers on the right and left side of the vehicle.

3
Loosen upper and lower attachment of the original shock absorber and remove it.

👁 Note!

Before installing the Öhlins shock absorber clean the vehicle thoroughly.

4
Mount the Öhlins shock absorber from the right side. Mount it with the hose calliper pointing backwards.

👁 Note!

Lower the motorcycle so that the shock absorber is slightly compressed, before tightening the screws.

5
Loosen the bolts on the right side passenger foot peg.

6
Use the provided screws and nuts, install the bracket together with the reservoir and spring preload adjuster on the foot peg.

7
Use two tie wrap (provided in this kit) to position the hoses together in soft bends. Position the upper tie wrap around the bracket together with the two hoses.

👁 Caution!

Ensure that the hydraulic preload adjuster hose runs in soft bends. Also check that it does not come in contact with the exhaust pipe or any sharp edges.

8
Reinstall covers and seats.

👁 Caution!

Make sure that all screws are tightened to the correct torque and that nothing fouls or restricts movement of the shock absorber when the suspension is fully compressed or extended.

