

Adjustments

⚠ Warning!

Before riding, always make sure that the basic settings made by Öhlins are according to recommended Set-up Data. Read about adjustments and setting up in the Öhlins Owner's Manual before you make any adjustments. Contact an Öhlins dealer if you have any questions about setting up the shock absorber.

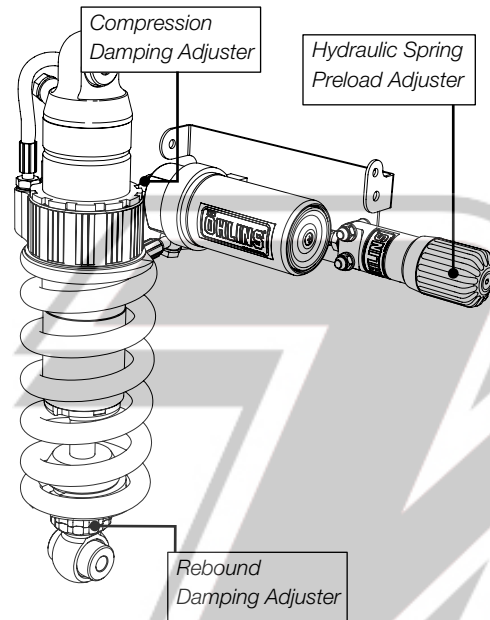

Set-up Data

Recommended set-up

Rebound	18 clicks
Compression	12 clicks
Spring Preload	13 mm
Spring	
Part No.	01092-74
Rate	180 N/mm
Spring, free length	170 mm

Shock absorber data

Length	321,5 mm
Stroke	50,5 mm

Free Sag and Ride Height

R1 - R2 =	16 mm
R1 - R3 =	38 mm

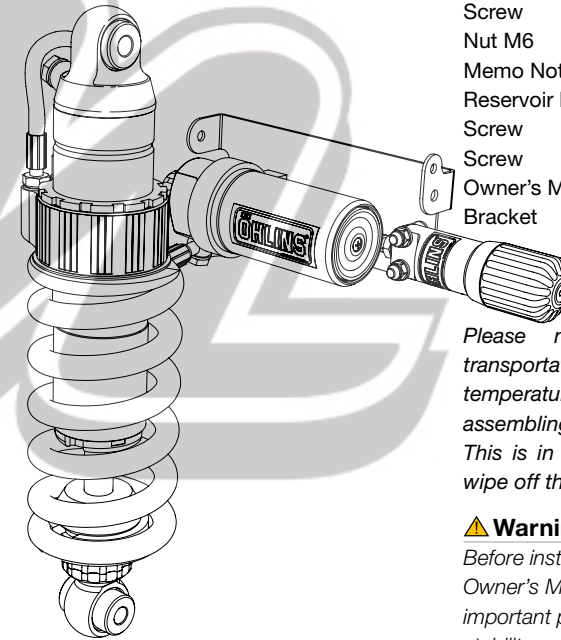

Before installing this product, check the contents of the kit. If anything is missing, please contact an Öhlins dealer.

Kit Contents

	Part No.	Pcs.
Shock absorber	HO013	1
Washer	00153-04	4
Öhlins Sticker	00192-01	2
Tie wrap	00231-01	2
Screw	00382-16	1
Nut M6	00430-02	2
Memo Notes Sticker	01180-01	1
Reservoir bracket	03102-05	1
Screw	05404-06	2
Screw	05404-01	2
Owner's Manual	07241-02	1
Bracket	21617-06	1

Please note that during storage and transportation, especially at high ambient temperature, some of the oil and grease used for assembling may leak and stain the packaging. This is in no way detrimental to the product, wipe off the excessive oil/grease with a cloth.

⚠ Warning!

Before installing this product, read the Öhlins Owner's Manual. The shock absorber is an important part of your vehicle and will affect the stability.

Öhlins products are subject to continuous improvement and development, therefore, although these instructions include the most up-to-date information available at the time of printing, minor updates may occur.

To find the latest information contact your Öhlins distributor. Please consult your Öhlins dealer if you have any questions regarding the contents in this document.

Part no. HO013_0
Issued 2010-06-01



Shock Absorber for Honda VFR 1200 F HO 013

Mounting Instructions

© Öhlins Racing AB. All rights reserved. Any reprinting or unauthorized use without the written permission of Öhlins Racing AB is prohibited.

Öhlins Racing AB
Box 722
S-194 27 Upplands Väsby, Sweden
Phone +46 8 590 025 00
fax +46 8 590 025 80



www.ohlins.com



How to install

⚠ Warning!

It is advisable to have an Öhlins dealer install the shock absorber.

When installing, consult your Vehicle Service Manual.

1

Put the motorcycle on a workstand so that the rear wheel barely touches the ground.

⚠ Warning!

Make sure the vehicle is securely supported so that it will not tip.

2

Remove seat and the covers on the right and left side of the fuel tank.

3

Remove the bolts that hold the tank in front. Loosen bolt in the back of the tank.

4

Lift the tank in front and remove the upper attachment of the original shock absorber.

5

Remove the preload adjuster together with the bracket (left side). Remove the wire holder (right side).

6

Loosen and remove the triangle link and remove the original shock absorber downward.

7

Remove the upper bracket from the original shock and mount it on the Öhlins shock absorber.

👁 Note!

Before installing the Öhlins shock absorber clean the vehicle thoroughly.

8

Use the provided tie wraps to position the preload adjuster hose to the reservoir hose.

👁 Caution!

Ensure that the hydraulic preload adjuster hose runs in soft bends. Also check that it does not come in contact with the exhaust pipe or any sharp edges.

9

Install the Öhlins shock absorber from below. Start with the preload adjuster and reservoir and guide these through the swing arm.

10

Lift the tank and install the upper shock attachment.

11

Install the triangle link.

👁 Note!

Lower the motorcycle so that the shock absorber is slightly compressed, before tightening the screws.

12

Install the bracket (03102-05) on the reservoir parallel to the reservoir end.

13

Install the bracket and the reservoir on the bracket-plate (21617-06). Use the screws (2x 05404-01) provided in this kit.

14

Install the bracket plate together with the wire holder in between the passenger footpegs. Use the same screws from the original preload adjuster and wire holder.

15

Install the hydraulic preload adjuster on the plate with the provided screws (2x 05404-07) and washers (4x 00153-04).

16

Reinstall tank, covers and seat.

17

Make sure that all removed parts are reinstalled in the same way as they were before the installation of the Öhlins shock absorber.

👁 Note!

It is not possible to fit the hugger/mud guard accessory when you have installed the Öhlins shock absorber.

👁 Caution!

Make sure that all screws are tightened to the correct torque and that nothing fouls or restricts movement of the shock absorber when the suspension is fully compressed or extended.

