

Adjustments

⚠ Warning!

Before riding, always make sure that the basic settings made by Öhlins are according to recommended Set-up Data. Read about adjustments and setting up in the Öhlins Owner's Manual before you make any adjustments. Contact an Öhlins dealer if you have any questions about setting up the shock absorber.

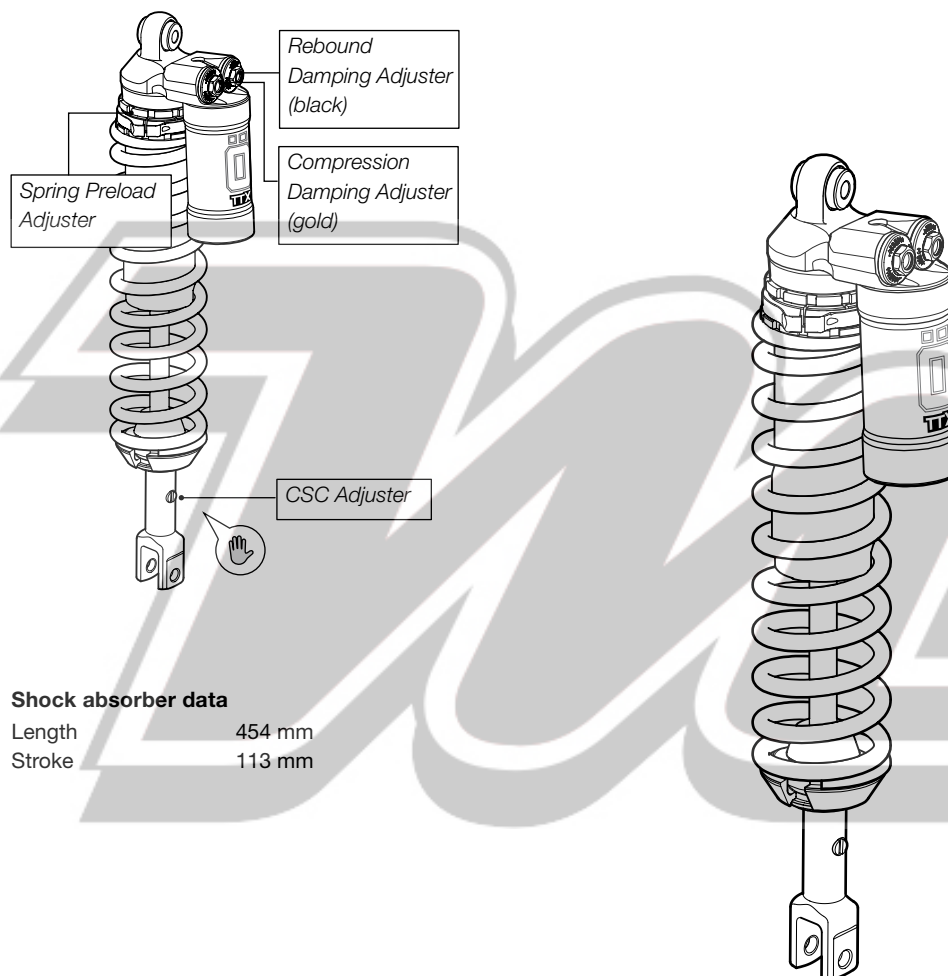

Set-up Data

Recommended set-up

Spring preload	5 turns (10 mm)
Rebound damping	12 clicks
Compression damping	12 clicks
CSC damping	18 clicks

Free sag and Ride height

R1 - R2	33 ± 3 mm
R1 - R3	103 ⁺³ / ₋₂

Shock absorber data

Length	454 mm
Stroke	113 mm

Before installing this product, check the contents of the kit. If anything is missing, please contact your nearest Öhlins dealer.

👁 Note!

Please note that the product image in this folder may differ from the product you have purchased.

Kit Contents

	Part No.	Pcs.
Shock absorber	HA 1084	1
Spring clip	00629-06	1
C-spanner single	00710-02	1
Öhlins Sticker	00197-01	2
Memo Notes Sticker	01180-01	1
Owner's Manual	07253-01	1
General Info Sheet	01198-01	1

👁 Note!

No spring included in this kit. See the Spring Guide in this folder, or contact an Öhlins dealer for advise.

Please note that during storage and transportation, especially at high ambient temperature, some of the oil and grease used for assembling may leak and stain the packaging. This is in no way detrimental to the product, wipe off the excessive oil/grease with a cloth.

⚠ Warning!

Before installing this product, read the Öhlins Owner's Manual. The shock absorber is an important part of your vehicle and may affect the stability of your vehicle.

👁 Öhlins products are subject to continuous improvement and development, therefore, although these instructions include the most up-to-date information available at the time of printing, minor updates may occur.

To find the latest information contact your Öhlins distributor. Please consult your Öhlins dealer if you have any questions regarding the contents in this document.

Part no. HA1084
Issued 2010-04-22



© Öhlins Racing AB. All rights reserved. Any reprinting or unauthorized use without the written permission of Öhlins Racing AB is prohibited.

Öhlins Racing AB
Box 722
S-194 27 Upplands Väsby, Sweden
Phone +46 8 590 025 00
fax +46 8 590 025 80



www.ohlins.com

Shock Absorber for Husqvarna TE 450 **HA 1084**

Mounting Instructions



Brand	Rider's weight*	Spring	Spring Rate
Husqvarna TE450	70/154	06310-12	56
	75/165	06310-13	58
	80/176	06310-14	60
	85/187	06310-15	62
	90/198	06310-16	64
	95/209	06310-17	66

* Rider's weight: Rider wearing all riding equipment

Install the Spring

Note!

Install the spring to the shock absorber before installing the shock absorber on the vehicle.

- 1 Measure the free length of the spring (A).
 - 2 Loosen the screw on the spring platform clamp so that you can move the spring platform as far up as needed to install the spring.
 - 3 Put the shock absorber up-side-down in a vice so that you can install the spring and the spring clip.
- Note!**
The spring platform and spring are press fitted. Push hard to install the spring.
- 4 Measure the spring length. Adjust the spring preload to the recommended setting, see section **Adjustments** and **Set-up data** in this folder.

- 5 Install the shock absorber to the vehicle according to the procedure in this folder. Check sag and ride height (see the Owner's Manual) and adjust the spring preload again if necessary.

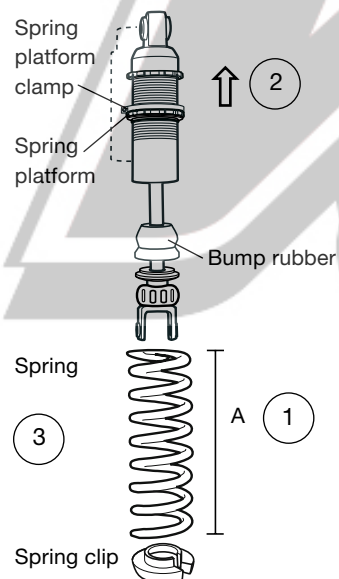

Note!

Tighten the screw on the spring platform clamp before riding the motorcycle.

Warning!

It is advisable to have an Öhlins dealer install the shock absorber.

When installing, consult your Vehicle Service Manual.

- 1 Put the motorcycle on a workstand so that the rear wheel barely touches the ground.

Warning!

Make sure the vehicle is securely supported so that it will not tip.

- 2 Remove the seat.
- 3 Remove the right side number plate.
- 4 Loosen the silencer from the subframe. Leave it attached to the exhaust pipe.
- 5 Loosen the subframe from the frame. Remove the hose clamp holding the airbox to the carburetor. Remove the whole unit with rear fender, subframe and air box.
- 6 Loosen the lower and the upper attachment of the original shock absorber and remove it.

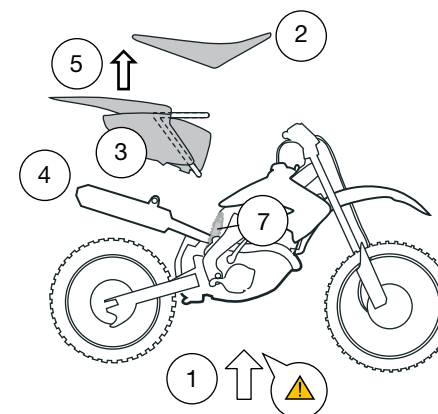

Note!

Before installing the Öhlins shock absorber clean the vehicle thoroughly.

- 7 Install the Öhlins shock absorber in the same way as the original unit. Do not tighten yet.

Note!

Lower the motorcycle so that the shock absorber is slightly compressed, before tightening the screws.

- 8 Tighten the attachment screws.

- 9 Put the air box, subframe, rear fender, number plate and seat back in position and fasten them. Make sure that all removed parts are installed in the same way as they were before the installation.

Caution!

Make sure that all screws are tightened to the correct torque and that nothing fouls or restricts movement of the shock absorber when the suspension is fully compressed or extended.