

Adjustments

⚠ Warning!

Before riding, always make sure that the basic settings made by Öhlins are according to recommended Set-up Data. Read about adjustments and setting up in the Öhlins Owner's Manual before you make any adjustments. Contact an Öhlins dealer if you have any questions about setting up the shock absorber.

Compression and Rebound Adjuster

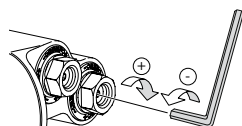

Use a 3mm Allen key to adjust.

Set-up Data

Recommended Set-up

Spring preload	21 mm
Rebound damping	14 clicks
Compr. damping	12 clicks

Shock Absorber Data

Shock absorber length	294,5 mm
Stroke	60 mm

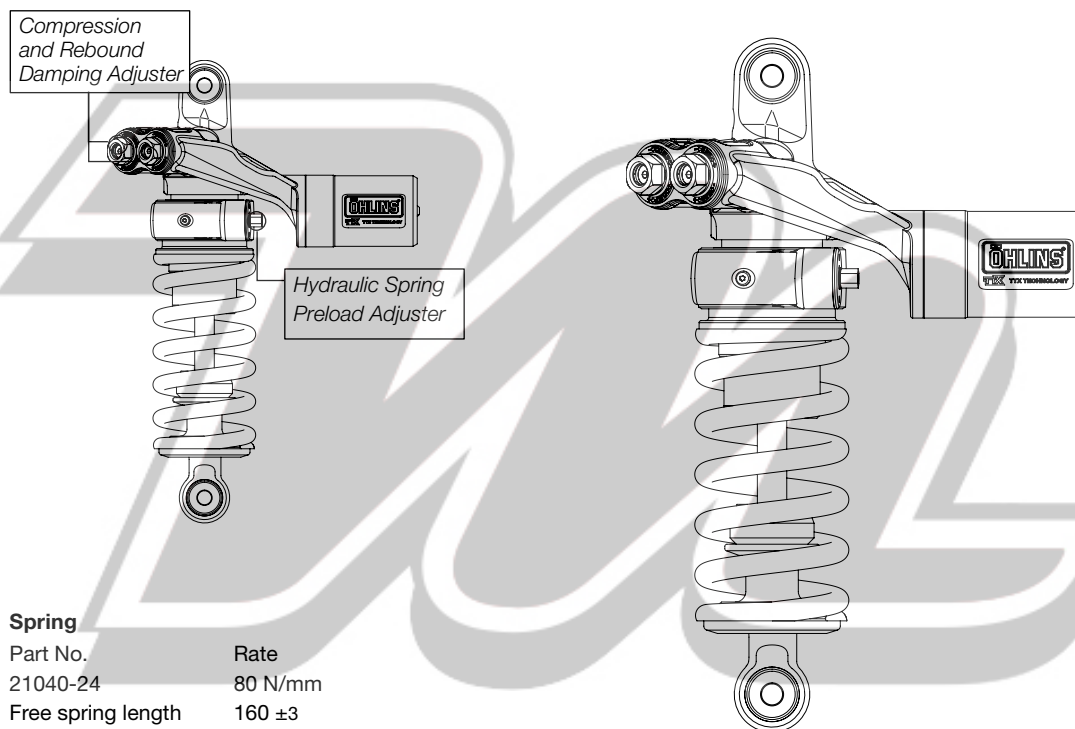

Spring

Part No.	Rate
21040-24	80 N/mm
Free spring length	160 ±3

Before installing this product, check the contents of the kit. If anything is missing, please contact an Öhlins dealer.

Kit Contents

	Part No.	Pcs.
Shock absorber	DJ931	1
Öhlins Sticker	00192-01	2
Memo Notes Sticker	01180-01	1
Owner's Manual	07242-01	1

Please note that during storage and transportation, especially at high ambient temperature, some of the oil and grease used for assembling may leak and stain the packaging. This is in no way detrimental to the product, wipe off the excessive oil/grease with a cloth.

⚠ Warning!

Before installing this product, read the Öhlins Owner's Manual. The shock absorber is an important part of your vehicle and may affect the stability of your vehicle.

Öhlins products are subject to continuous improvement and development, therefore, although these instructions include the most up-to-date information available at the time of printing, minor updates may occur.

To find the latest information contact your Öhlins distributor. Please consult your Öhlins dealer if you have any questions regarding the contents in this document.

Part no. DU_931_0
Issued 2011-11-21



Shock Absorber for Ducati 1098 **DU 931**

Mounting Instructions

© Öhlins Racing AB. All rights reserved. Any reprinting or unauthorized use without the written permission of Öhlins Racing AB is prohibited.

Öhlins Racing AB
Box 722
S-194 27 Upplands Väsby, Sweden
Phone +46 8 590 025 00
fax +46 8 590 025 80



www.ohlins.com



How to install

⚠ Warning!

It is advisable to have an Öhlins dealer install the shock absorber.

When installing, consult your Vehicle Service Manual.

1
Put the motorcycle on a workstand so that the rear wheel barely touches the ground.

⚠ Warning!

Make sure the vehicle is securely supported so that it will not tip.

2
Loosen the left footpeg and leave it for now.

3
Remove the rubber plug and loosen the lower mount for the original shock absorber.

4
Reinstall the left footpeg-bracket.

5
Loosen the screw at the back of the lower side covers (left and right).

6
Remove the right footpeg-bracket.

7
Remove the black cover for the exhaust pipe (right side).

8
Disconnect the expug-cables.

9
Remove the silencers, and the mid exhaust pipes.

10
Remove the bolts for the rocker arm. Begin with bolt **A**. Then lower the rear wheel/swing arm to remove bolt **B**. Finally remove bolt **C** and remove the whole rocker arm.

11
Lower the swing arm or raise the motorcycle to remove the original shock absorber.

👁 Note!

Before installing the Öhlins shock absorber clean the vehicle thoroughly.

How to install

👁 Note!

Lower the motorcycle so that the shock absorber is slightly compressed, before tightening the screws.

12
Install the ÖHLINS shock absorber and all parts in reverse order.

13
Make sure that all removed parts are reinstalled in the same way as they were before the installation of the Öhlins shock absorber.

👉 Caution!

Make sure that all screws are tightened to the correct torque and that nothing fouls or restricts movement of the shock absorber when the suspension is fully compressed or extended.

