

ADJUSTMENTS

Always ensure that the basic settings made by Öhlins are intact.

1 Spring preload

Use the C-spanner provided in this kit. Turn the spring platform nut (A) clockwise to increase the spring preload, turn counter clockwise to decrease it. Lock the setting with the lock nut (B).

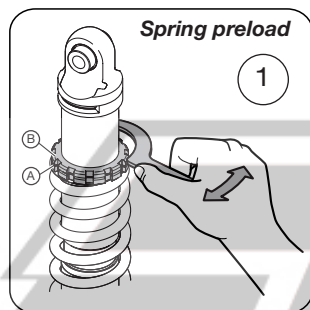

2 Rebound

Turn the screw above the end eye/bracket. Turn clockwise to increase damping, turn counter clockwise to decrease damping.

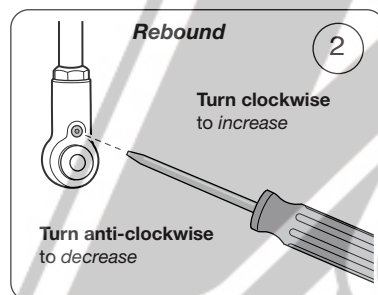

NOTE!

When delivered the Öhlins shock absorber is dialed to the recommended settings for the specific vehicle model. If you have changed the setting, reset according to the following: Turn the adjusters clockwise to fully closed (pos. 0). Then open the adjusters to their recommended click positions.

CAUTION!

Do not use force, delicate sealing surfaces can be damaged. Tighten only by hand.

3 Compression

Turn the slotted centre screw for **low speed**. Turn the hexagon screw for **high speed**. Turn clockwise to increase damping, turn counter clockwise to decrease damping.

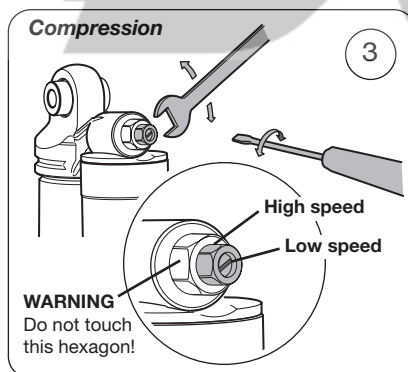

Mounting Instruction

WITH SET-UP DATA

SHOCK ABSORBER DU515 for Ducati 1098

Before installing this shock absorber, check the contents of the kit listed below. If anything is missing, please contact your nearest Öhlins dealer.

Kit Contents:

	Part no.	Pcs.
Shock absorber	DU515	1
C-spanner	00710-02	2
Öhlins Sticker	00192-01	2
Memo Notes Sticker	01180-01	1
Owner's Manual	07241-02	1

During storage and transportation, especially at high ambient temperature, some of the oil and grease used for assembling may leak and stain the packaging. This is in no way detrimental to the product, wipe off the excessive oil/grease with a cloth.

Set-up data

Spring preload	19 mm	Shock absorber length	294,5 mm
Rebound damping	14 clicks	Stroke	59,5 mm
Compr. damping HI	30 clicks	Spring	01091-24 (80N/mm)
Compr. damping LO	15 clicks	Free spring length	160 ±3

Before installing this product, read the Öhlins Owner's Manual!



HOW TO INSTALL

⚠ WARNING!

It is advisable to have an Öhlins dealer install the shock absorber.

1

Put the motorcycle on a workstand so that the rear wheel barely touches the ground.

⚠ WARNING!

Make sure the vehicle is securely supported so that it will not tip.

2

Loosen left footpeg and let it hang loose.

3

Remove the rubber plug and loosen the lower mount for the original shock absorber.

4

Reinstall the left footpeg-bracket.

5

Loosen the screw at the back of the lower side covers (left and right).

6

Remove the right footpeg-bracket.

7

Remove the black cover for the exhaust pipe (right side).

8

Disconnect the exp-up-cables.

9

Remove the silencers, and the mid exhaust pipes.

10

Remove the bolts for the rocker arm. Begin with bolt **A**. Then lower the rear wheel/swing arm to remove bolt **B**. Finally remove bolt **C** and remove the whole rocker arm.

11

Lower the swing arm or raise the motorcycle to remove the original shock absorber.

12

Install the ÖHLINS shock absorber and all parts in reverse order.

NOTE!

Lower the motorcycle so that the shock absorber is slightly compressed, before tightening the screw on the lower attachment.

NOTE!

Make sure that all screws are tightened to the correct torque and that nothing fouls or restricts movement of the shock absorber when the suspension is fully compressed or extended.

