

Adjustments

⚠ Warning!

Before riding, always make sure that the basic settings made by Öhlins are according to recommended Set-up Data. Read about adjustments and setting up in the Öhlins Owner's Manual before you make any adjustments. Contact an Öhlins dealer if you have any questions about setting up the shock absorber.

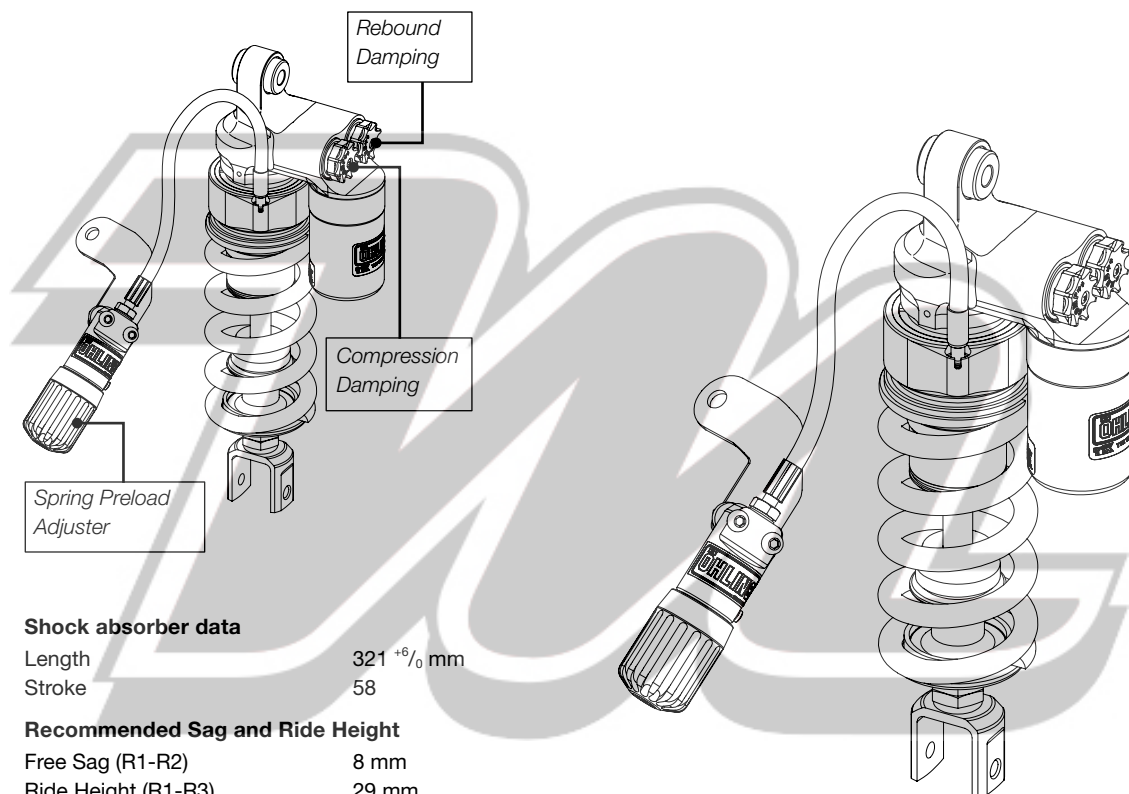

Before installing this product, check the contents of the kit. If anything is missing, please contact an Öhlins dealer.

Kit Contents

	Part No.	Pcs.
Shock absorber	BU 888	1
Washer 10/24/3	03118-05	1
Öhlins sticker	00192-01	2
Memo notes sticker	01180-01	1
Owner's manual	07242-01	1

Please note that during storage and transportation, especially at high ambient temperature, some of the oil and grease used for assembling may leak and stain the packaging. This is in no way detrimental to the product, wipe off the excessive oil/grease with a cloth.

⚠ Warning!

Before installing this product, read the Öhlins Owner's Manual. The shock absorber is an important part of your vehicle and will affect the stability.

Set-up Data

Recommended set-up

Rebound	12 clicks
Compression	12 clicks
Spring Preload	14 mm
Spring Rate	110 N/mm
Spring; Free length	160 mm

Shock absorber data

Length	321 ⁺⁶ / ₀ mm
Stroke	58

Recommended Sag and Ride Height

Free Sag (R1-R2)	8 mm
Ride Height (R1-R3)	29 mm

👁 Read about Free Sag and Ride height in the Öhlins Owner's Manual.

👁 Öhlins products are subject to continuous improvement and development, therefore, although these instructions include the most up-to-date information available at the time of printing, minor updates may occur.

To find the latest information contact your Öhlins distributor. Please consult your Öhlins dealer if you have any questions regarding the contents in this document.

Part no. BU888_0
Issued 2009-06-04



© Öhlins Racing AB. All rights reserved. Any reprinting or unauthorized use without the written permission of Öhlins Racing AB is prohibited.

Öhlins Racing AB
Box 722
S-194 27 Upplands Väsby, Sweden
Phone +46 8 590 025 00
fax +46 8 590 025 80



www.ohlins.com

Shock Absorber for Buell 1125

BU 888

Mounting Instructions



⚠ Warning!

It is advisable to have an Öhlins dealer install the shock absorber.

When installing, read the Vehicle Service Manual.

1

Put the motorcycle on a workstand so that the rear wheel barely touches the ground.

⚠ Warning!

Make sure the vehicle is securely supported so that it will not tip.

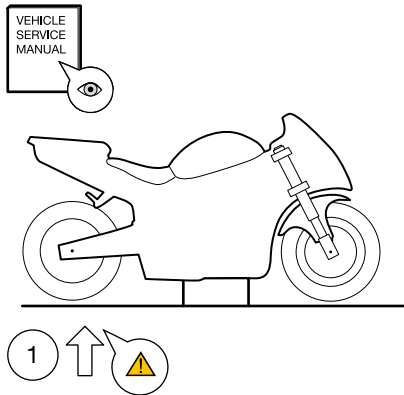

2

Remove the seat.

3

Loosen the cover on the rear frame.

4

Loosen the negative cable to the battery.

5

Loosen the brake fluid reservoir.

6

Loosen the shock absorber and the rear frame attachment screws.

7

Lift the rear frame up and to the left.

⚠ Caution!

Be careful with the brake fluid reservoir hose when lifting the rear frame. You may need to push the brake fluid reservoir down through the bottom of the rear frame.

8

Remove the original shock absorber from the right side.

👁 Note!

Clean the vehicle thoroughly before installing the Öhlins shock absorber.

9

Install the Öhlins shock absorber. Lead the hydraulic preload adjuster out to the right side, leave it there for now.

👁 Note!

Lower the motorcycle so that the shock absorber is slightly compressed, before tightening the screws.

10

Install the hydraulic preload adjuster on the rear foot rest bracket on the right side. Install it to the left(upper) attachment. Use the washer provided in this kit for the other attachment.

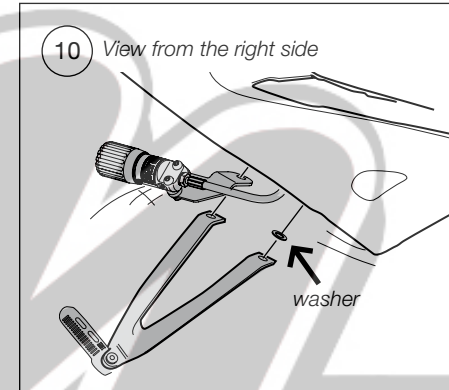

11

Make sure that all removed parts are reinstalled in the same way as they were before the installation of the Öhlins shock absorber.

⚠ Caution!

Make sure that all screws are tightened to the correct torque and that nothing fouls or restricts movement of the shock absorber when the suspension is fully compressed or extended.