

Adjustments

⚠ Warning!

Before riding, always make sure that the basic settings made by Öhlins are according to recommended Set-up Data. Read about adjustments and setting up in the Öhlins Owner's Manual before you make any adjustments. Contact an Öhlins dealer if you have any questions about setting up the shock absorber.

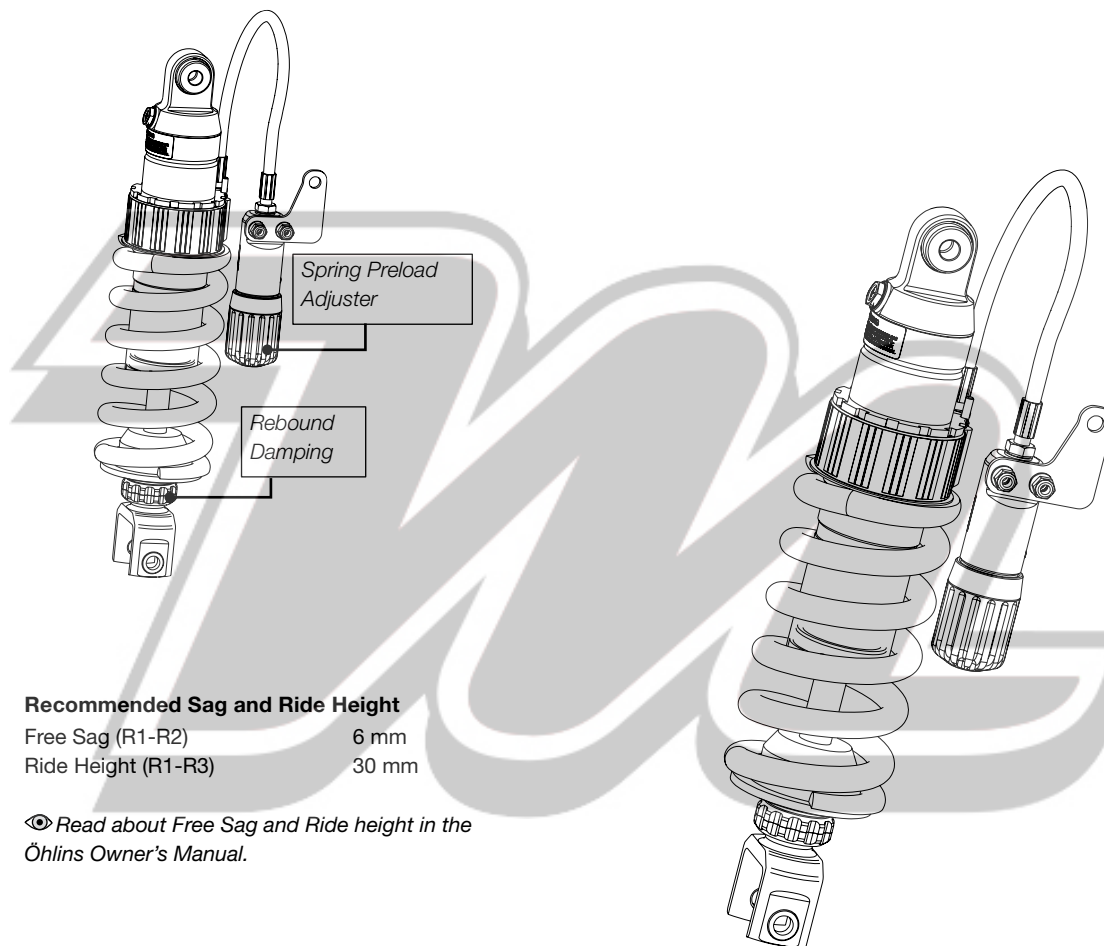

Before installing this product, check the contents of the kit. If anything is missing, please contact an Öhlins dealer.

Kit Contents	Part No.	Pcs.
Shock absorber	BM909	1
Washer BRB SMS70	00153-04	2
Sticker	00192-01	2
Nut M6	00430-02	2
Bracket	01082-03	1
Screw M6x30	05404-07	2
Tie rap	00231-01	2
Memo Notes Sticker	01180-01	1
Owner's Manual	07241-02	1

Please note that during storage and transportation, especially at high ambient temperature, some of the oil and grease used for assembling may leak and stain the packaging. This is in no way detrimental to the product, wipe off the excessive oil/grease with a cloth.

⚠ Warning!

Before installing this product, read the Öhlins Owner's Manual. The shock absorber is an important part of your vehicle and will affect the stability.

Set-up Data

Recommended set-up

Rebound	14 clicks
Spring Preload	10 mm
Spring Rate	210 N/mm
Spring; Free length	170 mm

Recommended Sag and Ride Height

Free Sag (R1-R2)	6 mm
Ride Height (R1-R3)	30 mm

👁 Read about Free Sag and Ride height in the Öhlins Owner's Manual.

Shock absorber data

Length	350 mm
Stroke	53

👁 Öhlins products are subject to continuous improvement and development, therefore, although these instructions include the most up-to-date information available at the time of printing, minor updates may occur.

To find the latest information contact your Öhlins distributor. Please consult your Öhlins dealer if you have any questions regarding the contents in this document.

Part no. BM909_0
Issued 2009-06-22



© Öhlins Racing AB. All rights reserved. Any reprinting or unauthorized use without the written permission of Öhlins Racing AB is prohibited.

Öhlins Racing AB
Box 722
S-194 27 Upplands Väsby, Sweden
Phone +46 8 590 025 00
fax +46 8 590 025 80



www.ohlins.com

Shock Absorber for BMW F800R

BM 909

Mounting Instructions



⚠ Warning!

It is advisable to have an Öhlins dealer install the shock absorber.

When installing, read the Vehicle Service Manual.

1

Put the motorcycle on a workstand so that the rear wheel barely touches the ground. The swing arm must be free, so that the suspension is unloaded.

⚠ Warning!

Make sure the vehicle is securely supported so that it will not tip.

2

Remove the seat.

3

Loosen the 4 screws (2 on the left and 2 on the right side) for the subframe and 1 screw for the silencer (on the subframe).

3

Loosen the screws for the original shock absorber.

4

Remove the original shock absorber; Gently lift the subframe and hold it while removing the original shock absorber. (Or loosen the fuel hose and the wire harness).

👁 Note!

Clean the vehicle thoroughly before installing the Öhlins shock absorber.

5

Install the ÖHLINS shock absorber; Remove the knob and pull the spring preload adjuster between the pipes out to the right side of the vehicle. Mount the upper and lower bolts (do not tighten yet) of the shock absorber - with the oil filling screw towards the rear.

6

Reinstall the subframe.

7

Pull out the spring preload adjuster on the left side of the vehicle and install the bracket on the adjuster.

8

Hang on the knob so it will fit on the adjustment screw (do not push hard) on the hydraulic spring preload adjuster. Fasten the knob, tighten the screw; tightening torque 3 Nm.

👁 Note!

Lower the motorcycle so that the shock absorber is slightly compressed, before tightening the screws.

9

Install the hydraulic spring preload adjuster with bracket. Use the original screw, but remove the washer.

10

Fasten the hose with tie raps.

⚠ Warning!

Make sure that the hydraulic preload adjuster hose runs in soft bends. Also check that it does not come in contact with the exhaust pipe or any sharp edges.

11

Lower the bike and tighten the screws of the upper and lower bolts of the Öhlins shock absorber.

👁 Caution!

Make sure that all screws are tightened to the correct torque and that nothing fouls or restricts movement of the shock absorber when the suspension is being fully compressed or extended.

12

Reinstall all removed parts in the same way as they were before installation of the Öhlins shock absorber.

