

## SET-UP DATA

Rebound adjustment	16 clicks
Low speed compression	20 clicks
High speed compression	1.5 turns
Spring preload	10 mm
Spring rate	80 N/mm

Free sag, rear 30 ± 5 mm

Shock absorber length	415.5 mm
Stroke	108.5 mm

### NOTE!

Read more about the shock absorber and its different settings in your Öhlins Owners Manual.

Before riding, always ensure that the basic settings made by Öhlins are intact.

## ADJUSTMENTS

### 1 Spring preload

Use the C-spanner provided in this kit. Turn the spring platform nut (1a) to set the spring preload. Lock the setting with the lock nut (1b).

### 2 Compression damping

Adjust on top of the reservoir. Low speed adjustment: Slotted centre screw. High speed adjustment: Hexagon screw.

### 3 Rebound damping

Adjust by turning the wheel on the piston shaft above the end eye.

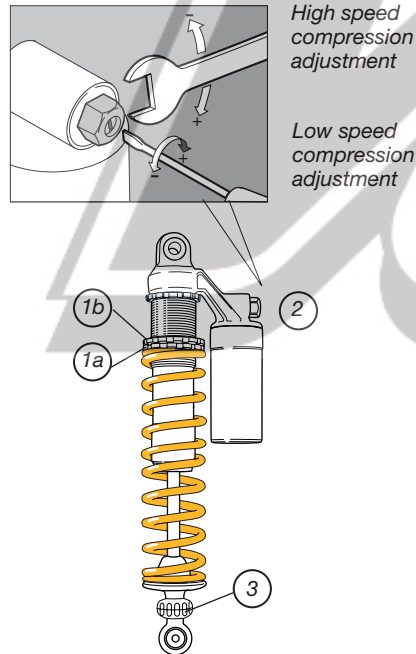

### CAUTION!

Do not use force, delicate sealing surfaces can be damaged.

BM688 - Issued 2006 04 25



Öhlins Racing AB, Box 722, S-194 27 Upplands Väsby, Sweden.  
Phone +46 8 590 025 00. Fax +46 8 590 025 80.

[www.ohlins.com](http://www.ohlins.com)



# Mounting Instructions

## Öhlins Shock Absorber BM688 for BMW HP2

### Kit Contents

Before installing this shock absorber, please check the contents of the kit listed below. If any part is missing, please contact your Öhlins dealer.

	Part no. (pcs.)
Shock absorber 46PRXQ	BM688 (1)
C-spanner	00710-02 (1)
Memo Notes Sticker	01180-01 (1)
Öhlins Sticker	00197-01 (2)
Öhlins Owners Manual	(1)

Öhlins Racing AB cannot be held responsible for any damage to the shock absorber, vehicle or injury to persons, if the instructions for fitting and maintenance are not followed exactly. Similarly, the warranty will become null and void if the instructions are not adhered to.

### In this manual

Safety precautions  
Mounting instructions  
Before riding  
Set-up data  
Adjustments

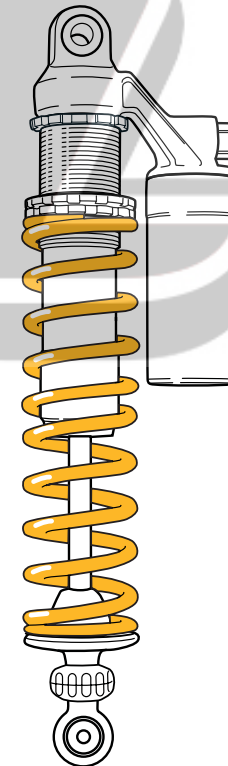

© Öhlins Racing AB. All rights reserved. Any reprinting or unauthorized use without the written permission of Öhlins Racing AB is prohibited. Printed in Sweden.

## SAFETY PRECAUTIONS

### Read this manual carefully!

Pay special attention to statements preceded by the following notations:



The Safety alert symbol means: Attention! Your safety is involved!

### WARNING

Failure to follow warning instructions may result in **severe or fatal injury** to anyone working with, inspecting or using this shock absorber, or to bystanders.

### CAUTION!

Caution indicates that special precautions must be taken to avoid damage to the shock absorber.

### NOTE!

Indicates information that is of importance regarding mounting procedures.

### NOTE!

Öhlins products are subject to continuous improvement and development. Therefore, although these instructions include the most up-to-date information available at the time of printing, there may be minor differences between your shock absorber and this manual. Please consult your Öhlins dealer if you have any questions regarding the contents of this manual.

### NOTE!

During storage and transportation, especially at high ambient temperature, the oil and grease used for assembling may run out inside the packing and damage the expanded polystyrene packing material. This is not unusual and is in no way detrimental to the shock absorber.

### WARNING!

1. **Installing a shock absorber, that is not approved by the vehicle manufacturer, may affect the vehicle's stability.** Öhlins Racing AB cannot be held responsible for any personal injury or damage that may occur after fitting the shock absorber.

2. The **vehicle service manual must be referred to** when installing this shock absorber.

3. Please study and make certain you fully understand the mounting instructions and the owner's manual before handling this shock absorber. If you have any questions regarding proper installation procedures, contact an Öhlins dealer.



## MOUNTING INSTRUCTIONS

### WARNING!

1. It is advisable to have an Öhlins dealer install the suspension component.
2. Follow the instructions in the vehicle service manual when changing the suspension component.
3. When working on a lifted vehicle make sure it is securely supported to prevent it from tipping.

1

**Consult your vehicle service manual for safe procedure when removing the original shock absorber.**

2

Install the Öhlins shock absorber in the same way as the original unit. Fasten it by using the original bolts.

Piggyback reservoir at the top, on the left side.

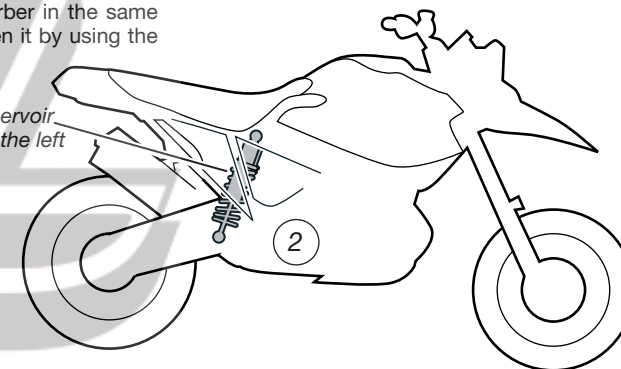

### NOTE!

If you have been working on a workstand when installing, put the motorcycle back on the floor before tightening the bolts. Make sure the vehicle is secure and will not fall over. You may need an assistant for this.

### NOTE!

Make sure that all bolts are tightened to the correct torque and that nothing fouls or restricts movement of the shock absorber when the suspension is being fully compressed or extended.

## BEFORE RIDING

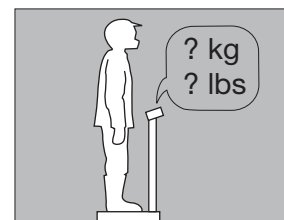
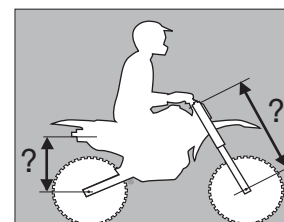

### IMPORTANT NOTICE!

Before riding your bike, check sag and ride height according to your Öhlins Owner's manual.

To get the most out of your suspension component it is of great importance to make proper settings and to use the correct spring for your weight - **full riding equipment on!**

We recommend you to read your Öhlins Owner's manual carefully to understand the different effects of the different settings.