

Kit Contents

Description	Part No	Pcs
BMW R1200GS rear EC	BM666	1
Screw M6x12	01046-36	6
Screw M6x8	05404-11	4
Rubber bushing	21865-01	2
Bracket	21864-02	2
Bracket	21864-03	2
Bracket	21864-04	2
BMW R1200GS T36 EC	BM667	1
C-spanner	00710-05	1
Electrical Tap Connector	21310-01	1
Sticker Mechatronic sys	00191-46	2
Tie rap	00231-01	20
Owner's manual TTX	07242-01	1
Wire harness	21770-01	1
End cap 25/69	21780-01	4
ECU BMW R1200GS	35000-01	1

👁 Note!

Please note that this image is a general representation of the product and may differ slightly from your product.

👁 Note!

Please note that during storage and transportation, especially at high ambient temperature, some of the oil and grease used for assembling may leak and stain the packaging. This is in no way detrimental to the product, wipe off the excessive oil/grease with a cloth.

👁 Note!

Before installing this product, check the contents of the kit. If anything is missing, please contact an Öhlins dealer.

⚠ Warning!

Before installing this product, read the Öhlins Owner's Manual. The shock absorber/front fork/steering damper is an important part of your vehicle and will affect the stability.

Shock absorber for BMW R1200GS

BM 670

Mounting Instructions

MOUNTING INSTRUCTIONS

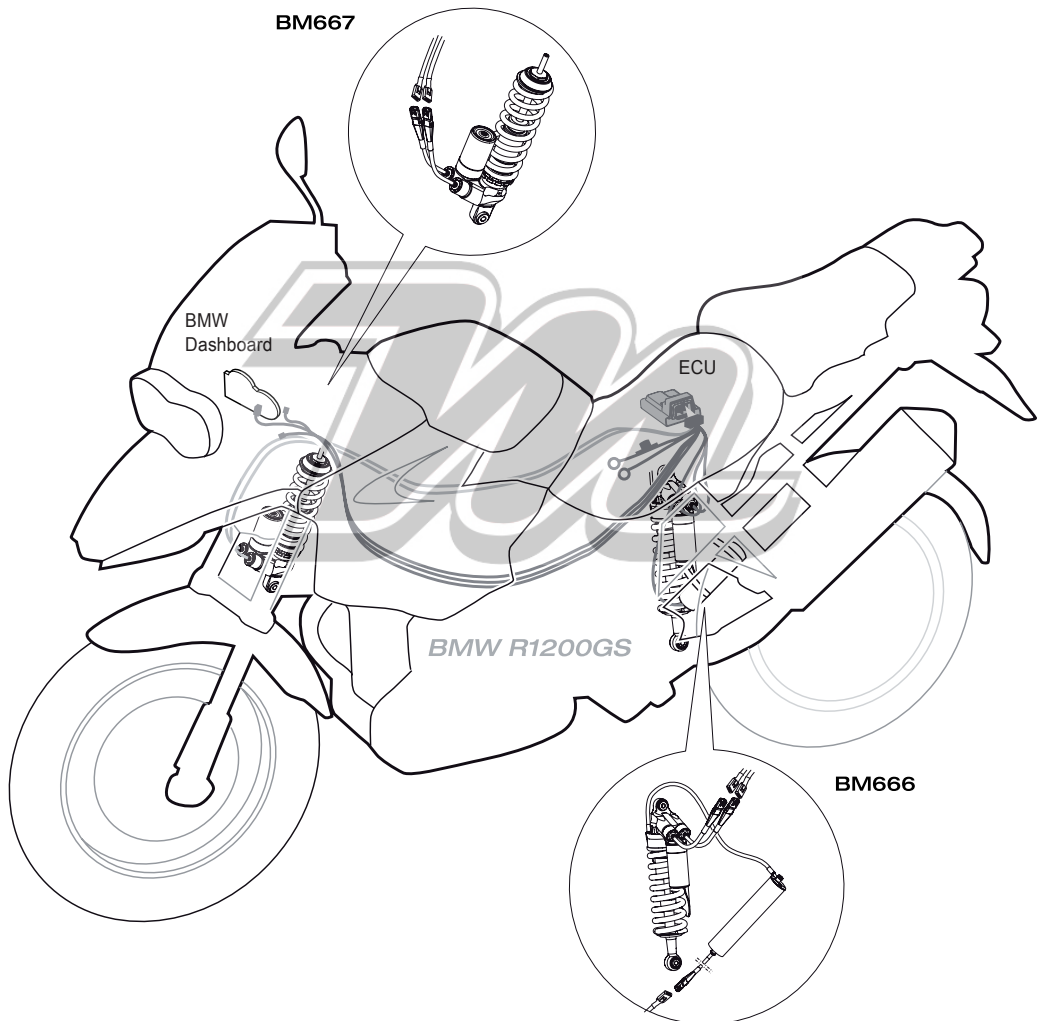

INSTALL THE FRONT SHOCK ABSORBER

Warning!

It is advisable to have an Öhlins dealer install the shock absorber/front fork/steering damper.

Warning!

If working on a raised vehicle, ensure it is securely supported so that it will not tip.

Note!

Before mounting this product clean the vehicle thoroughly.

Note!

When working on this product, always see the Vehicle Service Manual for vehicle specific procedures and important data.

→ **See figure on page 4.**

1

Put the motorcycle on a workstand so that the front wheel barely touches the ground.

2

Remove the seats.

3

Loosen the side fairings and lift them off the bike to reach the fuel tank.

Note!

The fairings have three quick mounts on each side. The mount towards the front can be loosened from the inside.

4

Remove the screws holding the front and tank fairings together.

5

Loosen the fuel tank (two screws on each side) and pull it towards the rear, so that the upper shock absorber attachment can be reached.

Note!

Model year 2008-2009 only;

Remove the five bolts that hold the ESA shock absorber system bracket. It may be necessary to loosen the main bolt to the lower suspension link so that the original shock absorber can be replaced.

6

Disconnect the two [2] electric connectors from the BMW ESA shock absorber system.

7

Remove the cable holder on the anti-twist stop (plastic part) at the upper shock mount. Release the twist stop from the frame by unfolding the top part, where the cable holder is installed.

8

Remove the plastic engine front cover (belt guard) to make the front shock removal and installation easier. If there is a standard or adventure crash bar installed, the center, lower left, and right hand parts need to be removed.

Note!

Lower the motorcycle so that the shock absorber is slightly compressed, before tightening the screws.

9

Install the Öhlins shock absorber. First install the upper attachment, then the lower. Use the original rubber mounts to the upper bracket.

10

Use the supplied Shrink hose covers to protect the bike's wire harness ESA connectors from water. Cut the covers so that they cover the connector and 20mm of the cord. Use a heat gun and heat the Shrink hose covers to 120° C to seal the connector.

11

Fasten the ESA connectors with tie-wraps.

12

Reinstall all the removed parts. (The seat does not need to be reinstalled yet if rear shock absorber is to be installed.)

Caution!

Make sure that all screws are tightened to the correct torque and that nothing fouls or restricts movement of the shock absorber when the suspension is fully compressed or extended.

→ **To install cables, go to page 7.**

INSTALL THE FRONT SHOCK ABSORBER

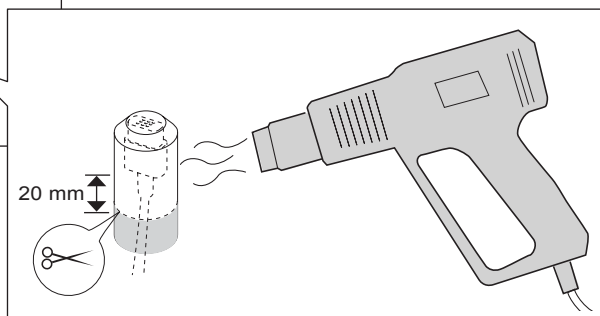
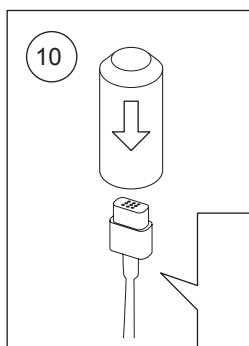
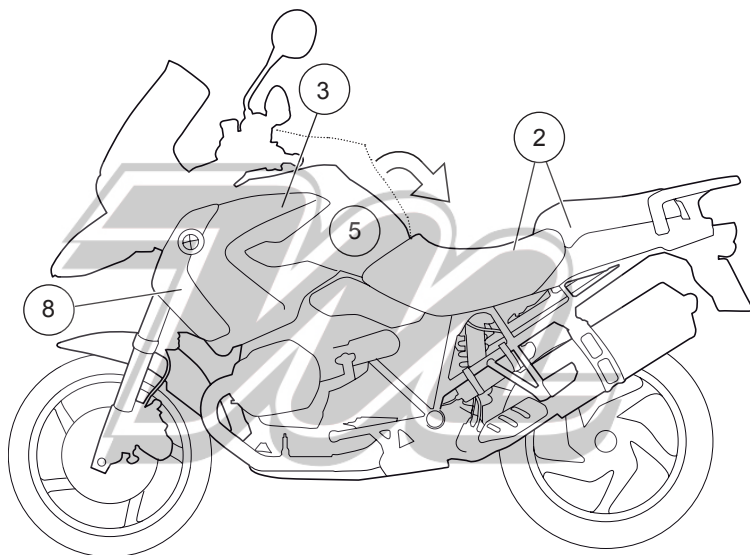

INSTALL THE REAR SHOCK ABSORBER

⚠ Warning!

It is advisable to have an Öhlins dealer install the shock absorber/front fork/steering damper.

⚠ Warning!

If working on a raised vehicle, ensure it is securely supported so that it will not tip.

👁 Note!

Before mounting this product clean the vehicle thoroughly.

👁 Note!

When working on this product, always see the Vehicle Service Manual for vehicle specific procedures and important data.

→ See figure on page 6

1

Put the motorcycle on a workstand so that the rear wheel barely touches the ground. The swing arm must be free so that the suspension is unloaded.

2

Unlock the seats and remove them.

3

Loosen and remove the silencer.

4

Disconnect the two [2] electric connectors from the BMW ESA shock absorber system.

5

Remove the lower shock absorber bolt.

6

Remove the upper shock absorber bolt.

7

Remove the original shock absorber from the left side of the motorcycle.

8

Install the Öhlins shock absorber in the same way as the original unit.

👁 Note!

Lower the motorcycle so that the shock absorber is slightly compressed, before tightening the screws.

9

Put the rubber (21865-01) on the bracket (21864-03), add Loctite 222 to the screw (05404-11) and tighten.

10

Put the bracket (21864-04) on the rubber and add Loctite 222 to the screw (05404-11) but do not tighten fully.

11

Install the bracket assembly to the preload adjuster using the M6 screws (01046-36). Note the orientation of the bracket assemblies. When the preload adjuster has enough clearance to the frame. Make sure that the preload adjuster also has clearance to the rear wheel movement.

12

Use the supplied tie raps to fixate the hydraulic preload adjuster hose.

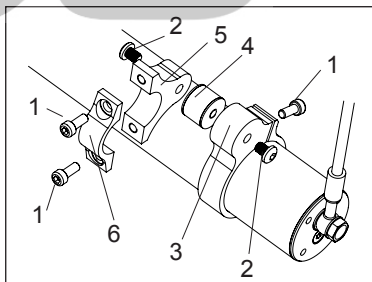

Part No.

- 1. 01046-36
- 2. 05404-11
- 3. 21864-04
- 4. 21865-01
- 5. 21864-03
- 6. 21864-02

13

Use the supplied Shrink hose covers to protect the bike's wire harness ESA connectors from water. Cut the covers so that they cover the connector and 20mm of the cord. Use a heat gun and heat the Shrink hose covers to 120° C to seal the connector.

👁 Caution!

Make sure that the hose runs in soft turns.

👁 Caution!

Make sure that all screws are tightened to the correct torque and that nothing fouls or restricts movement of the shock absorber when the suspension is fully compressed or extended.

→ To install cables, go to page 7

INSTALL THE REAR SHOCK ABSORBER

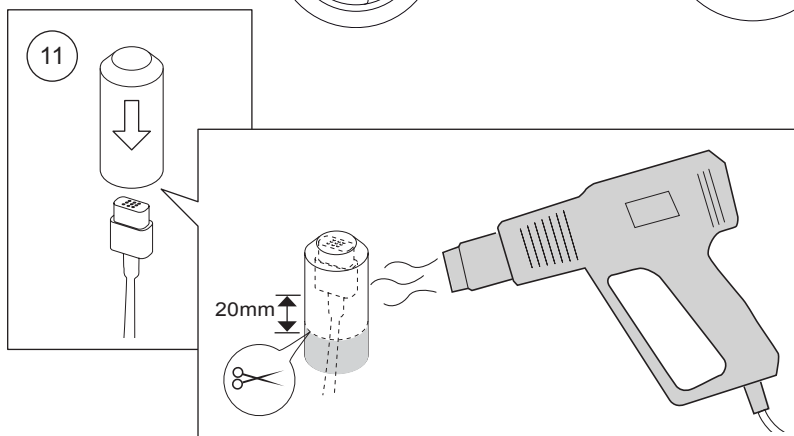
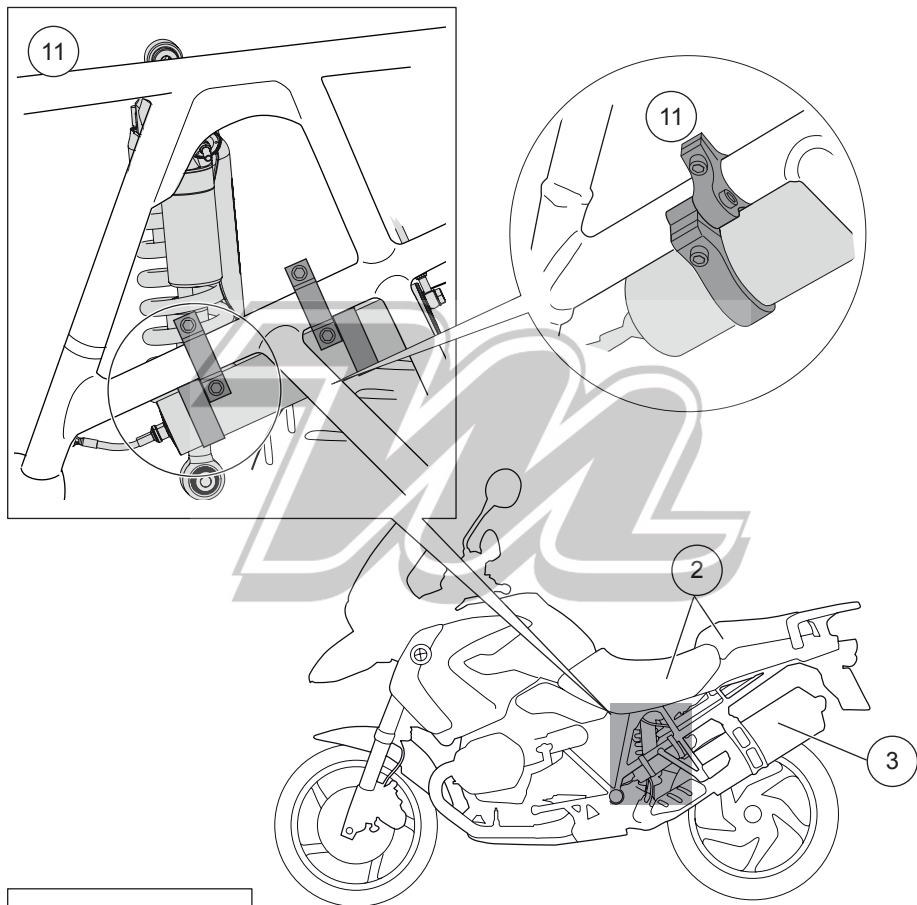

INSTALL THE WIRE HARNESS

1
Disconnect the original dashboard.

2
Place the Öhlins ECU in the tool box. Use double-coated adhesive tape.

→ See figure on page 9

3
See the table on page 9 for correct wire harness connections.

Caution!

If you have any questions regarding wire harness installation contact Öhlins. Incorrect connections may cause poor function or no function at all.

4
Fasten the Öhlins wire harness according to the figure on page 9.

5
Use tie raps every 100mm and fasten the wires to the BMW wire harness, on both sides.

6
Lead the system on/off wire to the front lights along the existing wire harness. Use the air vent to access the running light wires.

7
Remove the front light cover and locate the yellow wire to the lamp connector. Use the supplied wire tap to connect the system on/off wire to the yellow wire.

8
Reconnect the lamp connector and reinstall the front light cover.

9
Turn on the running light and the system will start.

Note!

You can only change suspension and preload settings when the running light is on.

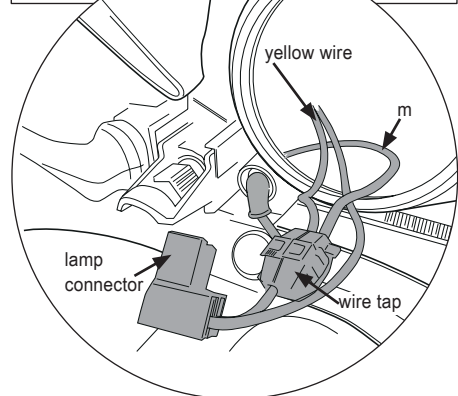
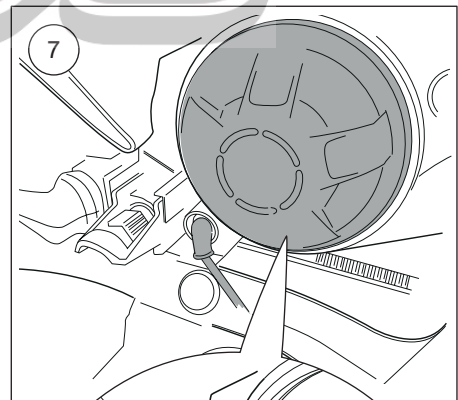
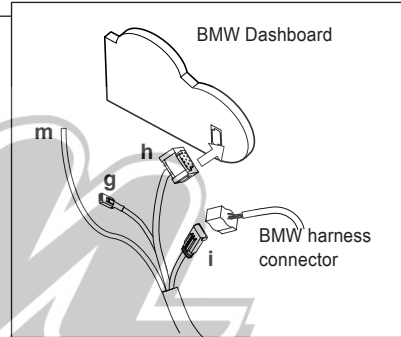
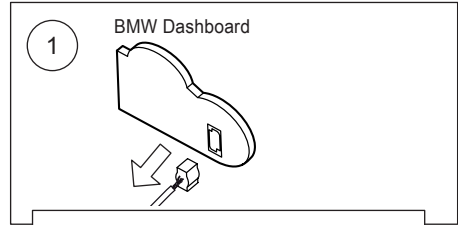

INSTALL THE WIRE HARNESS

Caution!

Ensure that no cables are in contact with sharp edges or hot areas.

10

Reinstall the fuel tank, side fairings and seats.

Caution!

Make sure that all screws are tightened to the correct torque and that nothing fouls or restricts movement of the shock absorber when the suspension is fully compressed or extended.

Calibrate the Preload Adjuster

1

Turn on the ignition and start the engine. The bike performs a self-check (see dashboard). It takes about 5 seconds.

2

Press the “ESA” button quickly once.

3

Press both the “ESA” and the “INFO” buttons at the same time for 2-3 seconds.

4

When the preload adjustment starts, release the buttons.

5

When the preload adjustment is ready (silent), turn off the ignition.

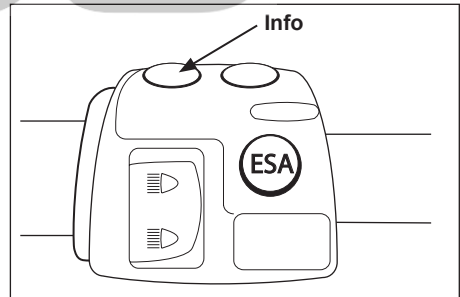

INSTALL THE WIRE HARNESS

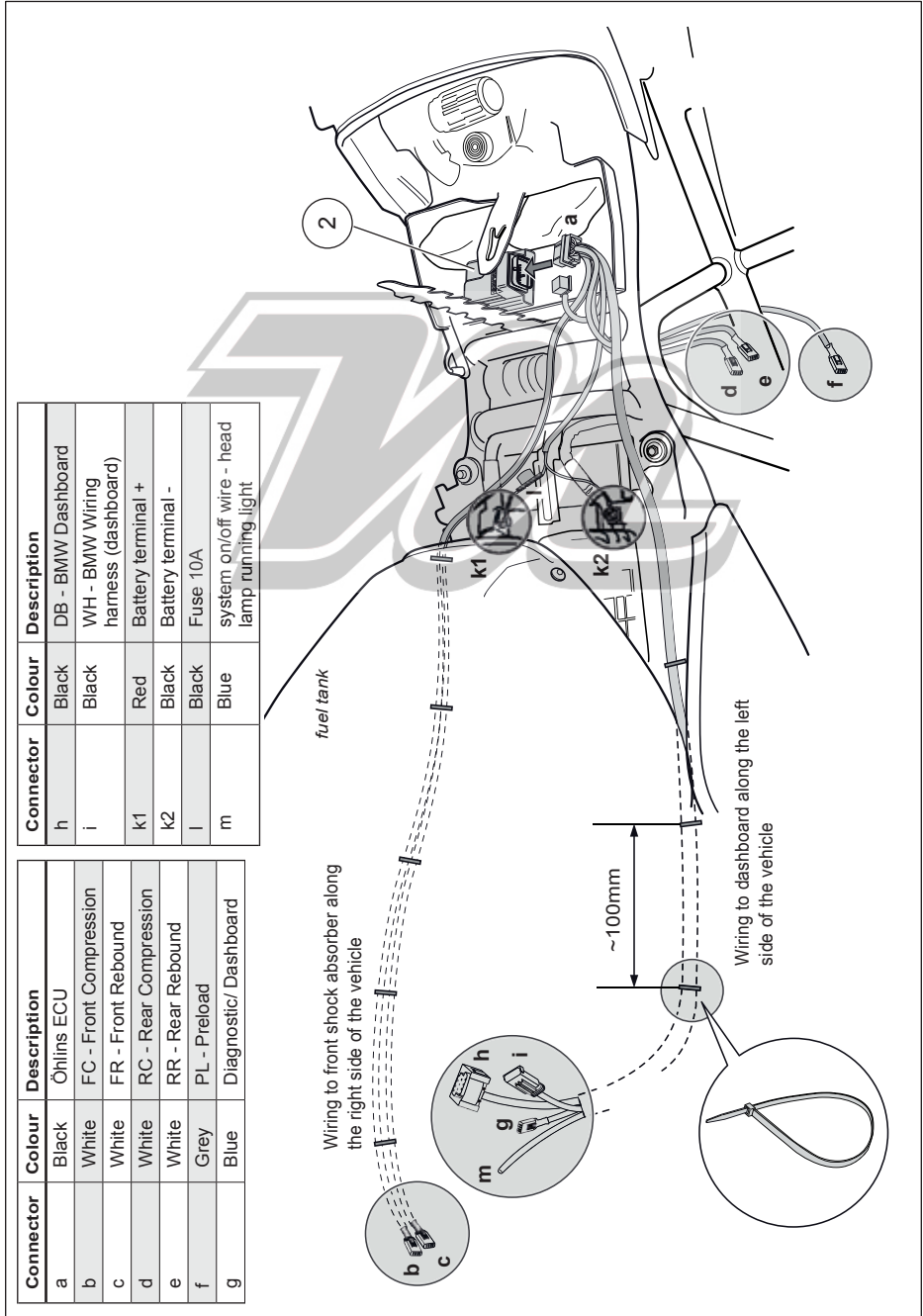

EC SUSPENSION SET UP MODES

Select the System driving modes for the Öhlins EC-suspension system in the same way as for the standard ESA-system.

The (driving) pre-load modes can be set when the engine is running on idle.

A **short push** on the ESA-button shows which setting is selected.

A **long push** will alter between the driving modes.

Stop pushing when you see the desired setting on the display.

Once you have chosen the driving mode you can choose the damping modes by short pushes on the ESA button as described below.

The damping setting road-modes:

COMF, NORM and SPORT

Off-road settings:

SOFT, NORM and HARD

The settings can be selected any time when the ignition is on. A quick push on the ESA-button shows the selected setting. Repeat the short pushing until the desired damping setting shows and release the button. Each short push will alter to the next of the 3 available damping settings for the selected driving mode.

There are 3 different driving modes available for normal roads and different load conditions:

For these driving modes there are three different damping settings:

COMF: (Used for various daily riding)

This setting is an intelligent mode that chang-



one-up



one-up with luggage



two-up (with luggage)

es the suspension setting depending on the riding speed. The damping levels are increased with the speed. When the speed is reduced the damping modes will automatically switch back through the softer settings. This intelligent mode is a feature not existing in the standard ESA-system and is governed by the Öhlins-ECU.

NORM: Is a fixed setting mode used for various riding.

SPORT: Used for riding on your favorite winding roads or fast transportation. This setting is also suitable for very high load.

EC SUSPENSION SET UP MODES

Gravel road and off-road modes



Predominantly smooth terrain

For Gravel roads or bad asphalt roads

SOFT: Used for slow riding on normal smooth gravel roads with occasional pot holes. One rider with light luggage.

NORM: Used for normal load conditions on average type gravel roads.

HARD: For fast riding and or high load under rough road conditions.

For Rough gravel roads and terrain riding and



Uneven terrain

for high load.*

SOFT: Used for slow riding under rough conditions

NORM: Used for average riding under rough conditions and normal load.

HARD: This mode is for tough riding under bad conditions or off-road, also suitable for high load.

**If you need maximum ground clearance riding under rough conditions we recommend adding 5-10 mm extra pre-load on the front shock absorber manually. Adjust back to a normal position for normal riding.*

SETUP DATA

Recommended Set-up

The adjuster positions are set automatically by the Öhlins ECU.

Recommended sag front and rear.

See the TTX Owner's Manual for further instructions how to measure sag.

Front spring rate	50 N/mm
Free length	220 mm
Spring preload	10 mm
F1-F2 =	42 mm
F1-F3 =	51 mm

Rear spring rate	130 N/mm
Free length	240 mm
Spring preload	17 mm
(Adjustment range 0 to +10 mm)	
R1-R2 =	20 mm
R1-R3 =	55 mm

👁️ Öhlins products are subject to continuous improvement and development, therefore, although these instructions include the most up-to-date information available at the time of printing, minor updates may occur.

To find the latest information contact an Öhlins distributor. Please contact Öhlins if you have any questions regarding the contents in this document.

Part no. MI_BM670_2
Issued 2013-07-05



© Öhlins Racing AB. All rights reserved. Any reprinting or unauthorized use without the written permission of Öhlins Racing AB is prohibited.

Öhlins Racing AB
Box 722
S-194 27 Upplands Väsby, Sweden
Phone +46 8 590 025 00
fax +46 8 590 025 80



www.ohlins.com