

ADJUSTMENTS

Always ensure that the basic settings made by Öhlins are intact.

1 Spring preload

Use the C-spanner provided in this kit. Turn the spring platform nut (A) to set the spring preload. Lock the setting with the lock nut (B).

2 Rebound compression adjuster

Turn the wheel on the piston shaft above the end eye/ bracket. Turn clockwise to increase damping, turn counter clockwise to decrease.

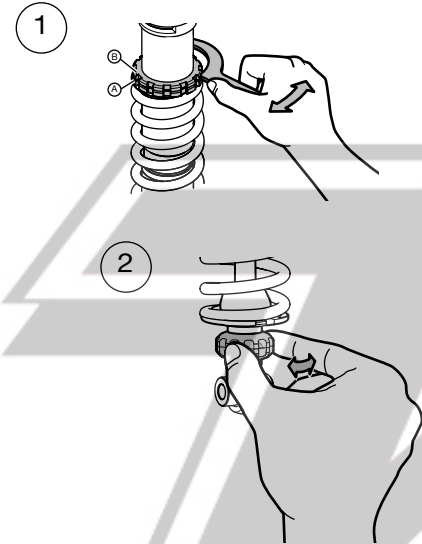

SET-UP DATA

Data:

Total length 347 mm
Stroke 95

Recommendations:

Spring preload 17 mm
Rebound damping 14 clicks

Recommended Sag and Ride Height

F1 - F2: 25 - 35 mm
F1 - F3: 35 - 45 mm
R1 - R2: 30 - 40 mm
R1 - R3: 65 - 75 mm

👁️ Read more about sag and ride height in the Öhlins Owner's Manual.

Mounting Instructions

WITH SET-UP DATA

SHOCK ABSORBER BM607 for BMW R1200 GS Adventure

Before installing this shock absorber, check the contents of the kit listed below. If anything is missing, please contact your nearest Öhlins dealer.

Kit Contents:

	Part no.	Pcs.
Shock absorber	BM 607	1
C-spanner	00710-02	1
Öhlins Sticker	00192-01	2
Memo Notes	01180-01	1
Owner's Manual		1

During storage and transportation, especially at high ambient temperature, the oil and grease used for assembling may leak inside the packing and damage the expanded polystyrene packing material. This is not unusual and is in no way detrimental to the shock absorber.



Before installing this product, read the Öhlins Owner's Manual!

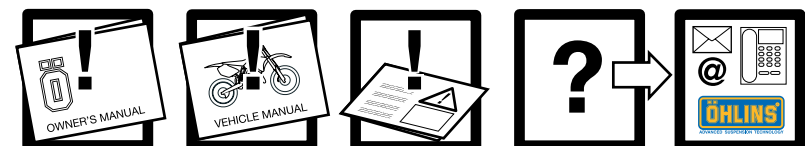

Öhlins Racing AB, Box 722, S-194 27 Upplands Väsby, Sweden.
Phone +46 8 590 025 00 Fax +46 8 590 025 80
www.ohlins.com

HOW TO INSTALL

⚠ WARNING!

It is advisable to have an Öhlins dealer install your Öhlins shock absorber. Especially if the motorcycle has ESA- shock absorber system.

1

Remove the driver's and the passengers's seats.

2

Remove the gas tank cover.

3

Loosen the brake line bracket.

4

Put the motorcycle on a workstand so that the front wheel barely touches the ground.

⚠ WARNING!

Make sure the vehicle is securely supported so that it will not tip.

5

Remove the crash frame.

NOTE!

If the motorcycle has the ESA shock absorber system; Remove the five bolts that hold the ESA shock absorber system bracket. It may be necessary to loosen the main bolt to the lower suspension link so that the original shock absorber can be replaced. Disconnect the electrical connectors from the ESA shock absorber system and make sure they are safe from contact with water.

6

Remove the lower attachment of the original shock absorber.

7

Remove the upper attachment (from above).
Remove the original shock absorber downwards.

NOTE!

Recommendation! Before installing the Öhlins shock absorber; clean the vehicle thoroughly.

8

Install the Öhlins shock absorber. Use the original rubber and sleeve for the upper attachment. Fasten the lower attachment. Do not tighten yet.

NOTE!

Lower the motorcycle so that the shock absorber is compressed 1 mm, before tightening the screws.

9

Tighten the upper and the lower attachments.

10

Reattach the brake line bracket, crash frame, the gas tank cover and the seats. Make sure that all removed parts are installed in the same way as they were before the installation.

NOTE!

Make sure that all screws are tightened to the correct torque and that nothing fouls or restricts movement of the shock absorber when the suspension is being fully compressed or extended.

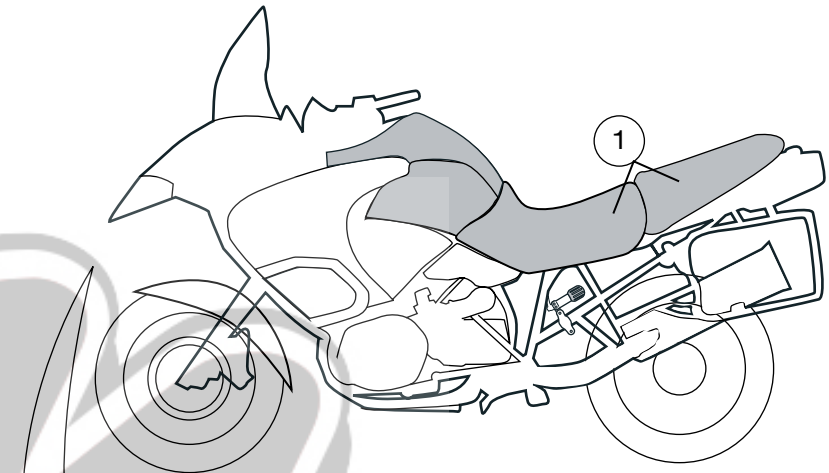

Front view

