

Kit contents		
Description	Part No	Pcs
Shock absorber	BM511	1
Washer Ø8	00153-01	2
Tie-rod	00231-01	2
Nut M8	00430-05	1
Screw M8x50	01046-25	1
Sticker "Memo notes"	01180-01	1
Sticker "ÖHLINS" wh/tr	01185-01	2
Sticker "ÖHLINS" bl/tr	01185-04	2
Owner's manual	07241-02	1

**Note!**

*This product can be used on a vehicle equipped with Dynamic ESA. However, the Dynamic ESA front fork will not function correctly when the Dynamic ESA shock absorber is disconnected. Therefore, it is recommended to also install an Öhlins cartridge kit. An error code and a warning light will appear in any circumstance. Contact an Öhlins dealer for advice*

**Note!**

*Please note that there can be small differences between your product and the images in these instructions.*

**Note!**

*Please note that during storage and transport, especially at high ambient temperature, some of the oil and grease used for assembly may leak and stain the packaging. This will not cause damage to the product, wipe off the excessive oil or grease with a cloth.*

**Note!**

*Before you install this product, check the kit contents. If anything is missing, please contact an Öhlins dealer.*

**Warning!**

*Before you install this product, read the Öhlins Owner's manual. This product is an important part of the vehicle and the vehicle stability.*

## Shock absorber for BMW R1200R & R1200RS

# BM 511

## Mounting Instructions

# MOUNTING INSTRUCTIONS

## **⚠ Warning!**

*We strongly recommend to let an Öhlins dealer install this product.*

## **⚠ Warning!**

*If you work with a lifted vehicle, make sure that it is safely supported to prevent it from tipping over.*

## **👁 Note!**

*When you work with this product, see the vehicle service manual for vehicle specific procedures and important data.*

## **👁 Note!**

*Before you install this product clean the vehicle.*

**1**

Put the motorcycle on a work stand so that the rear wheel barely touches the ground.

**2**

Remove the seats.

**3**

**If your vehicle is equipped with dynamic ESA:**

Disconnect the 2 connectors under the seat and free the cables to the shock absorber.

Protect the open connectors from moisture and dirt. Disconnect the position sensor not to over stretch any parts when lowering the swing arm.

**4**

Remove the silencer mounting screw and loosen the brake fluid reservoir for the rear brake.

**5**

Loosen the foot rests enough to be able to slightly raise the rear sub frame.

## **👋 Caution!**

*Make sure not to damage/scratch or over stretch any parts. While working you may need to cut off tie wraps to get access to all parts. If necessary disconnect the cable to the rectifier to avoid damaging the connection.*

**6**

Loosen, but do not remove, the upper mounting screws for the rear subframe.

Remove the lower mounting screws for the rear subframe.

**7**

Remove the shock absorber mounting bolts.

Raise the rear sub frame and remove the original shock absorber.

**8**

Install the Öhlins shock absorber in reverse order. Position the shock absorber with the preload adjuster on the right side and gas valve pointing towards the rear.

**9**

Install the upper and the lower shock absorber attachment bolts.

## **👁 Note!**

*Lower the vehicle so that the suspension is slightly compressed before you tighten s.*

# MOUNTING INSTRUCTIONS

## 10

Use the supplied M8x50 screw to install the preload adjuster on the right side silencer bracket, see figure. Tighten the screw. You may need to hold the screw not to untighten it when you tighten the M8 nut.

## 11

Install the:

- foot rests
- break fluid reservoir
- position sensor (if removed)

Tighten the rear sub frame screws.

## 12

Install the seats.

## 13

Make sure that all screws are tightened to the correct torque according to the vehicle service manual.

### **⚠ Caution!**

*Make sure that you tighten all screws to the correct torque and that nothing fouls or restricts movement of the shock absorber/front fork/steering damper when the suspension is fully compressed or extended.*

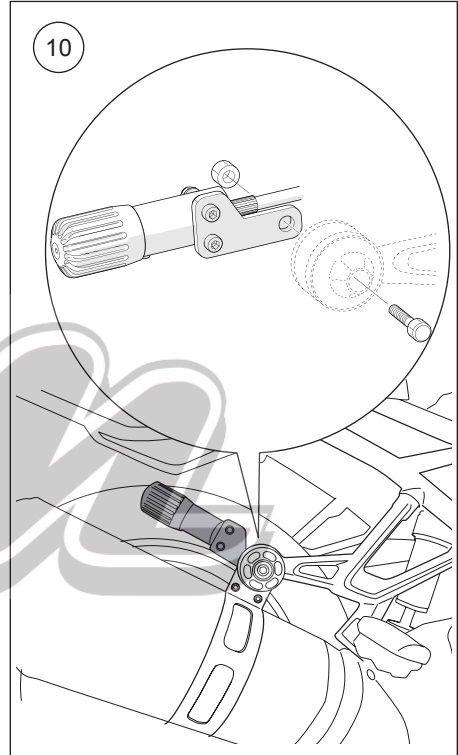

# ADJUSTMENTS

## **⚠ Warning!**

*Before you ride/drive, always make sure that the setup is according to the recommended setup data. Read about adjustments and setting up in the Öhlins Owner's Manual before you make any adjustments. Contact an Öhlins dealer if you have any questions about setting up.*

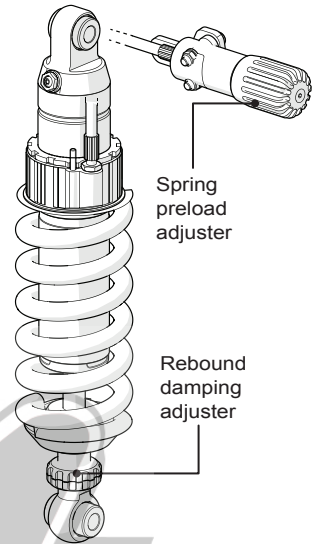

## SETUP DATA

Length	375.5	mm
Stroke	53.5	mm
Spring part no.	01096-69	
Spring rate	170	N/mm
Spring free length	190	mm
Spring preload	15	mm
Rebound	18	clicks

Recommended Free sag and Ride height		
R1-R3	24	mm
F1-F3	42	mm

Öhlins products are subject to continuous improvement and development, therefore, although these instructions include the most up-to-date information available at the time of printing, minor updates may occur.

To find the latest information contact an Öhlins distributor. Please contact Öhlins if you have any questions regarding the contents in this document.

Part no. MI\_BM511\_1  
Issued 2015-10-06

© Öhlins Racing AB. All rights reserved. Any reprinting or unauthorized use without the written permission of Öhlins Racing AB is prohibited.

Öhlins Racing AB  
Box 722  
S-194 27 Upplands Väsby, Sweden  
Phone +46 8 590 025 00  
fax +46 8 590 025 80



[www.ohlins.com](http://www.ohlins.com)