

Kit Contents		
Description	Part No	Pcs
Washer 8.4/16/1.5	00153-01	2
Tie-rod L=200	00231-01	2
Nut M8	00430-05	1
Screw 8x55	01046-27	1
Sticker "Memo notes"	01180-01	1
Sticker "Öhlins" wh/tr	01185-01	2
Sticker "Öhlins" black/tr	01185-04	2
Owner's Manual	07241-02	1
Spacer	21617-14	1

👁 Note!

Please note that there can be small differences between your product and the images in these instructions.

👁 Note!

Please note that during storage and transport, especially at high ambient temperature, some of the oil and grease used for assembly may leak and stain the packaging. This will not cause damage to the product, wipe off the excessive oil or grease with a cloth.

👁 Note!

Before you install this product, check the kit contents. If anything is missing, please contact an Öhlins dealer.

⚠ Warning!

Before you install this product, read the Öhlins Owner's manual. This product is an important part of the vehicle and the vehicle stability.

Shock absorber for BMW R 1200 RT, rear

BM 504

Mounting Instructions



MOUNTING INSTRUCTIONS

⚠ Warning!

We strongly recommend to let an Öhlins dealer install this product.

⚠ Warning!

If you work with a lifted vehicle, make sure that it is safely supported to prevent it from tipping over.

👁 Note!

When you work with this product, see the vehicle service manual for vehicle specific procedures and important data.

👁 Note!

Before you install this product clean the vehicle.

1

Put the motorcycle on a workstand so that the rear wheel barely touches the ground.

2

Remove the silencer by loosening the clamp and the rear attachment.

3

Loosen and remove the seat. Remove the carrier rack and all side fairings, first the front then the rear ones.

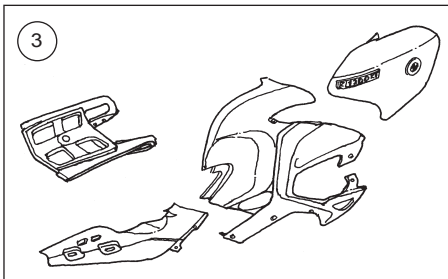

👁 Note!

The screws holding the fairings are of different lengths. Make sure to reinsert them to the correct position.

4

If the motorcycle is equipped with ESA the electrical plugs must be disconnected from the shock absorber.

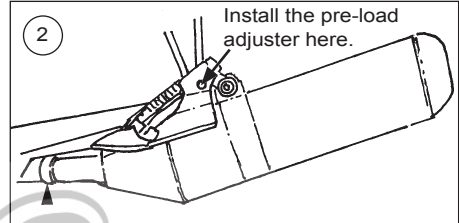

5

First loosen the lower shock absorber bracket, then the upper. Remove the original shock absorber.

6

Install the Öhlins shock absorber, first attach the upper attachment, then the lower one.

MOUNTING INSTRUCTIONS

7

Install the hydraulic pre-load adjuster at the foot rest bracket on the left side according to the figure.

Use the parts provided in the kit:

- M8x55 screw
- 2 washers
- spacer
- lock nut

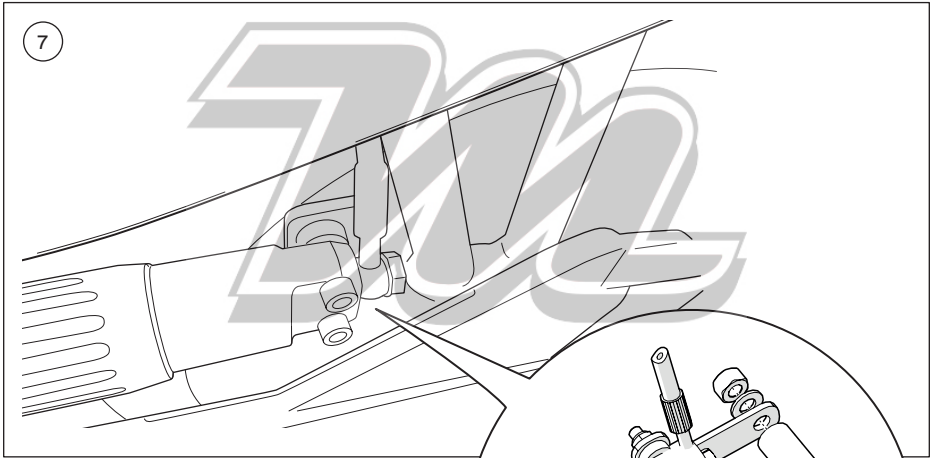

8

Make sure that the hose runs in soft bends and attach it with the tie-raps (00231-01) provided.

9

Install the fairings, the carrier and the seat.

Note!

Lower the vehicle so that the suspension is slightly compressed before tightening the screws.

Caution!

Ensure that all screws are tightened to the correct torque and that nothing fouls or restricts movement of the shock absorber/front fork/steering damper when the suspension is fully compressed or extended.

ADJUSTMENTS

⚠ Warning!

Before you ride/drive, always make sure that the setup is according to the recommended setup data. Read about adjustments and setting up in the Öhlins Owner's Manual before you make any adjustments. Contact an Öhlins dealer if you have any questions about setting up.

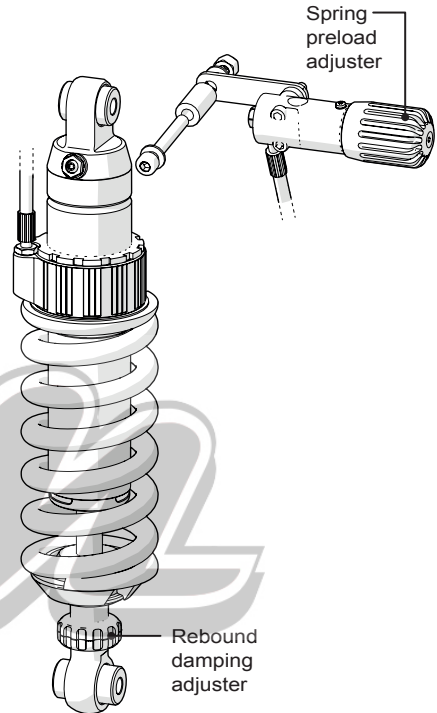

SETUP DATA

Length	375	mm
Stroke	53	mm
Spring (part no.)	01096-69	
Spring rate	170	N/mm
Spring free length	190	mm
Spring preload	17	mm
Rebound	18	clicks

Öhlins products are subject to continuous improvement and development, therefore, although these instructions include the most up-to-date information available at the time of printing, minor updates may occur.

To find the latest information contact an Öhlins distributor. Please contact Öhlins if you have any questions regarding the contents in this document.

Part no. MI_BM504_1
Issued 2015-01-09

© Öhlins Racing AB. All rights reserved. Any reprinting or unauthorized use without the written permission of Öhlins Racing AB is prohibited.

Öhlins Racing AB
Box 722
S-194 27 Upplands Väsby, Sweden
Phone +46 8 590 025 00
fax +46 8 590 025 80



www.ohlins.com