

Adjustments

⚠ Warning!

Before riding, always make sure that the basic settings made by Öhlins are according to recommended Set-up Data. Read about adjustments and setting up in the Öhlins Owner's Manual before you make any adjustments. Contact an Öhlins dealer if you have any questions about setting up the shock absorber.

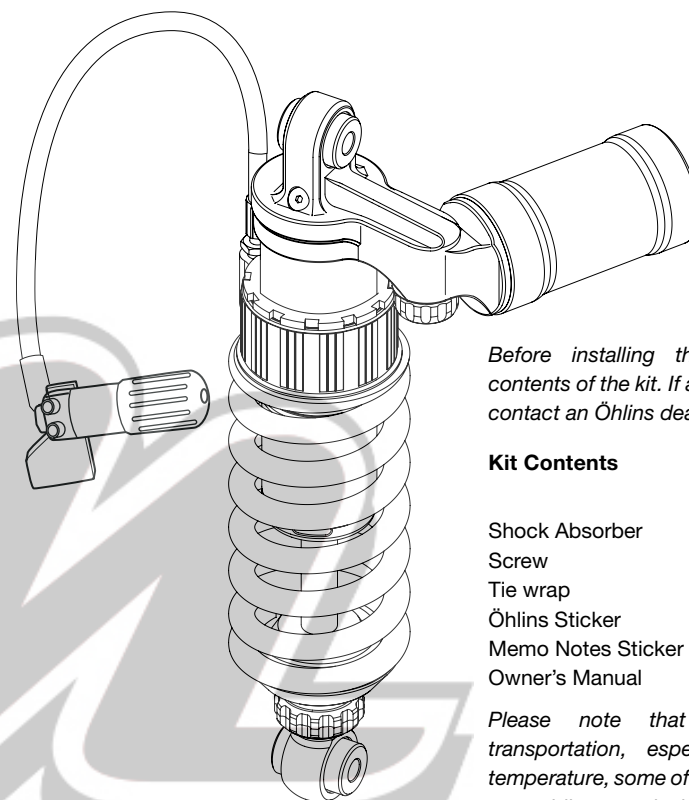
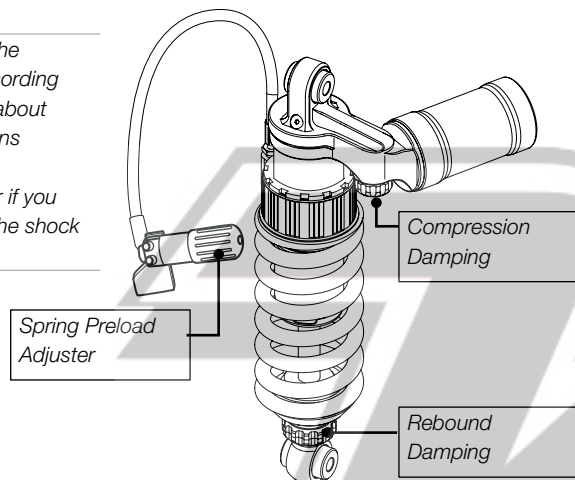

Before installing this product, check the contents of the kit. If anything is missing, please contact an Öhlins dealer.

Kit Contents

	Part No.	Pcs.
Shock Absorber	BM502	1
Screw	01046-21	1
Tie wrap	00231-01	2
Öhlins Sticker	00192-01	2
Memo Notes Sticker	01180-01	1
Owner's Manual	07241-02	1

Please note that during storage and transportation, especially at high ambient temperature, some of the oil and grease used for assembling may leak and stain the packaging. This is in no way detrimental to the product, wipe off the excessive oil/grease with a cloth.

⚠ Warning!

Before installing this product, read the Öhlins Owner's Manual. The shock absorber is an important part of your vehicle and will affect the stability.

Set-up Data

Recommended set-up

Rebound	18 clicks
Compression	12 clicks
Spring Preload	17 mm

Shock absorber data

Length	334 mm
Stroke	78

Recommended Sag and Ride Height

Free Sag (R1-R2)	13 mm
Ride Height (R1-R3)	28 mm

👁 Read about Free Sag and Ride height in the Öhlins Owner's Manual.

👁 Öhlins products are subject to continuous improvement and development, therefore, although these instructions include the most up-to-date information available at the time of printing, minor updates may occur.

To find the latest information contact your Öhlins distributor. Please consult your Öhlins dealer if you have any questions regarding the contents in this document.

Part no. BM446_0
Issued 2009-06-24



© Öhlins Racing AB. All rights reserved. Any reprinting or unauthorized use without the written permission of Öhlins Racing AB is prohibited.

Öhlins Racing AB
Box 722
S-194 27 Upplands Väsby, Sweden
Phone +46 8 590 025 00
fax +46 8 590 025 80



www.ohlins.com

Shock Absorber for BMW K 1200/1300 R - Rear **BM 502**

Mounting Instructions



⚠ Warning!

It is advisable to have an Öhlins dealer install the shock absorber.

When installing, read the Vehicle Service Manual.

1

Put the motorcycle on a workstand so that the rear wheel barely touches the ground. The swing arm must be free so that the suspension is unloaded.

⚠ Warning!

Make sure the vehicle is securely supported so that it will not tip.

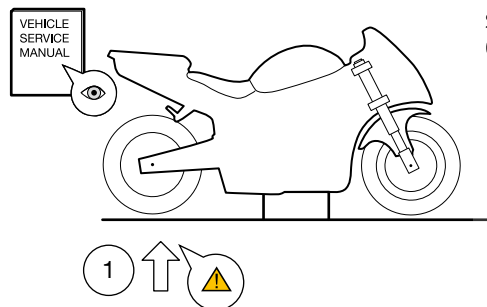

2

Remove the seat.

3

Loosen the rear attachment screws of the front side fairings.

4

Loosen the rear tank attachment.

5

Loosen the upper attachment screws of the rear sub frame, do not remove them. Remove the lower attachment screws.

6

Remove the left side foot rest bracket.

7

Loosen the heat shield and the clamp of the exhaust pipe. Loosen the rear screw of the silencer bracket and remove the silencer.

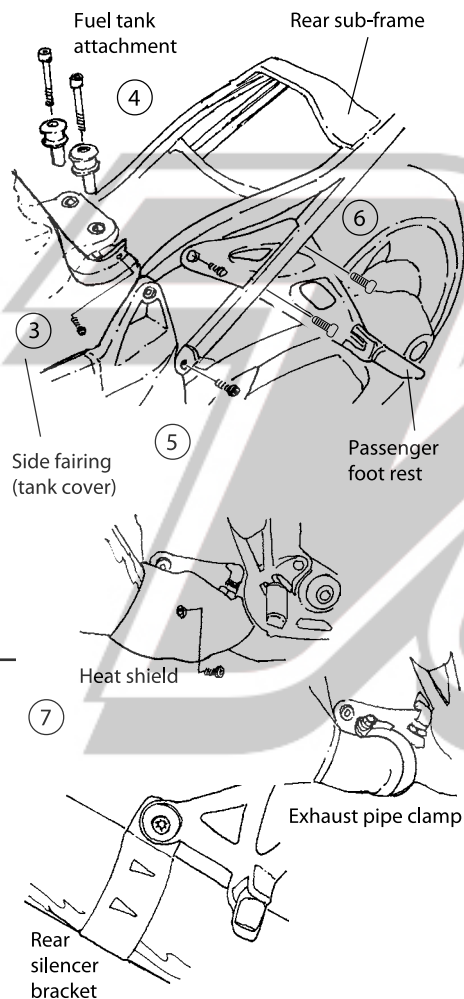

8

Loosen the oil reservoir attachment screw located at the left and right foot rest brackets.

9

Remove the bolts at the front part of the rear sub frame.

10

Loosen the two bolts of the drive shaft upper control arm and remove it.

11

Put the cables on the left side of the upper side of the reservoir, so that they follow the sub frame when lifted up.

12

Raise the rear sub frame and put a strap or similar to the sub frame and the handlebar to keep it in an upright position.

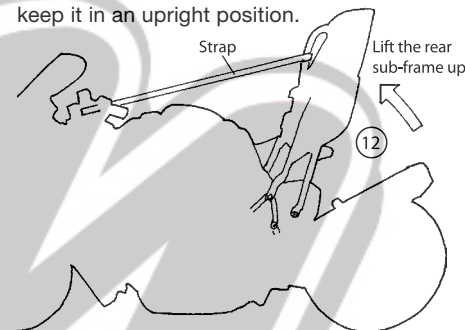

13

If the motorcycle is equipped with ESA the electrical connectors must be disconnected from the harness with two connectors below the lower cover at the 12 volt connection on the left side, and one connector on the left side in front of the oil reservoir.

14

First, loosen the lower shock absorber bracket, then the upper. Remove the original shock absorber from the left side.

👁 Note!

Before installing the Öhlins shock absorber clean the vehicle thoroughly.

15

Install the Öhlins shock absorber like the original unit.

👉 Caution!

The oil reservoir must be slightly moved to make room for the shock absorber. Be careful not to damage the reservoir connections.

16

Lower and reinstall the rear sub frame. Reinstall the screws and tighten.

👁 Note!

Lower the motorcycle so that the shock absorber is slightly compressed, before tightening the screws.

17

Reinstall the hose to the oil reservoir and put the cables back in original position.

18

Reinstall the left side foot rest bracket and the attachment screws to the oil reservoir.

19

Reinstall the silencer, but do not fixate the rear bracket yet.

20

Install the new preload adjuster to the silencer bracket on the right side of the motorcycle. Use the screw provided in this kit. The preload bracket should be installed between the foot rest bracket and the silencer bracket. Fasten the silencer bracket.

21

Make sure that the hose runs in soft turns and fasten it with tie wraps.

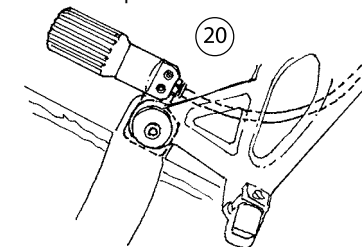

22

Reinstall the screws to the rear fuel tank bracket.

23

Reinstall the side cover attachment screws and the seat.

👉 Caution!

Make sure that all screws are tightened to the correct torque and that nothing fouls or restricts movement of the shock absorber when the suspension is fully compressed or extended.